

# FLUKE®

## 321 and 322 Clamp Meter Instruction Card

### ⚠ Warning

- Read the 321, 322 Clamp Meter Safety Sheet before using this meter.
- Lisez la fiche de sécurité 321, 322 Clamp Meter Safety Sheet avant d'utiliser cet appareil.
- Prima di usare questo strumento, leggere il documento 321, 322 Clamp Meter Safety Sheet.
- Vor der Verwendung des Meßgeräts die Sicherheitsinformationen zum 321, 322, Clamp Meter lesen
- Lea la hoja de instrucciones de seguridad "321, 322 Clamp Meter Safety Sheet" antes de utilizar este medidor.
- Leia "321, 322 Clamp Meter Safety Sheet" antesde usar este medidor.
- Lees het 321, 322 Clamp Meter Safety Sheet voordat u deze meter gebruikt
- Les 321, 322 Clamp Meter Safety Sheet før måleinstrumentet tas i bruk.
- Man skal læse "321, 322 Clamp Meter Safety Sheet" inden man tager instrumentet i brug.
- Lue 321, 322 Clamp Meter Safety Sheet ennen tämän laitteen käyttöä.
- Läs säkerhetsdatabladet "321, 322 Clamp Meter Safety Sheet" innan du använder detta instrument.
- 本器を使用する前に、321, 322 Clamp Meter Safety Sheet (321, 322 クランプ・メーターの安全シート)をお読みください。
- 이 계기를 사용하기 전에 321, 322 Clamp Meter Safety Sheet 를 읽으십시오.
- 使用本儀表前請先閱讀 321, 322 Clamp Meter Safety Sheet 。
- 使用本儀表前請先閱讀 321, 322 Clamp Meter Safety Sheet
- โปรดอ่านแผ่นข้อมูลเพื่อความปลอดภัย 321, 322 Clamp Meter Safety Sheet ก่อนที่ท่านจะใช้มิเตอร์นี้

### On/Off

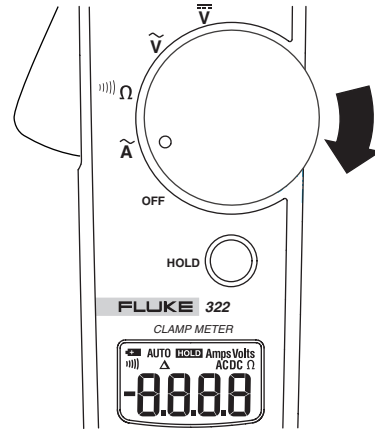

### Automatic Off

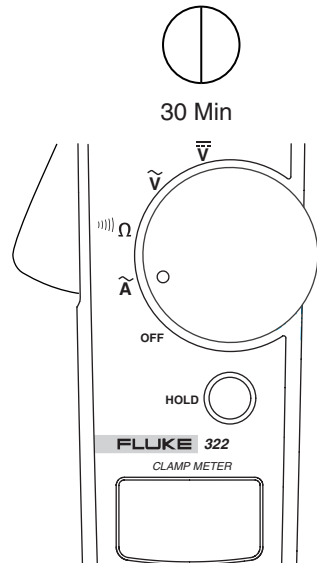

### ~ A

Fluke 321 0 - 400.0 A  
Fluke 322 0 - 40.00 A, 40.0 - 400.0 A

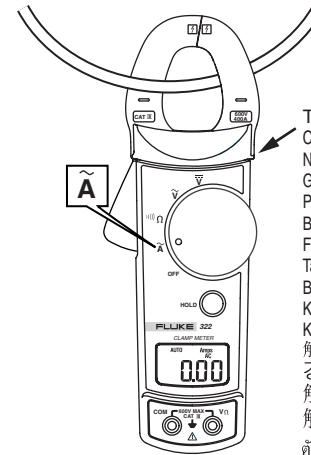

Tactile Barrier  
Collerette de protection (Fem.)  
Nervatura di sicurezza  
Griffschutz  
Protección dactilar  
Barreira tátil  
Folebarriere  
Tastbare barrière  
Beröringsgrensen  
Kosketuseste  
Känselbarriär  
触知バリアー  
경계선  
觸摸隔层。  
觸覺屏障  
ตัวกั้นบอกระยะปลอดภัย

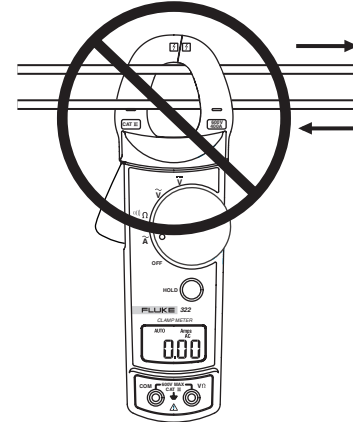

### Currents Cancel

Les courants s'annulent, Le correnti si cancellano,  
Ströme abbrechen, Se cancelan las corrientes,  
Cancelamento de correntes, Stromen compenseren  
elkaar, Strømutjevning, Strømstyrkeannullering  
Strømstyrker udbalancerer, Virta pois, Avbryt ström  
電流のキャンセル, 전류 상쇄, 電流互相取消,  
電流互相取消, ยกเลิกกระแสไฟฟ้า

## Specifications

* @ 23 °C ± 5 °C, 0 - 90% RH		321	322
~ A	Range	0 - 400.0 A	0 - 40.00 A 40.0 - 400.0 A
	Accuracy	50 - 60 Hz 60 Hz - 400 Hz	1.8% ± 5 counts 3.0% ± 5 counts
	AC Response	Avg	
~ V	Range	0 - 400.0, 400 - 600 V	
	Accuracy	50 - 400 Hz 1.2% ± 5 counts	
~ V	Range	-	0 - 400.0, 400 - 600 V
	Accuracy	1% ± 5 counts	
Ω	Range	0 - 400.0 Ω	
	Accuracy	1.0% ± 5 counts	
Continuity	)))	≤ 30 Ω	
Jaw Opening	1 inch or 26 mm		
IP Rating	40		
Storage Temperature	-30 °C to 60 °C		
Operating Temperature	-10 °C to 50 °C		
Altitude	2000 m		
EMC - EN61326			
<b>CAT III 600V, pollution degree II:</b> CAT III equipment is designed to protect against transients in equipment in fixed - equipment installations, such as distribution panels, feeders and short branch circuits, and lighting systems in large buildings.			
* < 18 °C, > 28 °C add 0.1 x (specified accuracy)/ °C.			

## Continuity

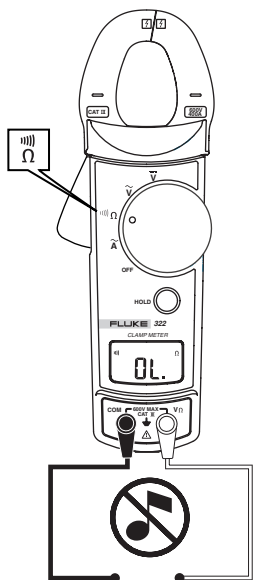
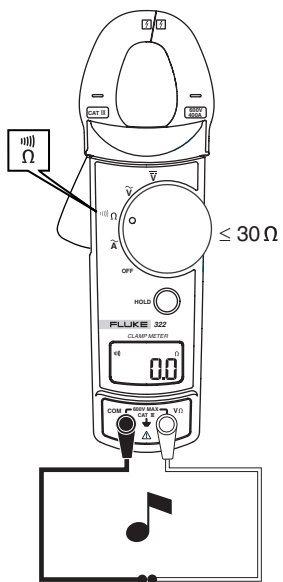

## Hold

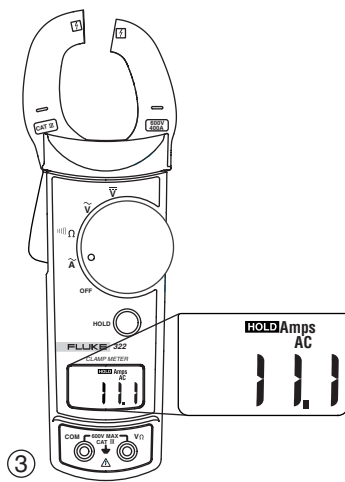
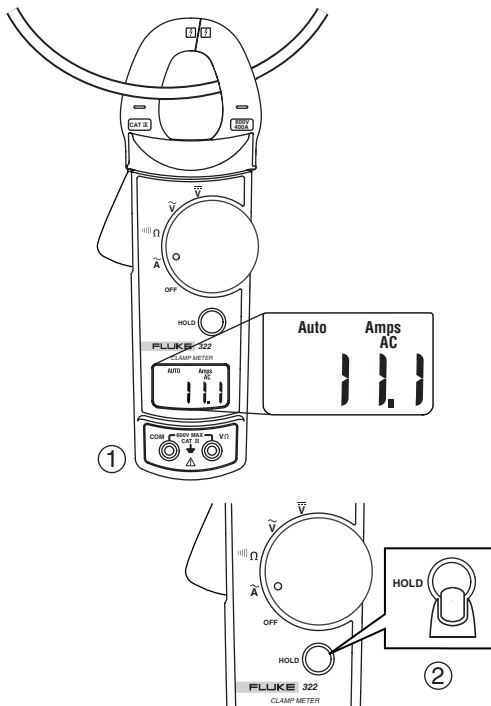

## Battery Replacement

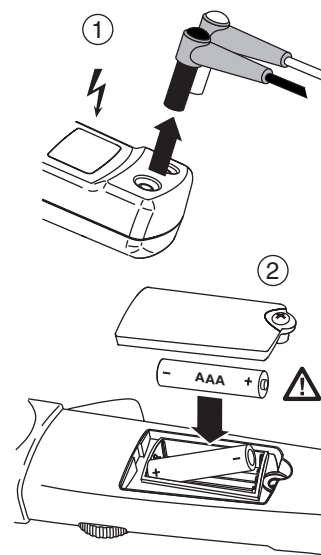

V, Ω  
 0 - 600 V dc 322  
 0 - 600 V ac  
 0 - 400.0 Ω

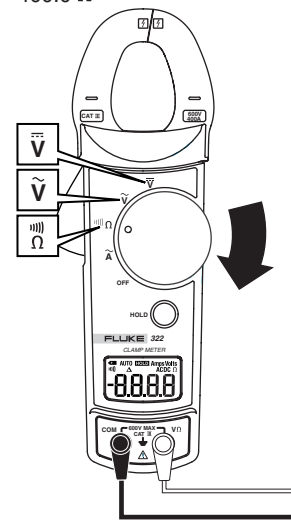

## Cleaning

- Wipe the case with a damp cloth and mild detergent. Do not use abrasives or solvents.
- Nettoyage : essuyer l'étui à l'aide d'un chiffon humide et d'un détergent non-abrasif. Ne pas utiliser d'abrasifs ou de solvants.
- Pulizia : pulire l'involucro con un panno umido e un detergente neutro. Non usare né abrasivi né solventi.
- Limpieza: Limpie la caja con un paño húmedo y un detergente suave. No utilice abrasivos ni solventes.
- Reinigung: Das Gehäuse mit einem feuchten Lappen und mildem Reinigungsmittel abwischen. Keine Scheuer- oder Lösungsmittel verwenden.
- Limpeza: Para limpar a parte externa, use um pano úmido com detergente neutro. Não use produtos abrasivos nem solventes.
- Reinigen: Veeg de behuizing af met een vochtige doek en niet-agressief detergens. Gebruik geen schuurmiddelen of oplosmiddelen.
- Rengjøring: Tørk av huset med en fuktig klut og mildt vaskemiddel. Bruk ikke skuremidler eller løsemidler.
- Rengøring: Tør instrumenthuset af udenpå med en fugtig klud og mildt sæbevand. Der må ikke benyttes skure- og opløsningsmidler.
- Puhdistaminen: Pyyhi kotelo kostealla kankaalla ja miedolla pesuaineella. Älä käytä hankausaineita tai liuottimia.
- Rengöring: Torka av kåpan med en fuktad trasa och ett mildt rengöringsmedel. Använd inte nötande rengöringsmedel eller lösningsmedel.
- 清洁: 请用微湿的布及中性的清洁剂擦拭盒子。请勿使用腐蚀性或溶剂。
- 清潔: 使用微濕的布和輕微的清潔劑擦拭盒子。不可使用具有侵蝕或溶劑。
- クリーニング: ケースは、水で軽く湿らせた布と弱中性洗剤を使用して拭くようにします。研磨剤や溶剤は使用しないでください。
- 청소: 케이스는 젖은 천과 중성 세제로 닦으십시오. 용제나 연마제는 사용하지 마십시오.
- การทำความสะอาด  
 เช็ดทำความสะอาดโดยลอกด้วยผ้าที่เปียกพอหมาดๆ  
 หรือน้ำยาทำความสะอาดอ่อนอย่างอ่อน  
 อย่างคด้วยความแรงหรือใช้สารเคมี