

*Model 3301B*

# Active Rod & Field Antenna

## MANUAL



ETS-Lindgren L.P. reserves the right to make changes to any products herein to improve functioning, design, or for any other reason. Nothing contained herein shall constitute ETS-Lindgren L.P. assuming any liability whatsoever arising out of the application or use of any product or circuit described herein. ETS-Lindgren L.P. does not convey any license under its patent rights or the rights of others.

© Copyright 2003 by ETS-Lindgren L.P. All Rights Reserved.  
No part of this document may be copied by any means  
without written permission from ETS-Lindgren L.P.

**E-MAIL & INTERNET**

Support@ets-lindgren.com  
<http://www.ets-lindgren.com>

**USA**

1301 Arrow Point Dr., Cedar Park, TX 78613  
P.O. Box 80589, Austin, TX 78708-0589  
Phone 512.531.6400  
Fax 512.531.6500

**JAPAN**

4-2-6, Kohinata  
Bunkyo-ku  
Tokyo 112-0006  
JAPAN  
Phone + 81 3 3813 7100  
Fax + 81 3 3813 8068

**FINLAND**

Euroshield OY  
Mekaanikontie 1  
27510, Eura, Finland  
Phone + 358.2.838.3300  
Fax + 358.2.865.1233

**CHINA**

1917-1918 Xue Zhixuan Building  
No 16 Xue Qing Road  
Haidian District  
Beijing Postcode: 100083  
CHINA  
Phone + 86 010 82755304  
Fax + 86 010 82755307

# Table of Contents

<b>INTRODUCTION</b> .....	<b>1</b>
<b>STANDARD CONFIGURATION</b> .....	<b>2</b>
<b>OPTIONS</b> .....	<b>2</b>
<b>SPECIFICATIONS</b> .....	<b>3</b>
OPERATIONAL SPECIFICATIONS.....	3
ELECTRICAL SPECIFICATIONS.....	5
MECHANICAL SPECIFICATIONS.....	6
<b>PRINCIPLES OF OPERATION</b> .....	<b>7</b>
DESCRIPTION.....	7
FRONT PANEL.....	7
INTERNAL OPTIONS.....	8
<b>POWER CIRCUITRY</b> .....	<b>11</b>
VOLTAGE-SELECTABLE BATTERY CHARGER.....	11
BATTERY LOW INDICATOR.....	13
FUSES.....	13
<b>SETUP AND USE</b> .....	<b>14</b>
SETUP.....	14
HIGH SENSITIVITY READINGS.....	15
<b>THEORY OF OPERATION</b> .....	<b>17</b>
THE ROD.....	17
THE PRE-AMPLIFIER.....	19
<b>THE ANTENNA FACTOR</b> .....	<b>21</b>
<b>ANTENNA IMPULSE RESPONSE</b> .....	<b>22</b>
IMPULSE CHARACTERISTICS.....	22
PULSE DESENSITIZATION.....	24
PULSE CHARGING.....	25
<b>CALIBRATION PROCEDURE</b> .....	<b>26</b>
<b>3301B PARTS LIST</b> .....	<b>27</b>
ACCESSORIES AVAILABLE.....	27
<b>MAINTENANCE</b> .....	<b>27</b>
<b>WARRANTY STATEMENT</b> .....	<b>28</b>
<b>EUROPEAN COMMUNITY DECLARATION OF CONFORMITY</b> .....	<b>29</b>
<b>DATA AND ILLUSTRATIONS</b> .....	<b>30</b>



---

# INTRODUCTION

---

The ETS-Lindgren Model 3301B is a broadband, high sensitivity Electric-Field Receiving Antenna. The unit is composed of a monopole rod antenna with a counterpoise and a broadband, high impedance pre-amplifier. The unit is designed to provide reception of an electric field in a signal band without tuning or band switching from 30 Hz to 50 MHz. The 3 dB roll off points for the antenna factor are at 170 Hz and 30 MHz. Between 250 Hz and 20 MHz, the antenna factor is flat within +/- 1 dB. Despite the roll of the unit's antenna factor, the usable range is 30 Hz to 50 MHz.

The 3301B has been designed for maximum sensitivity and dynamic range. The 3301B is capable of sensing fields of 2 dBuV/m at 1 MHz with a 1 kHz bandwidth. However, it will not saturate below a field strength of 0.7 V/m. Hence, the unit boasts an extremely wide dynamic range of 115 dB nominal at mid-band. In addition, at 10 and 30 dB (+/-10%) internal attenuators are provided. With the attenuators the unit is usable in fields of up to 22 V/m. Thus the dynamic range of the unit is expanded to 145 dB. A saturation indicator is provided to alert the user to the need for using the internal attenuators.

The Model 3301B has been designed to provide the user with an extremely versatile measurement tool. Its flat antenna factor, extreme sensitivity and ultra-wide dynamic range make it a state of the art sensing instrument.

---

# STANDARD CONFIGURATION

---

- Adjustable monopole element
- Antenna base with built-in preamplifier and an isolated female BNC connector
- Counterpoise (60 cm)
- Base drilled to accept EMCO or other tripod mounts with standard ¼" x 20 threads
- Batteries and battery charger
- Individually calibrated per ECSM or IEE Std. 291. Actual individual calibration factors and signed Certificate of Calibration Conformance included in Manual.

---

## OPTIONS

---

**Remote Monitor:** A 10 meter (32.8 ft) fiber optic Remote Monitor Option for remote display of power-on and saturation indicators.

**Tripods:** ETS-Lindgren offers two nonmetallic, non-reflective tripods for use at both indoor and outdoor EMC test sites.

The Model 4-TR, constructed of linen phenolic and delrin, is designed with an adjustable center post for precise height adjustments. Maximum height for the 4-TR is 2.0 m (80.0 in), while minimum height is 94 cm (37.0 in). This tripod can support up to an 11.8 kg (26.0 lb) load.

The 7-TR tripod has several different configurations, including options for manual or pneumatic polarization. This tripod provides increased stability for physically large antennas. Its unique design allows for quick assembly/disassembly and convenient storage. Quick height adjustment and locking wheels provide ease of use during testing. This tripod can support a 13.5 kg (30 lb) load. For the 7-TR series, maximum height is 2.17 m (85.8 in), with a minimum height of .8 m (31.8 in). The 7-TR is constructed of PVC and fiberglass components.

# SPECIFICATIONS

---

## OPERATIONAL SPECIFICATIONS

---

<b>Frequency Range:</b>	30 Hz to 50 MHz (maximum usable bandwidth)
<b>Low Frequency Roll Off:</b>	The low frequency roll off is switch selectable to be 3dB down at 22 kHz, 1.9 kHz or 170 Hz
<b>High Frequency Roll Off:</b>	Antenna factor is 3 dB down at 30 MHz.
<b>Antenna Factor:</b>	See attached graphs. The calibration graphs were taken with the unit in the Low Gain setting. Unless otherwise noted, the low frequency roll off is set at the 170 Hz 3dB roll off point.
<b>Saturation Level:</b>	0.7 V/m narrowband w/o attenuation and at the low gain setting. 22 V/m with 30 dB of internal attenuation selected. 63 dBuV/m/MHz broadband saturation level.
<b>Minimum Discernible Signal:</b>	See attached graphs. For best sensitivity the unit should be in the Low Gain setting with all Internal Attenuation off.
<b>Dynamic Range:</b>	115 dB at mid-band (1 MHz). 145 dB with the use of the internal attenuators.
<b>Saturation Indicator Impulse Response:</b>	The saturation indicator will properly indicate saturation for pulsed signals which fall within the following boundaries: <ol style="list-style-type: none"> <li>1. The product of the pulse width to pulse repetition rate must be greater than .003.</li> <li>2. The pulse repetition rate must be less than value listed for the applicable duty cycle. See table 1.</li> </ol>

Duty Cycle	Maximum PRF
10	19.7 MHz
20	14.0 MHz
30	9.2 MHz
40	5.6 MHz
50	420.0 kHz
60	130.0 kHz
70	87.0 kHz
80	57.0 kHz
90	30.0 kHz

**Table 1. Acceptable Pulse Repetition Rates**



---

## ELECTRICAL SPECIFICATIONS

---

<b>Input Impedance:</b>	The input impedance determines the low frequency roll off point. Depending on the low frequency roll off selected, the input impedance is >20 Megohms, 1 Megohm or 100 Kiloohm.
<b>Output Impedance:</b>	50 ohm (nominal)
<b>Saturation Impedance:</b>	A red LED on the front panel will be illuminated when the unit begins to saturate or clip. The saturation indicator will indicate accurately for any gain and attenuator setting.
<b>Battery Low Indicator:</b>	The power light on the front panel also serves as a Battery Low Indicator. If the green light does not come on when the power switch is engaged, then the battery requires recharging. It is recommended that the 3301B be connected to the battery charger at all times when it is not in use.
<b>Batteries:</b>	The unit is supplied with two 6 volt sealed lead-acid batteries. The batteries will operate for approximately 10 hours between charges.
<b>Battery Charger:</b>	115/230 VAC 50/60 Hz switch selectable, IEC input, two-stage battery charger with fast and trickle charge modes.
<b>Fuses:</b>	Type 3AG size .5 Amp, fast acting Or 5x20mm, .5 Amp, fast acting Internally mounted.

---

## MECHANICAL SPECIFICATIONS

---

<b>Size:</b>	7.38" x 4.62" x 3.5"
<b>Weight:</b>	Approximately 7 lbs.
<b>Tripod Mounting:</b>	A 1/4-20 hole is provided on the base for tripod mounting. NOTE: This is not intended as a grounding point.
<b>Counterpoise Mounting:</b>	Four 6-32 holes are provided in the two metal mounting bars on the top of the unit.
<b>Antenna Element:</b>	The antenna element may be set up to 41".

---

# PRINCIPLES OF OPERATION

---

---

## DESCRIPTION

---

The ETS-Lindgren 3301B Electric Field Receiving Antenna is composed of three (3) principal sections: a sensing rod, a ground plane or counterpoise and a broadband, high input impedance pre-amplifier.

The rod and counterpoise function together as an electrically short antenna over ground plane. The pre-amplifier provides impedance transformation from the extremely high impedance at the base of the rod to the 50 ohms required by most receiving systems and provides power gain to allow the sensing of very low level signals.

---

## FRONT PANEL

---

The front panel of the 3301B presents the user with:

1. Power Switch
2. Gain Switch
3. Saturation Indicator Light
4. Battery Low/Power on Indicator Light
5. BNC Output Port
6. Battery Charging Port

The Power Switch on the unit is located on the lower right side of the front panel. Activating the power switch will turn on the green Battery Low/Power On Indicator.

The Battery Low/Power On Indicator is controlled by a voltage monitor circuit. Should the green indicator not turn on, or if it should turn off during use, this indicates that the battery requires charging.

In the middle left of the unit is the Gain Switch. This switch increases the voltage output of the gain stage in the amplifier by 10 dB. However, best sensitivity is achieved in the Low Gain setting.

The gain option provides additional output power for test situations which require additional output.

A Saturation Indicator Light is located above the power indicator. Readings should not be taken when the unit indicates it is in saturation. Should this occur input to the unit should be reduced by placing the unit in the low gain mode or by switching in internal attenuation. Impulsive type signals present a particular problem in that they may put the unit into a non-linear region without triggering the saturation circuit. When dealing with impulsive type signals the 63 dBu V/m/MHz should be strictly observed. Should a signal exceed this limit the internal attenuation should be applied. The limiting factor on handling impulsive signals is the unit output capability. Hence, once the internal attenuators are engaged, most higher impulsive signals may be measured. For example, with the 30 dB attenuator engaged, a 93 dBuV/m/MHz may be measured.

A battery charging port is provided for easy recharging of the sealed lead-acid batteries internal to the unit. To charge the unit, simply turn off the power switch and plug in the battery charger provided. It is important that the power switch be turned off as the charging circuit will not charge the batteries with the unit turned on.

## INTERNAL OPTIONS

---

Internal to the unit is a four (4) switch bank of slide switches. These switches control the internal attenuation and the low frequency roll off.

Access to the switch bank is gained by holding the unit upside down and removing the bottom cover. With the unit upside down and the front panel to the left, the top switch, closest to the fuse holder, adds 10 dB of internal attenuation. The next switch down adds 30 dB of attenuation. The third switch sets the low frequency roll off of 3dB down at 1.9 kHz. The fourth switch sets the low frequency roll off of 3 dB down at 22 kHz.

**CAUTION** The antenna rod terminal is directly connected to the high impedance gate of a field effect transistor. Do not lift the antenna by the rod or touch it before properly grounding out to the unit case. Accumulated static charge on test personnel may damage the FET. If the antenna is used in a location where static discharges are likely to be prevalent, attach a grounding clip between the chassis and the antenna rod while the antenna is being set up to prevent damage to the amplifier circuitry.

*Note: The diagram below reflects the sequence of functions as they are connected on the board.*

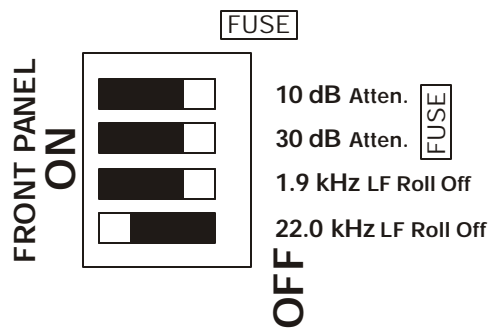

10 dB (+/- 10%) Input Attenuator  
 30 dB (+/- 10%) Input Attenuator  
 1.9 kHz Low Frequency Roll Off  
 22.0 kHz Low Frequency Roll Off

Moving any switch to the extreme left, toward the center of the unit activates the indicated function. Moving the switch to the extreme right, toward the side of the unit, deactivates that function. The most commonly used configuration will have the 22 kHz roll off switch on and all other options off.

## FACTORY SETTINGS

The unit comes configured from the factory with the 22.0 kHz Low Frequency Roll Off, set ON. All other switches are off.

It is anticipated that the unit will normally be used with one of the roll off switches ON. Due to the abundance of low frequency ambient noise, in most settings using the full bandwidth of the unit will make it very susceptible to saturation. However, when extremely low frequency measurements are required, the unit is capable of providing these measurements.

If both roll off switches, are simultaneously set in the ON position, the low frequency, 3 dB roll off point will be approximately 23 kHz.

## PROPER SELECTION OF INTERNAL ATTENUATION

When dealing with CW type signals, no attenuation is needed to measure field strengths below 0.7 V/m. At approximately this level, the saturation indicator light will come on. This indicates a need to switch ON the 10 dB attenuator.

When the 10 dB attenuator is switched ON the 3301B can measure field strengths up to 2.2 V/m without saturating. The unit retains 115 dB of dynamic range, but the maximum reading before saturation is raised by 10 dB while the minimum discernible signal is also raised by 10 dB. At 2.2 V/m, with the 10 dB attenuator active, the saturation indicator light will again come on. This indicates a need to switch the 30 dB attenuator ON in place of the 10 dB attenuator.

The 30 dB internal attenuator will allow the unit to maintain its calibration while measuring field strengths up to 22 V/m. Again, the unit retains 115 dB of dynamic range. Both the maximum reading before saturation and the minimum discernible signal are raised 30 dB above their 0 dB attenuation values.

When using either of the attenuators, be sure to add the attenuation to the antenna factor for accurate readings. Also, note that if both attenuator switches are used, the resulting attenuation is approximately 31 dB and not 30 dB.

Please be aware that it is unwise to use attenuation to measure very low field strengths. When the field strength falls below the minimum discernible signal, inaccurate field strength measurements will result.

Both of the internal attenuators have a 10% tolerance, so they should be calibrated before being used in critical applications.

One final **WARNING** about the internal 30 dB attenuator is in order. With the 30 dB attenuator active, the unit resonates at 30 MHz. Therefore, the unit should not be used above 15 MHz with the 30 dB attenuator active.

The usefulness of the internal attenuators for impulse response testing is discussed in “Antenna Impulse Response.”

## POWER CIRCUITRY

---

The Model 3301B is powered by two (2) – six (6) VDC sealed lead-acid batteries. A battery charger is supplied with the unit. The battery charging port of the front of the unit allows for easy recharging of the unit. Two (2) internal fuses protect the unit from unintentional shorting.

## VOLTAGE-SELECTABLE BATTERY CHARGER

---

### OPERATION

The EMCO brand Voltage-Selectable Battery Charger is solely intended for charging the sealed lead-acid batteries found in EMCO products. The battery charger is a means of providing the necessary charge voltage and current from either a 115 or 230 VAC 50/60 Hz source.

**NOTE:** It is necessary to select the proper input voltage **PRIOR** to connecting the battery charger to the power mains. The voltage select switch is located adjacent to the power input receptacle.

To maintain safety requirements, use the CSA certified power cord provided. If it is necessary to provide other means of attaching the battery charger to the power mains it is required that a type HD 21 (PVC cord) or type HD22 (rubber cord) with a nominal cross section of 0.75 mm are to be used.

The battery charger provides both fast and trickle charge operation. Switching from one charge mode to the other is provided automatically by the charger. The front panel indicator marked “Fast Charge” lights when the battery charger is in the fast charge mode. When the “Power On “ light is illuminated and the “Fast Charge” light is extinguished, the battery charger is in the trickle charge mode.

The antenna should be connected to the battery charger in “Trickle Charge” mode when not in use. Charging time is approximately eight hours when batteries are completely discharged. Note: The antenna is not designed to operate using the Battery Charger as a power source. Batteries should provide power to the amplifier for approximately 16 hours before recharging is required.

The battery charger is protected against overcurrent by a 200 mA 250 VAC time-delay fuse. If it becomes necessary to replace the fuse, use a fuse of the same type and rating to maintain safe operations. The fuse is accessible by removing the two (2) “Phillips” head screws on the underside of the unit. Always remove main power before opening the housing. The output of the battery charger is protected against overcurrent conditions by use of “fold-back” circuitry.

## SPECIFICATIONS

<b>Input voltage:</b>	115/230 VAC selectable
<b>Input frequency:</b>	50/60 Hz
<b>Input power:</b>	20 VA max
<b>Protection class:</b>	Class II double insulated
<b>Input fuse rating:</b>	200 mA time-delay type 5x20 mm
<b>Input power connection :</b>	IEC-320 power inlet
<b>Output voltage:</b>	12 VDC (13.5-15 VDC)
<b>Output current:</b>	350 mA



**Safety approvals:** TUV, CSA

## BATTERY LOW INDICATOR

---

A Battery Low Indicator/Power On Indicator is located on the front of the unit. Should this LED not light when the power switch is engaged, the batteries should be recharged.

## FUSES

---

There are two fuses, one for each battery, located inside the Model 3301B. It is necessary to remove the bottom panel of the unit to replace fuses. Disconnect the power cord and charger before opening the unit. When fuse replacement is necessary, using a Phillips head screwdriver carefully remove the screws around the edge of the bottom panel and lift the panel off of the unit. Locate the two fuses in their holders mounted on the circuit board. The fuse holders provided will accommodate either Type AC Size 0.5 AMP Fast Acting or 5x20mm fuses. After the new fuses are installed, replace the bottom panel of the unit and reinstall the screws.

---

# SETUP AND USE

---

The 3301B has been designed for ease of use. The unit has been designed for five (5) accurate reading types in a variety of test environments. However, precision measurements require an understanding of the test parameters which will adversely affect test results. No single test instrument can insure accurate results. For best results, the user should become thoroughly familiar with both the practical and theoretical operating parameters for this unit.

---

## SETUP

---

Before beginning the setup procedure, ensure that the technician is completely grounded using an ESD wrist strap at an ESD protective workstation for protection of the antenna FET. Ensure antenna power is OFF.

The 3301B is quite sensitive to test setup and proper use. Two (2) grounding strips are provided on top of the unit. These are intended to attach to a counterpoise, which is provided with the unit.

In order to assemble the unit, first touch the two metal counterpoise mounting strips located on top of the antenna chassis, then remove the two screws from each strip. The unit is meant to be under the counterpoise. In this way the body of the unit does not intrude into the field being measured. Open the counterpoise and attach it to the mounting strips using the screws that were just removed. Next, the rod should be attached to the fitting at the center of the unit, through the hole in the counterpoise. The rod should then be extended to 41". The output of the unit should be connected to a 50 ohm receiver, spectrum analyzer, or RF voltmeter. The technician should remove the ESD wrist strap at this time.

The unit is activated by pressing in the power switch on the front panel. The switch will turn to green and the battery low/power indicator light will come on. Should the indicator light not come on, the level of the battery charge should be checked. Finally, the

state of the gain switch should be checked. It is anticipated that in most applications the low gain setting will be used.

The unit housing hangs under the counterpoise with the antenna rod passing through an opening in the counterpoise.

It should be noted that the brass tripod mounting bracket on the bottom of the unit is not a ground location. The unit must be attached to a counterpoise through the top grounding strips. In screen room testing, the counterpoise should be solidly attached to the screen room wall, as required for military testing.

If the unit is to be mounted on a tripod, it is recommended that the tripod be non-conductive.

## HIGH SENSITIVITY READINGS

---

The Model 3301B has been optimized to facilitate extremely sensitive readings. For best performance all internal attenuation should be OFF. The gain switch should be placed in the low gain setting. The noise limiting factor on the 3301B is the high front end impedance presented to the FET. So when the gain stage output is increased with the gain switch, the noise is also amplified and actually increased slightly due to additional noise added in the gain state. The high gain setting is primarily intended to provide additional signal strength for receivers which require it.

A set of minimum discernible signal graphs is included in this manual. These graphs represent the smallest signal which can be detected with the 3301B. The data plotted are the noise output of the unit. Hence, this forms the noise measurement for a signal plus noise to noise ratio of 3 dB. Several typical bandwidths are presented. To calculate the expected sensitivity at some other bandwidth a  $10 \cdot \log$  relation should be used.

**Example:**

Determine the sensitivity with a 3 kHz bandwidth at 1 MHz. The minimum discernible signal (MDS) at 1 MHz with a 1 kHz bandwidth is read from the graph at  $-2$  dBuV/m. The ratio of the bandwidth is  $3/1=3$ . Taking  $10*\log(3)$  we get  $4.77$  dB. So the expected sensitivity would be  $-2\text{dBuV/m}+4.77\text{dB}=2.77\text{dBuV/m}$ .

---

# THEORY OF OPERATION

---

---

## THE ROD

---

There are three (3) factors which are of primary interest in understanding a rod antenna. These factors are its effective electrical length, the impedance it presents to the measurement system, and the interaction of the rod with the ground. The discussion here will contain itself to discussing an electrically short antenna element. The 3301B is designed to be electrically short over its measurement range. By electrically short, we mean an antenna which is designed to have the physical antenna element be short when compared to the wavelength of the highest frequency in its measurement range. The current distribution on any rod antenna will be sinusoidal. If a rod is short enough with respect to the wavelength being measured, that distribution will approach a linear distribution and may be assumed to be linear for all practical purposes. The linear current distribution will allow for linear scaling of the rod length. If the rod length is reduced by half, then the received voltage will be reduced by half. The 41" rod is approximately a meter long. Electrically it then is a half meter long. The assumption of linearity will remain accurate at least to one eighth (1/8) wavelength.

At this point some resonance behavior is possible. A rod which is electrically a half meter is one eighth (1/8) wavelength at 75 MHz. In order to keep the response of the unit linear and avoid resonance behavior, the 3301B pre-amplifier is limited to roll off before this frequency has been reached. However, this avoidance of possible resonance carries the penalty of 6dB on the antenna factor. Since field strength is measured as volts per meter, the measurement must be normalized to 1 meter. This means that 6 dB must be added to a reading taken with a half meter rod.

The second factor which is of concern is the impedance the rod presents to the measurement system. The resistive component is non-significant in this situation. The controlling impedance is the capacitance of the rod to ground. This capacitance may be calculated by the formula:

$$C = [55.63 * h] / [\ln (h/a)]$$

Where “h” is the length of the rod and “a” is its radius, both in meters. The natural logarithm of “h” over “a” is represented by “ln”. For the 3301B rod, the capacitance is 12 picofarads. This capacitance is significant because it combines with the total input capacitance of the amplifier to form a voltage divider. It can quickly be seen that if the FET input capacitance and circuit stray total 12 pF, there will be a 6 dB loss through this stray capacitance. Even if the total input capacitance were reduced to 4 pF there would be a 2.5 dB loss.

Finally, the interaction of the rod with the ground must be understood. The theoretical understanding of the rod assumes that it operates in reference to an infinite ground at 0 Volt potential. The closer the test situation is to this scenario the more accurate will be the readings. A small vestigial ground is provided with the unit in the form of a counterpoise. Care should be taken to reference this counterpoise to true ground.

The procedures for this are carefully explained in various standards. If the counterpoise is not well grounded, an impedance may build up through the cabling and other instrumentation. Reading differences of as much as 20dB can be found with ungrounded counterpoises. This will be true for all rod antennas regardless of their design.

Another counterpoise problem is the potential for positive feedback. Good amplifier design calls for the output to be 180° out of phase with the output signal so that the shield current is in phase with the input. If the shield and counterpoise are tied through the body of the unit, then the counterpoise will receive some of this current. If the counterpoise does not have an extremely low impedance to ground, then this return current can drive a potential on the counterpoise in phase with the input resulting in errant readings. The 3301B has an internal common mode choke to minimize the impact of an inadequate test setup. However, proper test configuration will always be critical to insure measurement accuracy.

Also of concern is the contribution of edge effects from the vestigial ground plane. Most theory is developed on the assumption of one infinite ground plane. How using a small vestigial ground plane or counterpoise affects the theory has not been well studied to date. Even more complicated is the effect of this vestigial ground plane when the unit is used in a screen room with the ground planes on all sides. In practice, the best results are obtained by tightly tying the counterpoise to the screen room through an ultra low impedance ground strap. This at least assures that at the lower frequencies all of these surfaces are at an equal potential.

## THE PRE-AMPLIFIER

---

The 3301B pre-amplifier is designed in two (2) stages. The first stage provides impedance transformation and current gain. The second stage provides voltage gain and impedance mating on a 50 ohm output.

The first stage of the pre-amplifier contains an n-channel JFET and an NPN bipolar silicon transistor. Through the use of extremely precise layout techniques, careful parts selection and feedback to virtually eliminate the Miller effect, the total input capacitance is kept extremely low. This low capacitance in turn allows for an extremely high input impedance.

It is the output impedance which determines the effective low frequency cutoff of the unit. The 3301B is still usable at an extremely low 30 Hz. In fact, artificial limiting had to be introduced to protect the unit in situations where overloading from power frequencies would be a problem. The low frequency roll off switches in to unit allow the user to set the unit's low frequency cutoff according to his particular testing needs.

The second stage is made up of three (3) exceptionally high quality transistors. The first is configured common emitter for voltage gain and to give a precise 180° phase reversal for the output. The second two transistors for a Darlington pair to drive the 50 ohm output. The output of this stage is then DC isolated, matched to 50

ohm and passed through a common mode choke. The result is that cable VSWR and common mode noise problems are minimized.

The dynamic limits of the 3301B are set by the amplifier. Sensitivity is determined by the noise developed in the first stage. The ultimate limit on sensitivity is determined by the thermal noise generated by the input impedance. The impedance presented to the amplifier by the rod is almost entirely capacitive. A 41" rod typically presents an impedance of about 12 pF. So the input impedance presented to the amplifier will decline with increasing frequency. At the low frequencies, where the input impedance is high, the thermal noise generated by this impedance will also be high. If the input impedance of the amplifier is lowered to reduce thermal noise then the rod will be loaded down and lose sensitivity. This combination of thermal noise and rod impedance sets an ultimate limit on the sensitivity achievable by active rod antennas. The sensitivity of the 3301B improves with frequency in direct relation to the declining input impedance.

A common mistake made in regard to sensitivity is to ask what the noise figure of an active rod is. Noise figure is defined as "the ratio of output noise of a unit over the output noise expected solely due to the thermal noise of the resistance of the input impedance." Since the input in the case of a rod is primarily reactive, the definition literally has no meaning. What is useful is to determine what the minimum discernible signal of a unit is. That is, what is the smallest signal which can be seen in the presence of the amplifier noise? There is a trick here. The smallest signal seen above the noise in a rod antenna is not determined by the noise of the amplifier. Signal is drained away through capacitive loss before it reaches the amplifier. An amplifier with more noise may actually be more sensitive if it also loses less signal to capacitance at the input.

The upper limit of the 3301B is determined by the ability of the gain stage to amplify a signal. The gain stages capable of handling field strengths of 0.7 V/M are available. Impulsive type signals produce the same effect but in such a way as may not be immediately obvious. An impulse signal presents the amplifier with signals at a number of frequencies all in phase with each other



so that measurement of the field strength at any one frequency will not appear to be very high. However, the amplifier is being called upon to amplify signals at many frequencies simultaneously. In the time domain, the amplifier would be seen to be presented with quite a large power demand. The result is that impulsive signals appear to saturate the amplifier at much lower signal levels. The 3301B has been measured to begin going non-linear at 64 dBuV/m/MHz.

A saturation indicator is provided on the unit. This indicator will eliminate many false readings due to non-linear operation. The saturation indicator has been carefully tested to give an accurate, early warning of possible saturation. However, some types of impulse signals may not trigger the indicator. The user must, therefore, be careful to observe the published limits. Should these be exceeded the internal attenuation provided will relieve the problem.

## THE ANTENNA FACTOR

---

The antenna factor data provided with the unit is simply a ratio of the field strength presented to the unit to the voltage output from the unit at that field strength. By adding the antenna factor to a given output, the field strength may be derived. The antenna factor in the 3301B combines several factors. The first factor is the 6 dB required to normalize the rod to 1 meter. The next is the measured capacitive loss at the front of the unit of about 4 dB. Then there is the gain of the amplifier itself, 15 dB. Finally, 6 dB is required in order to conjugate match the output to 50 ohm. The antenna factor is the sum of these factors. A typical result might be:

- 6 dB Rod Normalization
- 4 dB Capacitive Loss
- +15 dB Preamplifier Gain
- 6 dB 50 ohm Matching Loss
- 1 dB Gain Over Field Strength or Antenna Factor of 1 dB

---

# ANTENNA IMPULSE RESPONSE

---

The Model 3301B was designed and optimized for the measurement of CW type signals. However, this unit is fully capable of dealing accurately with impulsive type signals, with some special considerations. This section is intended to guide the user who intends to use the 3301B to measure impulsive signals. By following the guidance given here accurate measurements of impulsive signals may be performed. The 3301B may be used to measure all of the important characteristics of an impulse signal which falls within its bandwidth and dynamic range. However, the measurement of impulsive signals requires some special cautions to avoid saturation of the antenna amplifier.

---

## IMPULSE CHARACTERISTICS

---

Before discussing the 3301B response to impulse signals, a brief review of the nature of impulse signals is appropriate. For our purposes we will consider a specific type of impulse signal, the periodic, rectangular pulse. The pulse may be described by three (3) parameters: the pulse width,  $t$ , the pulse repetition rate,  $PRF$ , and the pulse amplitude  $A$  (See Figure 1). By Fourier analysis, we may convert this time domain representation into its frequency domain equivalent. In the frequency domain, the impulse becomes an infinite series of discrete spectral lines whose envelope is described by the formula,

$$Y=K*\sin(x)/X$$

Where,

$$K=A*t*PRF$$

The nulls occur at regular intervals spaced  $n/t$  apart, where  $n$  is an integer. The discrete spectral lines are spaced evenly, at internal multiples of the  $PRF$  (See Figure 2). Two (2) characteristics should be noted. First, that increasing the pulse width,  $t$ , narrows the separation of the nulls. So wider pulses tend to concentrate their energy in a narrower frequency span. Second, decreasing the  $PRF$  decreases the frequency separation of the individual spectral lines (See Figure 3).

By considering the frequency domain representation, any antenna's response to an impulse may be understood. The antenna will only pass those spectral components which fall within its bandwidth. In the case of the 3301B, components above 30 MHz will be attenuated or not passed at all. Remember, that to fully describe a rectangular pulse, an infinite bandwidth is required. The lack of high frequency components shows up on the time domain as a rounding of sharp corners and a slowing of the rise and fall.

In the same way the antenna will not efficiently pass spectral components which fall below its bandwidth. For the 3301B, the low frequency roll off which is selected will determine how wideband the response is. The very low frequency components basically describe the flat top and bottom of the time domain pulse. So, when the waveform is band limited by the antenna, the resulting waveform will have a decay constant returning the output to ground rather than maintaining a flat topped pulse.

A third phenomenon which occurs when measuring impulse type waveforms is that saturation of the amplifier is harder to detect. By definition, impulsive type signals spread their energy over many spectral components. So, when viewed in the frequency domain, the energy demanded of the antenna amplifier may appear much lower than it in fact is. The energy demanded of the antenna amplifier to properly pass a pulse is not just the peak pulse in the frequency domain waveform, but rather the sum of the energy contained in all the spectral lines. By looking in the time domain, it is easy to see that the amplifier must provide the energy to go from ground to the pulse peak almost instantaneously. The impulse delivers all its frequency domain spectral components in phase. So the antenna must provide the vector sum of all the frequency domain spectral lines. Thus extra care must be taken to protect the antenna amplifier from saturation when making impulse measurements in the frequency domain. The internal attenuators in the 3301B allow it to overcome many of the barriers which earlier units presented to such measurements. These attenuators allow the user to safely keep the amplifier in its linear region.

The saturation indicator in the 3301B will provide an accurate warning of impending saturation, provided two (2) conditions are

met. First, the product of the pulse width to pulse repetition rate must be greater than 0.003. Second, the pulse repetition rate must be less than the value listed for the applicable duty cycle given in the following chart:

Duty Cycle	Maximum PRF
10	19.7 MHz
20	14.0 MHz
30	9.2 MHz
40	5.6 MHz
50	420.0 kHz
60	130.0 kHz
70	87.0 kHz
80	57.0 kHz
90	30.0 kHz

If an impulse falls outside of these two (2) parameters, the saturation indicator will not accurately warn of saturation. However, the antenna will accurately handle the impulse signal within its bandwidth and dynamic range limitations.

The reasons for these requirements are two (2) engineering trade-offs which must be made, and are explained in the next two (2) sections.

## PULSE DESENSITIZATION

The 3301B saturation indicator operates by creating a DC level on a capacitor fed through a rectifying diode. This DC level is then compared to a second DC level which is set at the amplifier's 1 dB compression point. This circuit works extremely well for CQ type signals. However, for fast transients the capacitor, like all capacitors, has an integrating effect. The DC level established by a fast transient is spread out in time. After the pulse passes, the capacitor begins to discharge through its resistance to ground. If the PRF is slow enough so that the capacitor is fully discharged before the next pulse arrives, it may never trigger the indicator. The antenna amplifier, on the other hand, must satisfy the instantaneous energy demand. It must respond to the peak demand without any integrating effect. If the product of the pulse width and

PRF is less than 0.003, the saturation indicator will fail to indicate properly. The time constant of the saturation indicating capacitor also sets the persistence of the saturation circuit. In order to have the saturation circuit cease to indicate saturation within a reasonable time after the antenna moves out of saturation, a reasonable RC time constant must be maintained. This choice of RC time constant also creates this limit for impulsive signals. In this region, the user must closely monitor the antenna output for saturation.

## PULSE CHARGING

---

The second criterion which must be met is that the PRF must fall below the rate listed in the previous section on “Impulse Characteristics” for the appropriate duty cycle. This requirement is created by the AC coupling in the 3301B circuitry. In order to allow maximum dynamic range through the 3301B, the various stages are AC coupled. Furthermore, in order to allow the extremely broad bandwidth of the unit, large value, low impedance capacitors are used to provide the AC coupling. When a pulse passes through these capacitors, a charge is developed. After the pulse passes, this charge drains through the associated resistance to ground at an established RC constant. However, if the next pulse occurs before the residual charge has fully discharged, then a residual DC bias is created.

This bias artificially alters the DC level on the saturation indicator comparison capacitor causing it to fail to properly indicate saturation. Again, in this region, the user must closely monitor the antenna output for saturation.

# CALIBRATION PROCEDURE

ETS-Lindgren recommends the equivalent capacitance method of calibration for its 3301B active rod antenna. In order to check the calibration a 3301B calibration test fixture is required. This fixture contains a resistive “T” and a capacitor. The “T” allows for accurate reading of the input to the fixture. The capacitor feeds the amplifier through the same impedance as the 41” rod presents to it. The result is a simple, yet extremely accurate calibration.

Periodic checks of the unit’s performance are recommended. In order to calibrate the unit, simply attach the calibration fixture and ground it to the 3301B housing through one of the counterpoise mounting holes. Place a signal source on one leg of the fixture and a receiver on the other leg. Then terminate the output of the unit with 50 ohms. Read the input signal strength. The input signal strength measured through the calibration fixture must have 11 dB added to it. The 11 dB is composed of 6 dB required to normalize the rod to 1 meter and 5 dB of signal loss through the resistive divider in the “T”. After the input is read, move the receiver cable to the output of the unit and place a 50 ohm load on the now open leg of the calibration fixture. Read the unit output. The antenna factor is the input plus 11 dB minus the output, both readings assumed to be logarithmic.

ETS-Lindgren recommends the following input voltage levels for field calibration:

Voltage	Internal Attenuation
250 mV	0 dB
450 mV	10 dB
8 V	30 dB

Table 1. Voltage Settings for Field Calibration

Example:

Suppose a reading is taken with a 1 MHz signal input to the calibration fixture. The input is read as 50 dBuV and the output is

read as 59 dBuV. The antenna factor is then the input plus 11 dB minus the output of 50 dBuV + 11 dB – 59 dBuV = 2 dB.

## 3301B PARTS LIST

---

Item	Number
1. Collapsible Rod Element 41"	101263C
2. 24" x 24" Counterpoise	100692
3. Rod Antenna Pre-Amplifier	100697B
4. Battery Charger	102615
5. Model 3301B Manual	399046

## ACCESSORIES AVAILABLE

---

Accessory	Model Number
1. 3301B Calibration Fixture	3301CB
2. Tripod, Linen Phenolic	3-TR
3. Remote Status Monitor	3301B-RM
4. Extra 3301B Manual	399046
5. 25" Cable RG-223/U with BNC Connectors	C-BNC
6. Replacement Batteries, 6V (2 required)	400009

## MAINTENANCE

---

To ensure reliable and repeatable long-term performance, annual recalibration of your antennas by ETS-Lindgren's experienced technicians is recommended. Our staff can recalibrate almost any type or brand of antenna. Please call to receive a service order number prior to sending an antenna to us for calibration.

For more information about our calibration services or to place an order for antenna calibration visit our calibration website at <http://www.antennacalibration.com/>.

# WARRANTY STATEMENT

---

**ETS-Lindgren L.P.**, hereinafter referred to as the Seller, warrants that standard EMCO products are free from defect in materials and workmanship for a period of two (2) years from date of shipment. Standard EMCO Products include the following:

- ❖ Antennas, Loops, Horns
- ❖ GTEM cells, TEM cells, Helmholtz Coils
- ❖ LISNs, PLISNs, Rejection cavities & Networks
- ❖ Towers, Turntables, Tripods & Controllers
- ❖ Field Probes, Current Probes, Injection Probes

If the Buyer notifies the Seller of a defect within the warranty period, the Seller will, at the Seller's option, either repair and/or replace those products that prove to be defective.

There will be no charge for warranty services performed at the location the Seller designates. The Buyer must, however, prepay inbound shipping costs and any duties or taxes. The Seller will pay outbound shipping cost for a carrier of the Seller's choice, exclusive of any duties or taxes. If the Seller determines that warranty service can only be performed at the Buyer's location, the Buyer will not be charged for the Seller's travel related costs.

This warranty does not apply to:

- ❖ Normal wear and tear of materials
- ❖ Consumable items such as fuses, batteries, etc.
- ❖ Products that have been improperly installed, maintained or used
- ❖ Products which have been operated outside the specifications
- ❖ Products which have been modified without authorization
- ❖ Calibration of products, unless necessitated by defects

**THIS WARRANTY IS EXCLUSIVE. NO OTHER WARRANTY, WRITTEN OR ORAL, IS EXPRESSED OR IMPLIED, INCLUDING BUT NOT LIMITED TO, THE IMPLIED WARRANTIES OF MERCHANTABILITY AND FITNESS FOR A PARTICULAR PURPOSE. THE REMEDIES PROVIDED BY THIS WARRANTY ARE THE BUYER'S SOLE AND EXCLUSIVE REMEDIES. IN NO EVENT IS THE SELLER LIABLE FOR ANY DAMAGES WHATSOEVER, INCLUDING BUT NOT LIMITED TO, DIRECT, INDIRECT, SPECIAL, INCIDENTAL, OR CONSEQUENTIAL DAMAGES, WHETHER BASED ON CONTRACT, TORT, OR ANY OTHER LEGAL THEORY.**

*Note: Please contact the Seller's sales department for a Return Materials Authorization (RMA) number before shipping equipment to us.*



# EUROPEAN COMMUNITY DECLARATION OF CONFORMITY

---

The EC Declaration of Conformity is the method by which EMC Test Systems, L.P. declares that the equipment listed on this document complies with the EMC and Low-voltage Directives.

**Factory:**

EMC Test Systems, L.P.  
P.O. Box 80589  
Austin, Texas USA  
78708-0589

**Issued by:**

EMC Test Systems, L.P.  
P.O. Box 80589  
Austin, Texas USA  
78708-0589

**The products manufactured under the EMCO product name and listed below are eligible to bear the EC Mark:**

Model 3301B Active Rod Antenna  
Part Number 102615 Battery Charger

**Applicable Requirements:**Standard

EN61010-1

EN60742/1989

EN55022

IEC 801-2

IEC 801-3

IEC 801-4

Criteria

Safety requirements for electrical equipment for measurement, control and laboratory use

Isolating transformers and safety isolating transformers

Class B

Level 2 4/8kV

Level 2 3V/m

Level 2 .5 I/O, 1kV AC

**Authorized Signatories**

  
Bruce Butler, General Manager

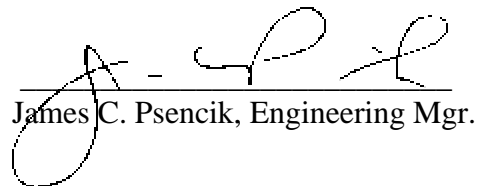
  
James C. Psencik, Engineering Mgr.

  
Charles Garrison, Quality Assurance

**Date of Declaration: December 10, 1996**

The authorizing signature on the EC Declaration of Conformity document authorizes EMC Test Systems, L.P. to affix the CE mark to the indicated product. CE marks placed on these products will be distinct and visible. Other marks or inscriptions liable to be confused with the CE mark will not be affixed to these products. EMC Test Systems, L.P. has ensured that appropriate documentation shall remain available on premises for inspection and validation purposes for a period of no less than 10 years.

## DATA AND ILLUSTRATIONS

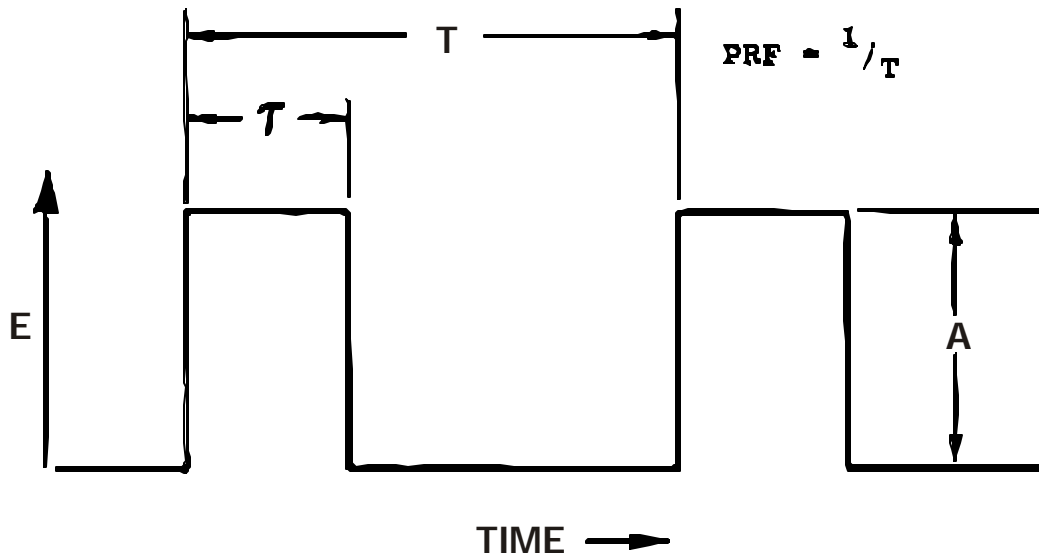

FIGURE 1. PERIODIC RECTANGULAR PULSE TRAIN.

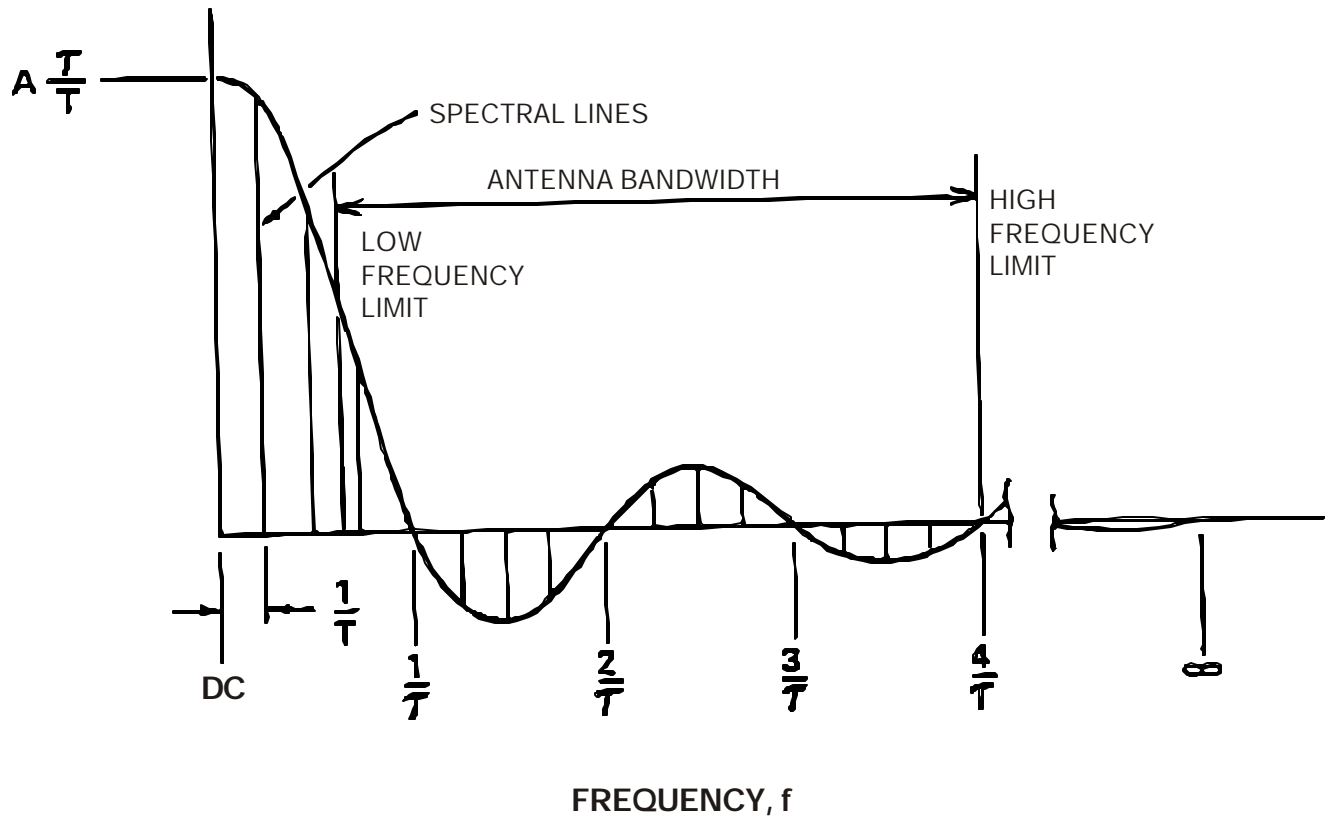

FIGURE 2. SPECTRUM OF A RECTANGULAR PULSE. AMPLITUDES AND PHASES OF AN INFINITE NUMBER OF HARMONICS ARE REQUIRED TO FULLY DESCRIBE THE ENVELOPE.

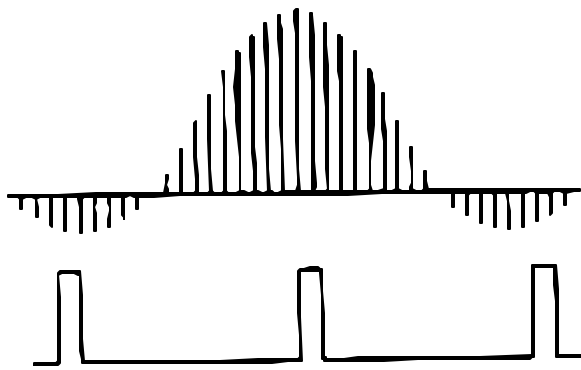

FIGURE 3A.

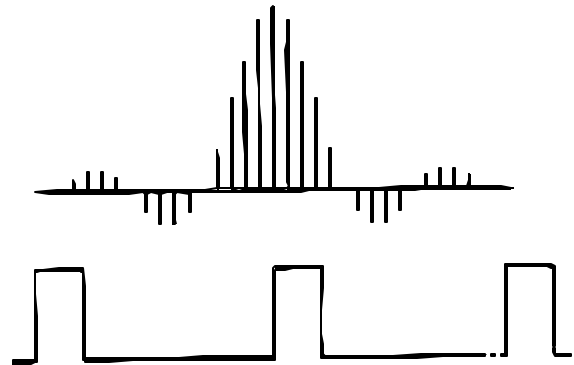

FIGURE 3B.

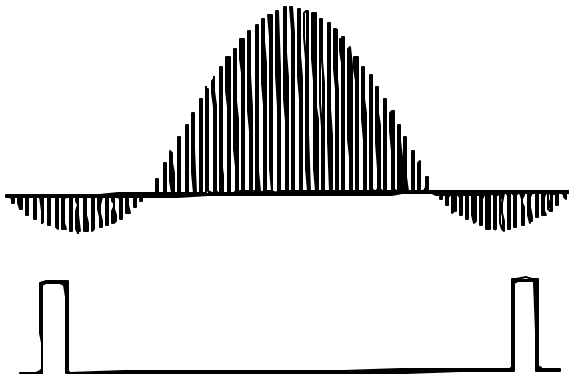

FIGURE 3C.

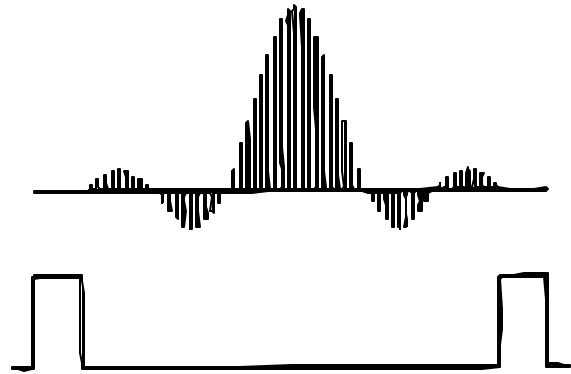
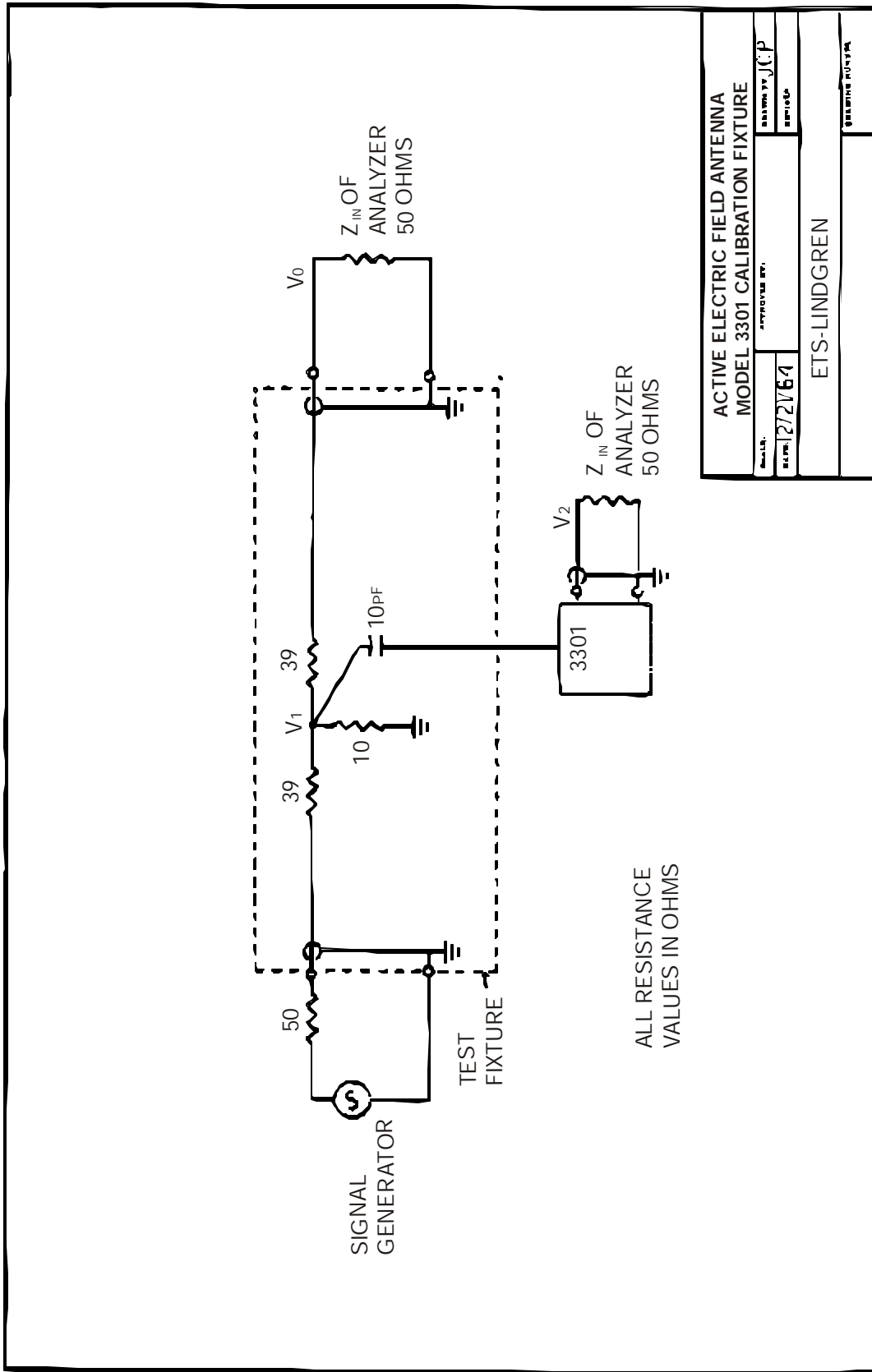
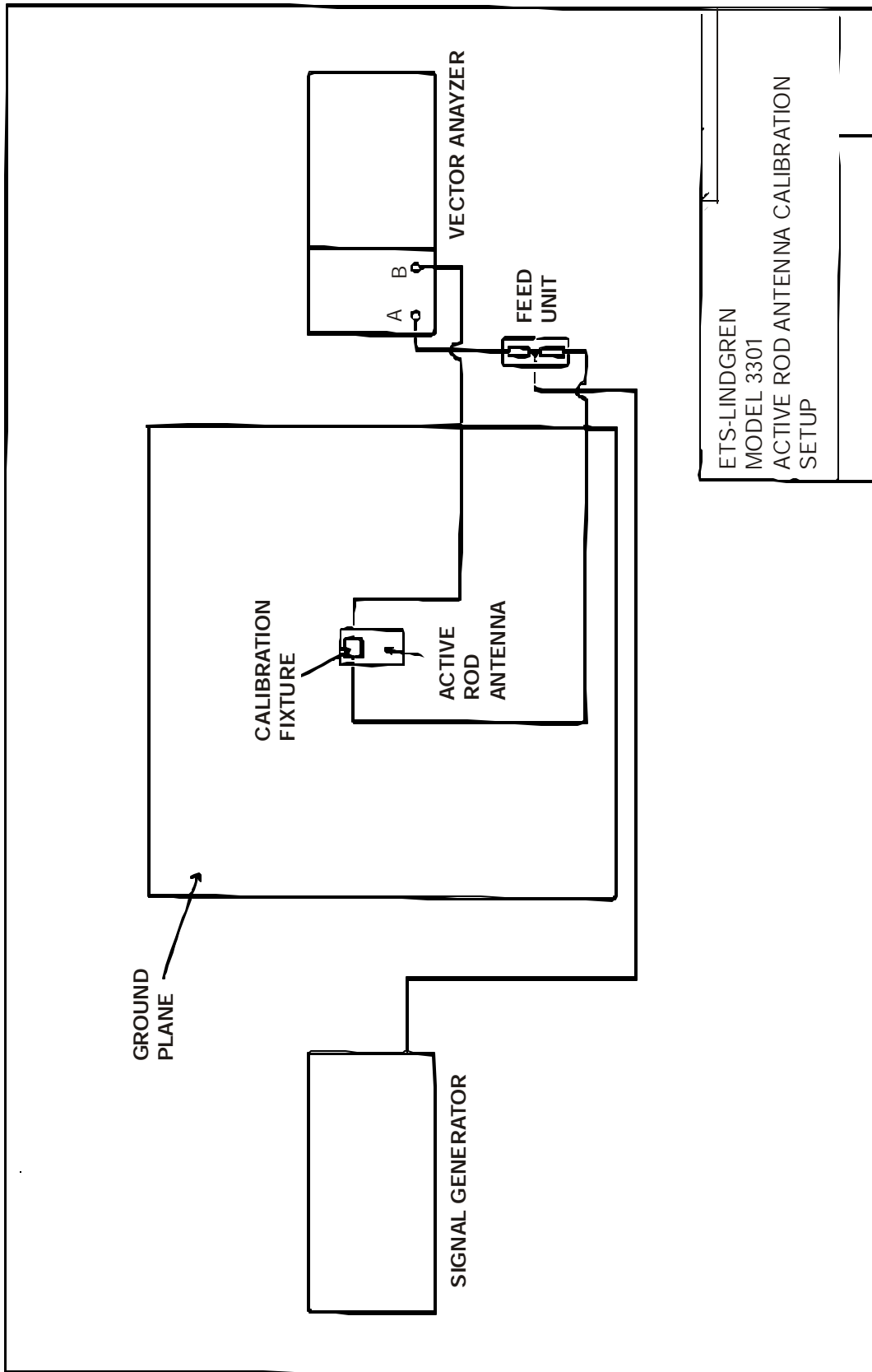
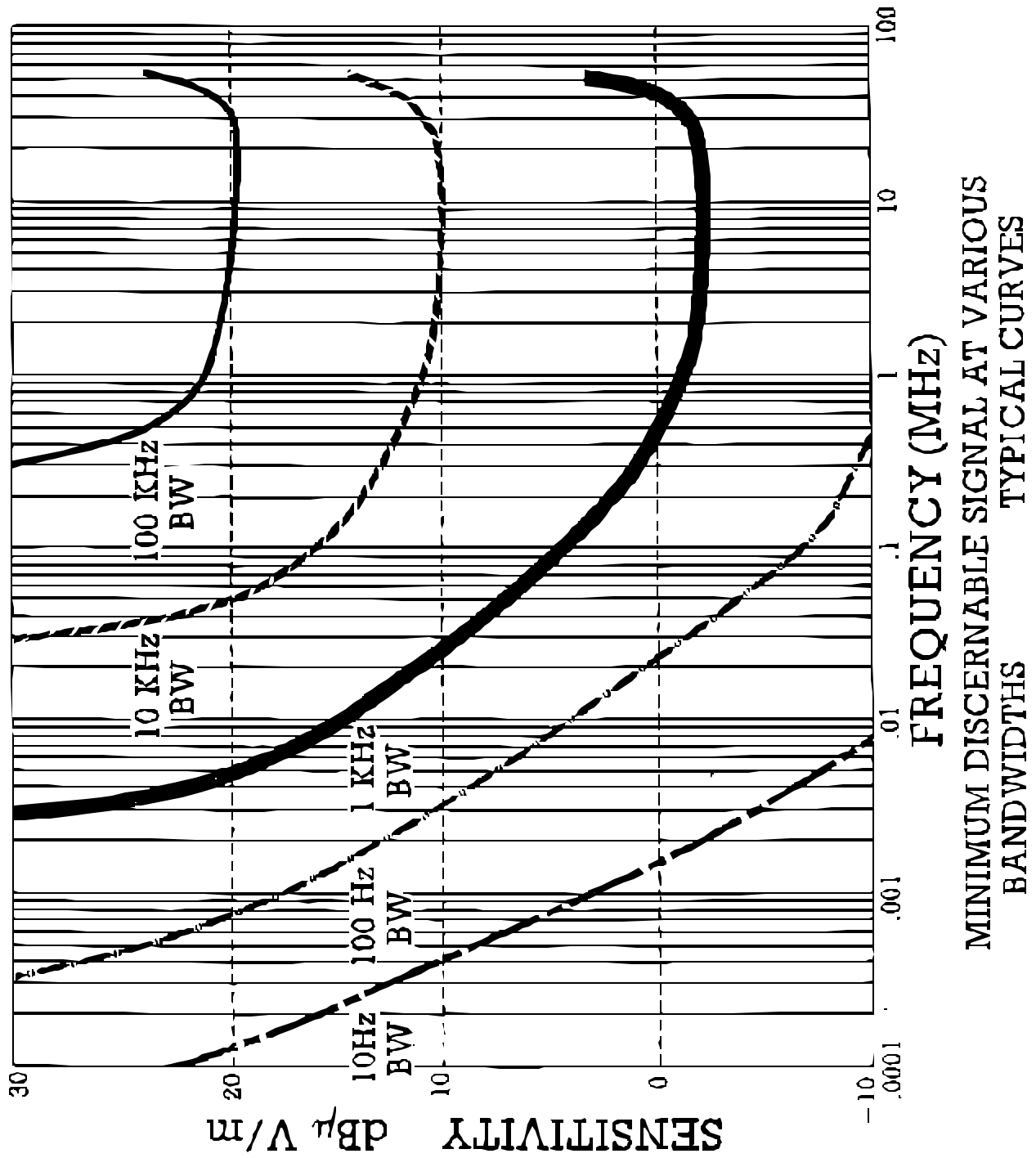

FIGURE 3D.

FIGURE 3. FIGURES 3A TO 3D DEPICT THE EFFECT OF ALTERING EITHER THE PULSE WIDTH OR PULSE REPETITION RATE. A NARROW PULSE WIDTH (3A, 3C) SPREADS THE PULSE ENERGY OVER A WIDER FREQUENCY BAND. WIDER PULSES (3B, 3D) CAUSE NARROWER LOBES. A LOW PULSE REPETITION RATE (3A, 3B) CREATES WIDELY SPACED SPECTRAL LINES. FASTER RATES (3C, 3D) INCREASE THE SPECTRAL LINE DENSITY.







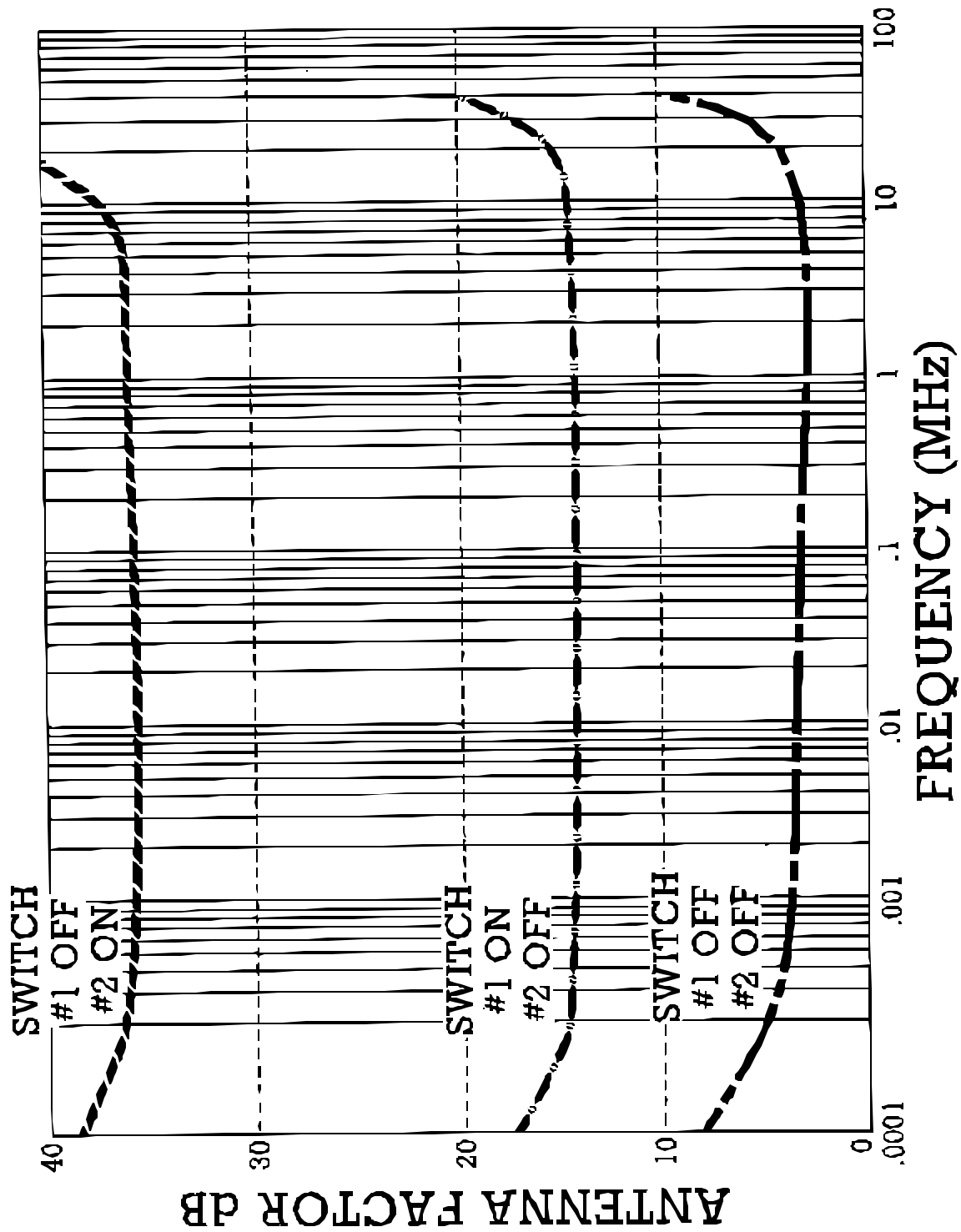

TYPICAL ATTENUATION EFFECT FOR SWITCHES #1 AND #2



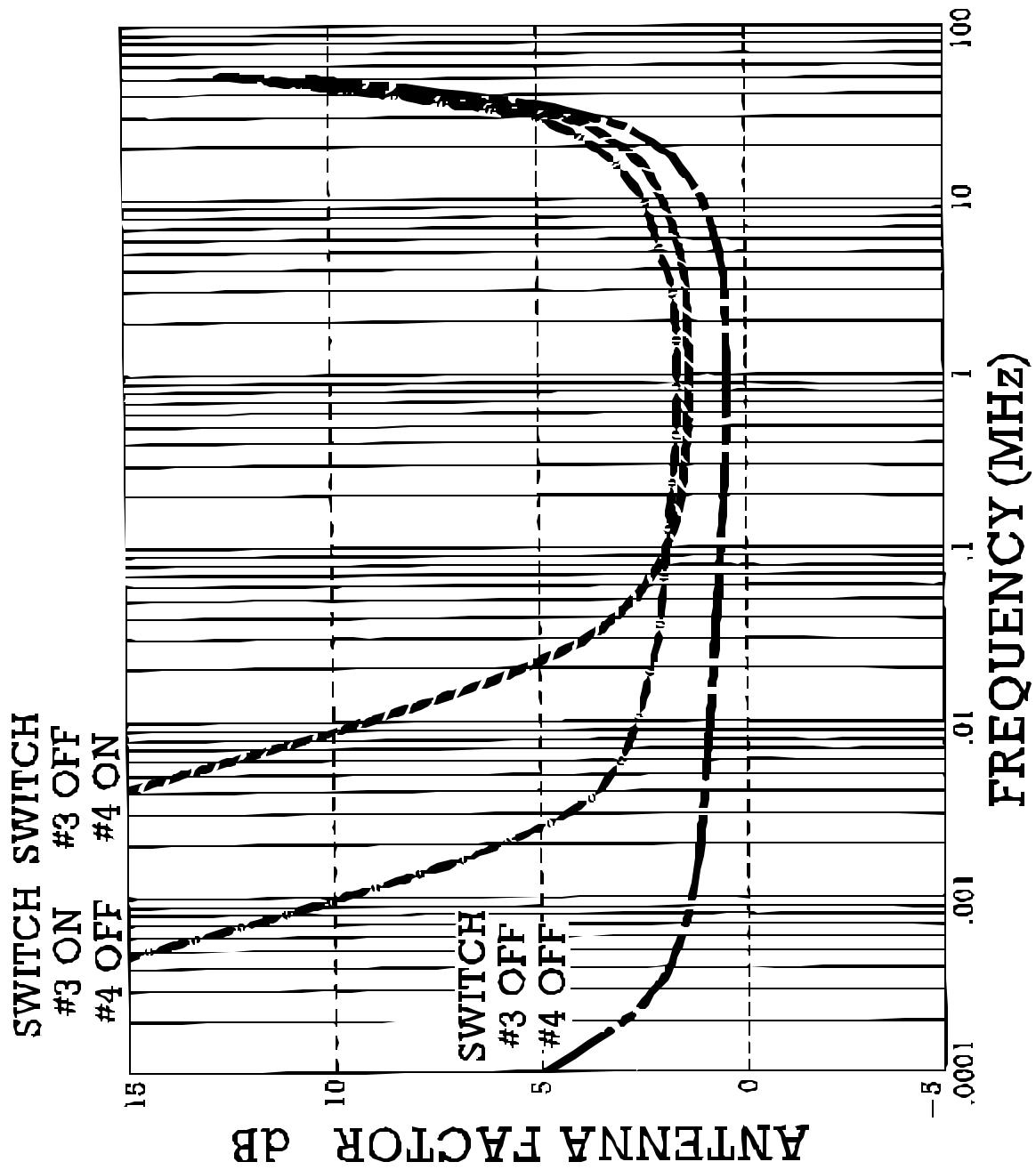

TYPICAL ROLL OFF CURVES FOR SWITCHES #3 AND #4

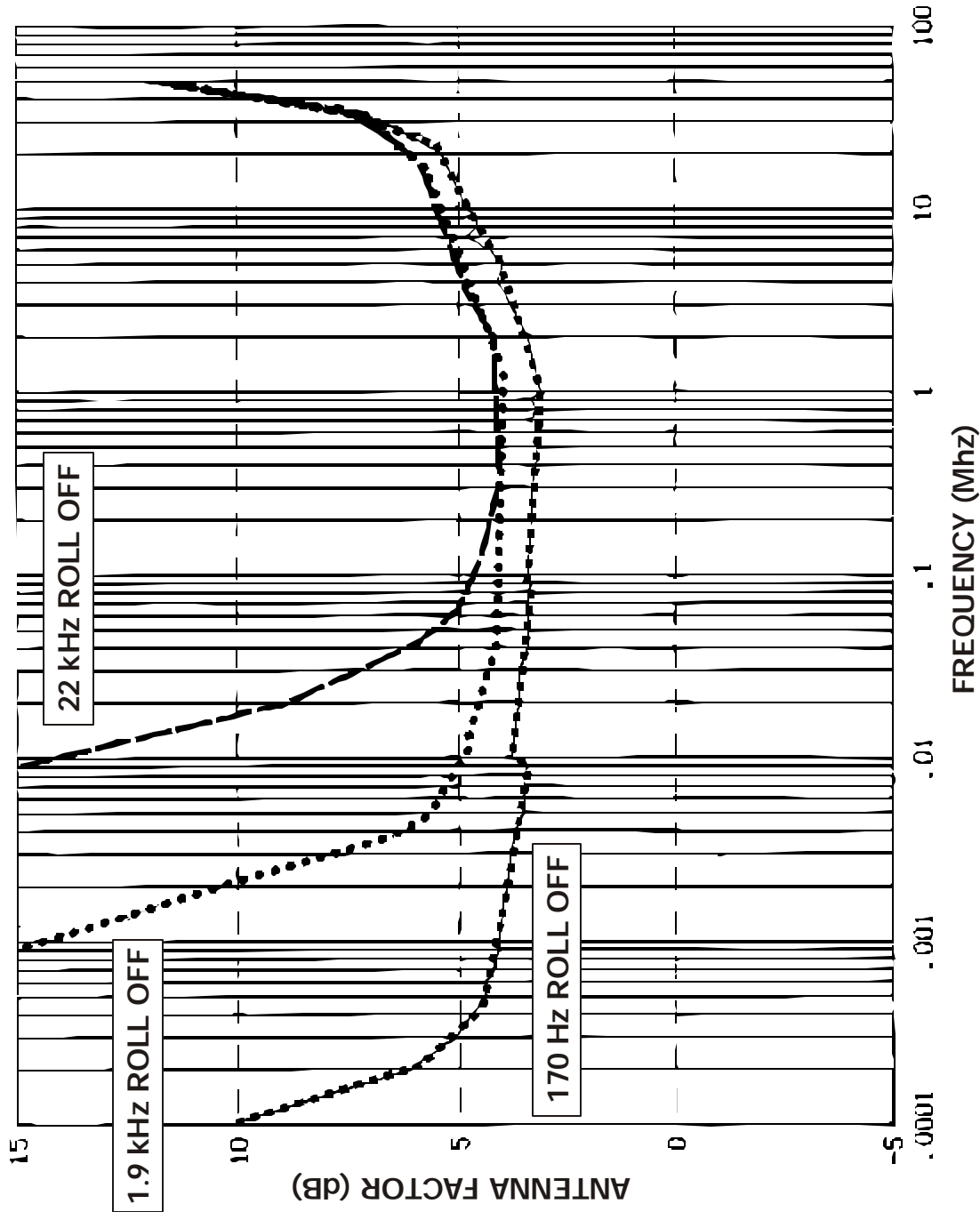

41" ROD ANTENNA (0 dB ATTENUATION)  
TYPICAL ROLL OF CURVES  
GENERATOR OUTPUT 250 mV

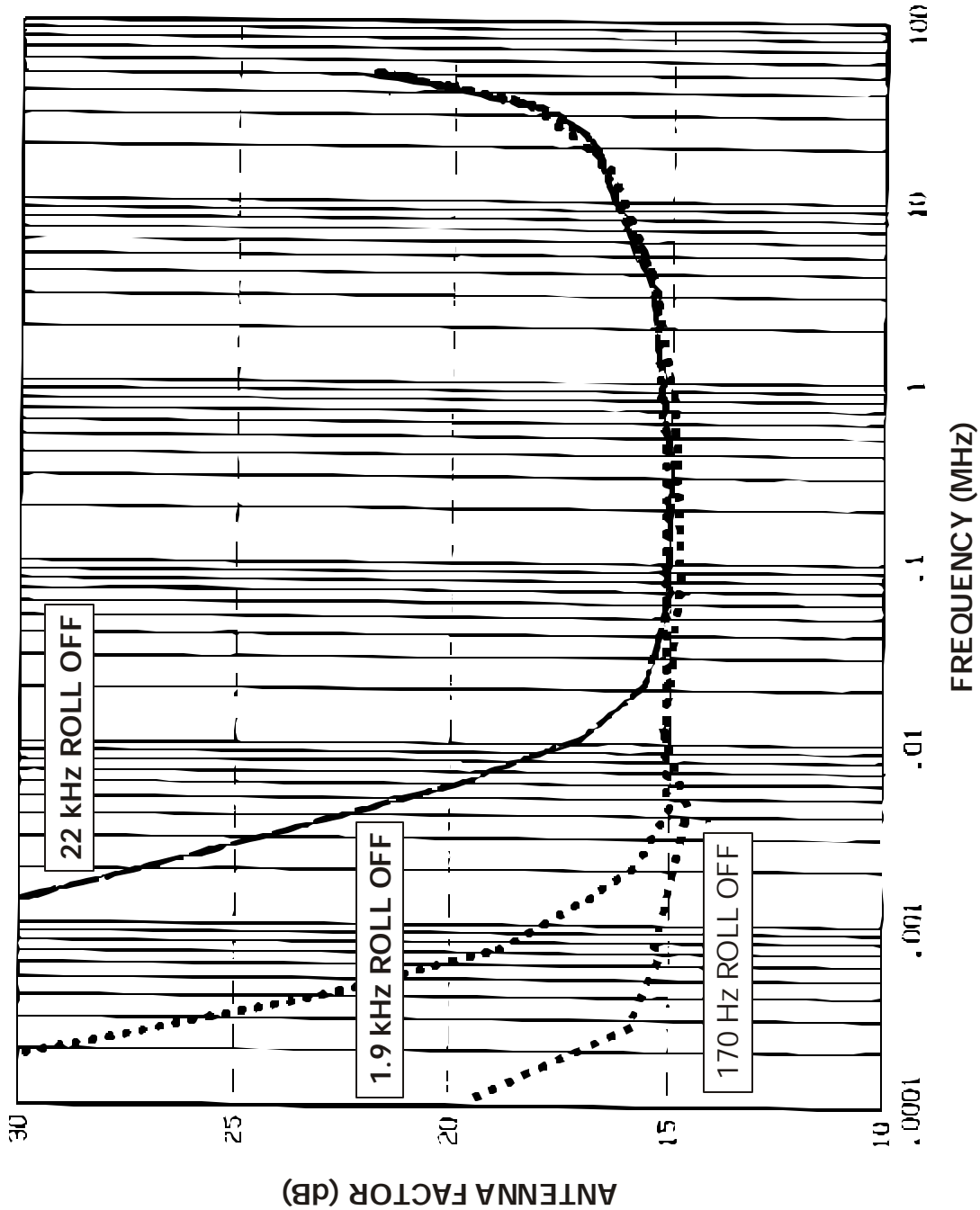

41" ROD ANTENNA (10 dB ATTENUATION)  
TYPICAL ROLL OFF CURVES  
GENERATOR OUTPUT 250 mV

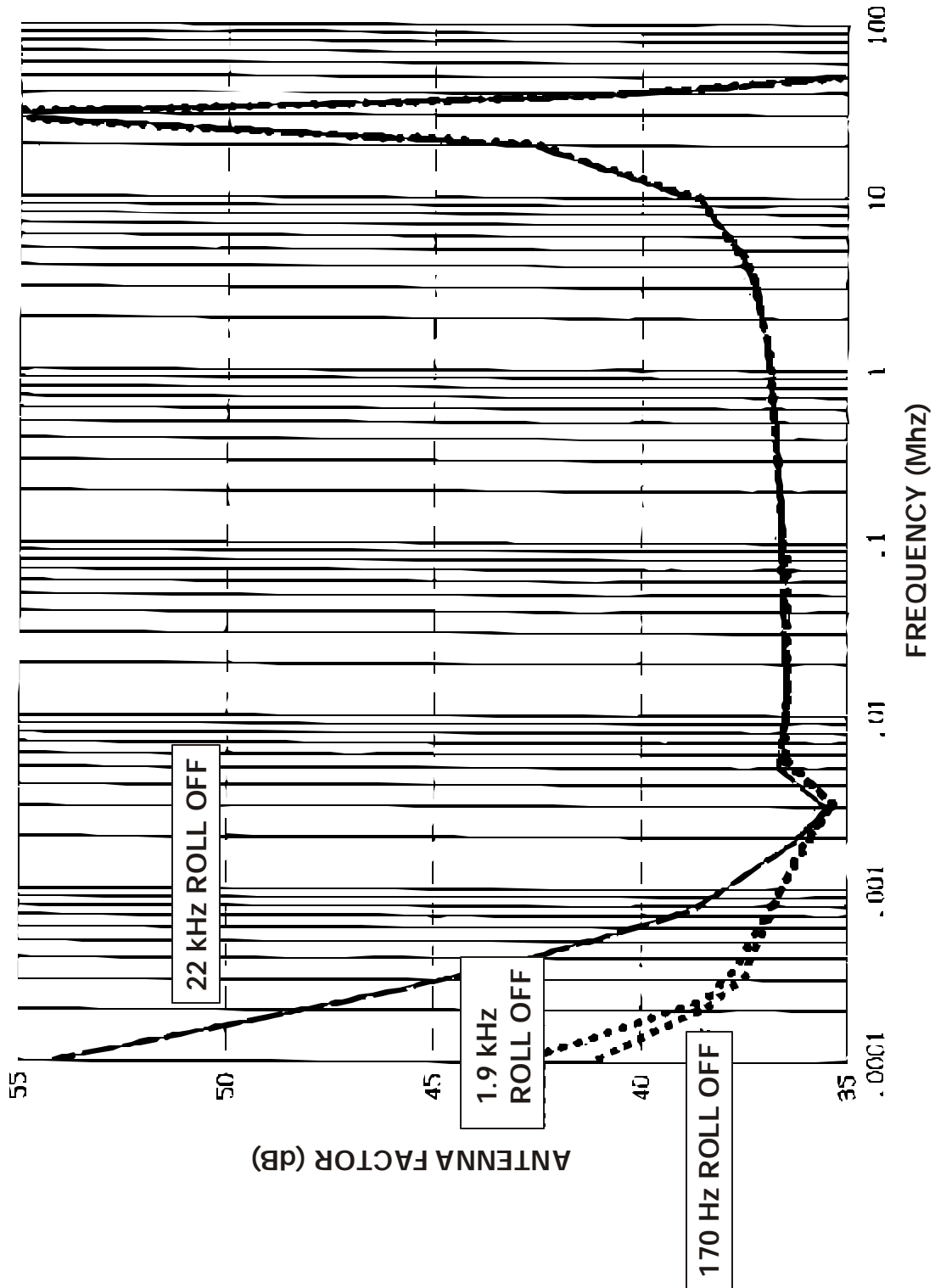

41" ROD ANTENNA (30 dB ATTENUATION)  
TYPICAL ROLL OFF CURVES  
GENERATOR OUTPUT 8000 mV