



DLF-400-200-1500

OPERATOR'S MANUAL

DYNALOAD DIVISION
36A NEWBURGH ROAD, HACKETTSTOWN, NJ 07840
Phone (908) 850-5088 Fax (908) 850-0679

T A B L E O F C O N T E N T S

<u>SECTION</u>	<u>PAGE</u>
1. INTRODUCTION	1
2. SPECIFICATIONS	2
3. OPERATING INSTRUCTIONS	4
3.1 Constant Resistance Mode	5
3.2 Constant Current Mode	5
3.3 Pulse Mode	6
3.4 External Modulation	7
3.5 Power Rating	8
3.6 Protective Circuits	8
3.7 Special Applications	8
3.8 Effects of Cable Inductance on Pulse Loading	9
4. CALIBRATION PROCEDURES	11
4.1 Current Sample Calibrate	11
4.2 Remote Programming	11
4.3 Voltmeter Calibrate	11
4.4 Ammeter Calibrate	12
4.5 Constant Current Calibrate	12
4.6 Constant Resistance Calibrate	12
4.7 Current Limit Calibrate	13
4.8 Power Limit Calibrate	13
4.9 Overvoltage Calibrate	13
<u>ILLUSTRATIONS</u>	
Front Panel Layout	14
Calibration Setup	15
Printed Circuit Board Layout	16
Schematic	17

1. INTRODUCTION

The Dynaload is a precision instrument which simulates electrical loads to test power supplies, generators, servo systems, batteries, and similar electrical power sources. It simulates, at the option of the user, resistive loads (amps/volt) or may be switched to a constant current load characteristic (current regulated at a pre-selected value). Provisions are also made for external programming in automated test setups. The external programming voltage is from 0-10V, with an input impedance of 10K minimum. Load current is directly proportional to the programming voltage.

The meter normally reads average pulse current, so for accuracy when loading in the pulse mode it is recommended to monitor the current sample output.

The circuit breaker used to connect the source to the power devices in the load is electronically controlled and senses overvoltage.

In the event of an overvoltage condition protection circuits open the electronic circuit breaker. In the event of an overcurrent or overpower condition, circuitry is activated to limit the load current.

2. SPECIFICATIONS

The following specifications apply:

Load Voltage:	0-400V
Load Current:	0-200A
Average Power Dissipation:	0-1500W
Self-Protection:	

Overvoltage--less than 420V

Overcurrent--less than 220A
Over-power --less than 1800W

Front Panel Switches - Refer to front panel layout

S101 AC, Power ON/OFF Switch
S1 Voltmeter Range Select Switch
S2 Ammeter Range Select Switch
S3 DC Load ON/OFF Switch

MODE SELECTION

S4 20A DC LOAD - 0 to 20A constant current mode which is controlled by the front panel DC Load adjust.

S5 200A DC LOAD - 0 to 200A constant current mode which is controlled by the front panel DC Load adjust.

S6 6A/V DC LOAD - 0 to 6A/V constant resistance mode which is adjusted by the front panel DC Load adjust.

S7 60A/V DC LOAD - 0 to 60A/V constant resistance mode which is adjusted by the front panel DC Load adjust.

S8 20A PULSE LOAD - 0 to 20A pulse mode. The amplitude, frequency, duty cycle and DC baseline are adjustable by the front panel controls.

S9 200A PULSE LOAD - 0 to 200A pulse mode. The amplitude, frequency, duty cycle and DC baseline are adjustable by the front panel controls.

S10 REMOTE PROGRAM - In this mode the user can program the current level with a 0 to 10V programming voltage applied to J101 on the rear panel. The front panel controls are locked out.

S11 SHORT CIRCUIT - Drives load to saturation. Effective resistance is less than .03 ohms.

FRONT PANEL ADJUSTMENTS

Refer to Front Panel Layout.

DC Load Adjust - Coarse and fine adjust controls with a 10 to 1 ratio for precise setting of load current for the constant resistance and constant current functions. This control is also functional in the pulse mode to adjust the DC load component.

Pulse Amplitude - Coarse and fine adjust controls with a 10 to 1 ratio for setting the peak current in the pulse mode, the maximum setting is 200 Amps peak.

Freq. Adj. - Coarse and fine controls adjust the frequency of the pulse generator.

Width - Adjusts the percentage of the on time to off time ratio of the pulse generator a minimum of 10% on time, to maximum of 90% on time can be achieved.

FRONT PANEL STATUS INDICATORS

DC This indicator is on when the DC circuit breaker is engaged.

OV When an overvoltage condition exists this alarm will light and the DC breaker will disengage.

OC This alarm will light when the Dynaload is in current limit.

OP This alarm will light when the Dynaload has reached power limit.

OT If the Dynaload reaches overtemperature this alarm will light and the load will stop drawing current.

LOC This indicator will be on when one of the local modes are selected.

REM This indicator will light when the Dynaload is in the remote programming mode.

REAR PANEL CONNECTIONS

E+ Positive Load Input
E- Negative Load Input

J103 AC, Input Connector
J101 Program Input Connector

3. OPERATING INSTRUCTIONS

The following procedure is recommended for connecting the Dynaload: The AC and DC Dynaload switches should be turned off so that the load is disconnected. The load adjustment controls should be set in the counterclockwise position. The mode selector switch should be set to the appropriate mode to be used. The Dynaload should be plugged into standard 115V, 50-60 Hz power (optional input voltage ranges are available), and connections should be made from the source to be tested to the appropriate load terminals of the dynaload. (E+ and E- on the rear of the unit.) If external modulation is to be used, the external programming voltage should also be connected.

With the AC power switch on, the digital meters should turn on. The DC-on should now be actuated. The front panel Dynaload voltmeter should indicate the source voltage. (If the circuit breaker does not close, or if there is no indication of source voltage, check all the external connections for voltage and polarity.) The load may now be increased by turning the load adjust controls clockwise until the appropriate load is obtained. External instrumentation may be used to monitor current waveforms and eliminate the effects of line voltage drops at high currents.

3.1 Constant Resistance Mode (Amps/Volt)

Two scales are provided, 0-6A/V and 0-60A/V. Minimum resistance on the 0-6A/V range is .166 ohms, and minimum resistance on the 0-60A/V range is .0166 ohms. For example, to test a 12V battery with a two ohm resistive load, the 6A/V mode should be selected, and the coarse and fine load adjust controls adjusted to obtain the 6A load. The two ohm load is now set, and this resistance value will remain constant for the full range of input voltage.

The resistive load characteristics of the dynaload simulate a pure resistance down to approximately 1 to 2V input; i.e., for a given resistance setting, the current is directly proportional to the voltage over wide dynamic ranges. In the very low voltages, the power transistors will saturate.

3.2 Constant Current Mode

Some power sources, such as variable power supplies, are rated at a fixed maximum load current and adjustable over a predetermined voltage range: i.e., 5-30V @ 20A. If the resistive load characteristic were used for this type of test, it would be necessary to reset the load each time the power supply voltage was changed, in order to maintain the full load current. However, if the load is set to the 100A constant current mode, a load of 20A is applied, then the power supply can be adjusted from 5-30V, and the load current will remain constant.

It should be noted that many power supplies are designed for short circuit protection by internal current limiting and bendback, and therefore, may not start up into a constant current type of load. Accordingly, the constant resistance characteristic should be used as a load when simulating short circuit protection and recovery of most power supplies, unless otherwise specified by the manufacturer.

3.3 Pulse Mode

The pulse load may be varied from 0-20A or from 0-200A peak current by the pulse amplitude control on the front panel. The frequency may be varied from approximately 200Hz to 20KHz by the frequency control on the front panel and the duty cycle of the square wave can be adjusted from 10% to 90% with the width control on the front panel. This pulse load may be superimposed on top of a constant DC load, which may be selected by the DC load control on the front panel.

If the pulse is to be used down to a no-load state,* the DC load controls should be turned fully counterclockwise. The maximum total of the pulse and DC load will be limited around 220A by the internal current limit protection.

*The pulse load is most effective with some steady state load current to which the pulse added. Pulsing from zero load creates a delay in the pulse rise and fall. The pulse current should be monitored on an oscilloscope to assure proper operation.

The rise time of the load current pulse is approximately 15 us for a 20-200A pulse and return. Operation at low voltages (less than 5V) may result in transient to less than 1V at the input terminal due to $L di/dt$ drops in the power leads. This in turn may cause pulse waveform distortion and the user should monitor the load current waveforms to assure proper operation.

The DC and pulse load may be mixed in any combination through the use of the separate DC load coarse and fine and the pulse load coarse and fine controls.

3.4 External Modulation

In the external modulation mode, the dynaload acts as a constant current load with the constant current proportional to the external voltage applied to J101.

The dynaload will program from 0-200A with a 0-10V @ 1 MA control signal. The input impedance of the external modulation terminals is approximately 10K ohms.

The linearity of the external program is set to be within $\pm 1\%$ above 2A.

The load may be pulsed or it will follow the programming waveform within the transient response limits of the Dynaload.

3.5 Power Rating

The model DLF 400-200-1500 will dissipate 1500W continuously. In order to assure that overheating does not occur, the rear and top of the Dynaload should be clear for the air intake and the air exhaust; i.e., the cooling air enters from the top and leaves from the rear. The dynaload should periodically be checked for dust accumulation.

3.6 Protective Circuits

The Dynaload has internal current limiting at approximately 220A maximum. In the event that an overvoltage is applied to the Dynaload, an internal overvoltage circuit will open the circuit breaker, thereby protecting all internal circuits.

The voltage current product (power) is also monitored to prevent an overpower condition from happening. Accordingly, the current limit characteristic is set to approximately 220A, which is maintained to approximately 6.8V. At this point, the current limit characteristic is reduced as the input voltage is increased, thereby limiting the maximum power which may be programmed into the Dynaload.

3.7 Special Applications

The Dynaload may be used for AC load testing, within its ratings, by the use of an external bridge rectifier, so that the Dynaload sees pulsating DC, but the AC source sees an AC load. The

effect of the rectifier is to slightly distort the Dynaload characteristics at low voltages and currents. The Dynaload is not normally recommended for testing AC sources above 1000 cycles unless the user specifically recognizes the load characteristics at higher frequencies.

3.8 Effects of Cable Inductance on Pulse Loading

When the Dynaload is used for high current pulse loading, the effects of cable inductance must be considered. A special 5 foot coaxial power cable is provided with the DLF to minimize wiring inductance and its use is strongly recommended. Other types of wiring or larger cables will limit speed of response and may cause ringing, etc.

The critical parameters are the 15 microsecond rise time and the 4.0V minimum compliance specifications. If the inductance of the cables from the voltage source to the dynaload is great enough to cause the voltage at the Dynaload to go below 4.0V, then excessive current wave form distortion will occur. This is because the power devices are driven into saturation in an attempt to reach the programmed current which cannot occur because of the low Drain voltage. Once in a saturated state, the response time is much slower. The result is a significant overshoot on the rising edge of the pulse.

The following is suggested to partially compensate for longer power leads:

1. 1 microhenry = 2.4 feet of wire (total).
2. 50A @ 15 microseconds rise time = 3.3 volt drop with 1 microhenry.
3. The inductive drop cannot exceed the difference between the source voltage and the 4.0V compliance.

For example: To test a 8.0v source with a 85A pulse, the maximum cable length would be:

$$E \text{ Max drop} = 4.0V$$

$$E = L(di/dt) \quad 4.0V = L(85A/15us)$$

$$L = 0.71 \text{ microhenries maximum}$$

$$\text{Maximum cable length} = 1.7 \text{ feet total}$$

Since this distance is relatively short, a low inductance cable is provided. This cable (5 feet long with an overall inductance of 5 uh) is compensated for internally by the load.

If the distance from the load to the source must be greater than this, there are several methods to increase the maximum distance. One way is to use several insulated conductors. This cuts the inductance in half if 4 are used instead of 2, or by

one-third if 6 are used. This doubles or triples the maximum length, respectively. If oscillations or ringing occur with longer cables, the unit may be stabilized by an electrolytic capacitor in series with a damping resistor across the terminals of the load.

4. CALIBRATION PROCEDURES (Refer to FIG. 1)

4.1 Current Sample calibrate

- A. Set current sample for 10.0V with Dynaload drawing 200A, adjust R5(CS CAL) on the A6 PC board.
- B. With the Dynaload drawing 20A set current sample for 1.0V, adjust R10(CS OFFSET) on A6.
- C. Repeat these two steps until no further adjustments are necessary.

4.2 Remote Programing Calibrate

- A. Set programming source to 10.0V adjust R1(REMOTE) on A1 so the Dynaload draws 200.0A
- B. Set program source for 1.0V and adjust R14(OFFSET) on A1 so the load draws 20.0A.
- C. Repeat steps A and B until no further adjustments are necessary. Check programming linearity at 1.0V intervals.

4.3 Voltmeter Calibrate

- A. Select the high range and apply 300V to the load inputs. Adjust R47(HV) on A4 so the voltmeter indicates the correct voltage.

- DLF 400-200-1500
- B. Select the low range and apply 100V to the load inputs. Adjust R45(LV) on A4 so the voltmeter indicates the correct voltage.

4.4 Ammeter Calibrate

- A. Select the high range and with the Dynaload drawing 200.0A adjust R42(HA) on A4 so the ammeter indicates the correct current.
- B. Select the low range and with the Dynaload drawing 15.0A adjust R40(LA) on A4 so the ammeter indicates the correct current.

4.5 Constant Current Calibrate

- A. Select the 20A constant current mode and turn the DC Load coarse adjust fully clockwise. Adjust R4(LCC) on A4 so the load draws 20.0A.
- B. Select the 200A constant current mode and turn the DC Load coarse adjust fully clockwise. Adjust R5(HCC) on A4 so the load draws 200.0A.

4.6 Constant Resistance Calibrate

- A. Select the 6A/V constant resistance mode, apply 10.0V to DC load inputs and turn the DC Load coarse adjust fully clockwise. Adjust R8(LA/V) on A4 until the load draws 60.0A.
- B. Select the 60A/V constant resistance mode, apply 3.0V to the DC load inputs and turn the DC Load coarse adjust fully clockwise. Adjust R9(HA/V) so the load draws 180.0A.

4.7 Current Limit Calibrate

Select the 60A/V constant resistance range and apply 4V to the load inputs. Increase the current to between 210 and 230 amps. Adjust R7(CL) on A1 until current limit is achieved and the OC alarm lights.

4.8 Power Limit Calibrate

Select the 0-20A constant current mode and apply 100V to the load inputs. Increase the current to 17A and adjust R10(CL) on A1 to limit the current between 15.2A and 17A at 100V input. Check that the PL alarm lights. Increase input voltage to 200V and the current should be limited between 7.6A and 8.5A.

4.9 Overvoltage Calibrate

Set overvoltage trip point between 410V and 440V by adjusting R24(OV) on A1. Check that the OV alarm lights.

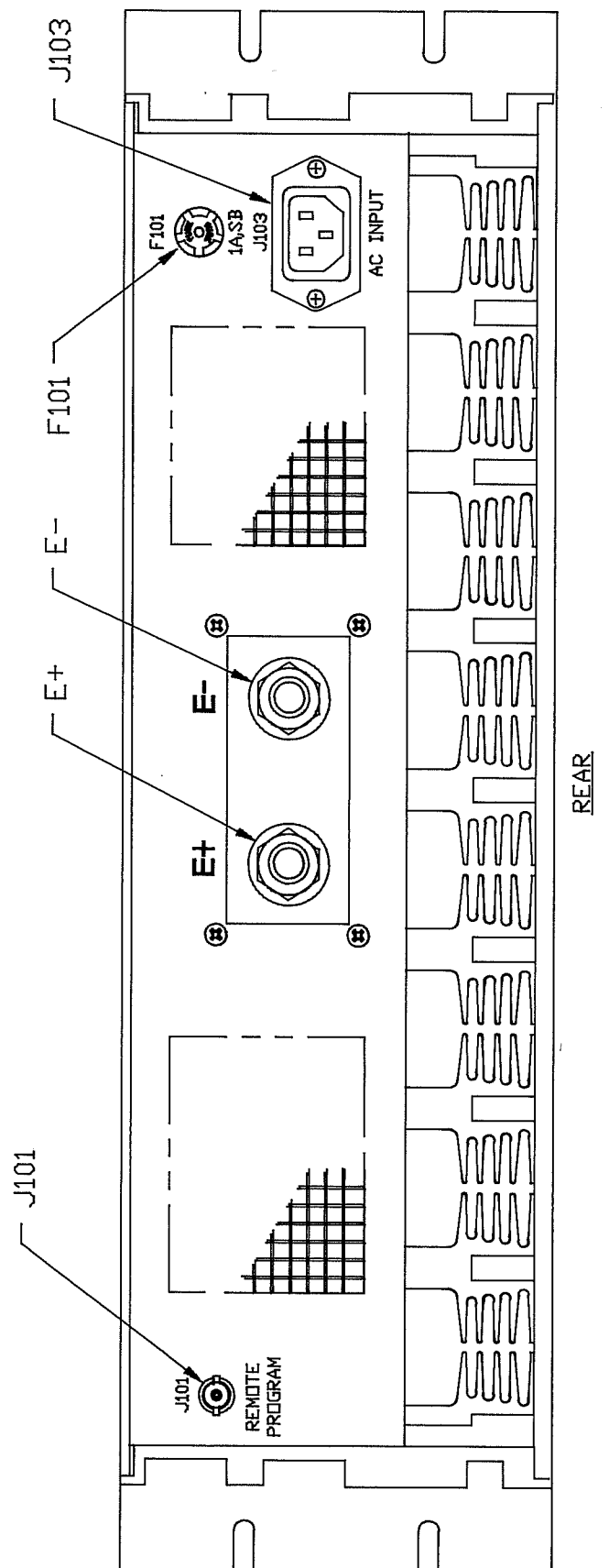
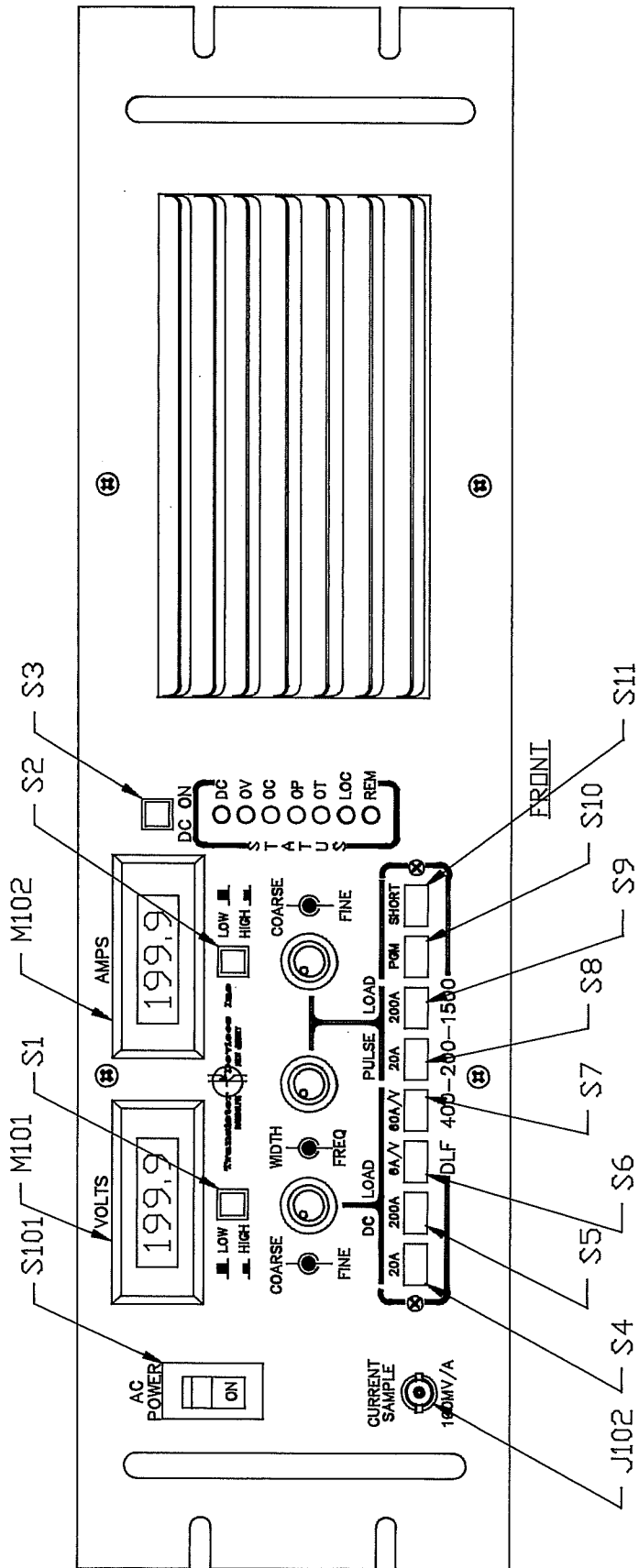

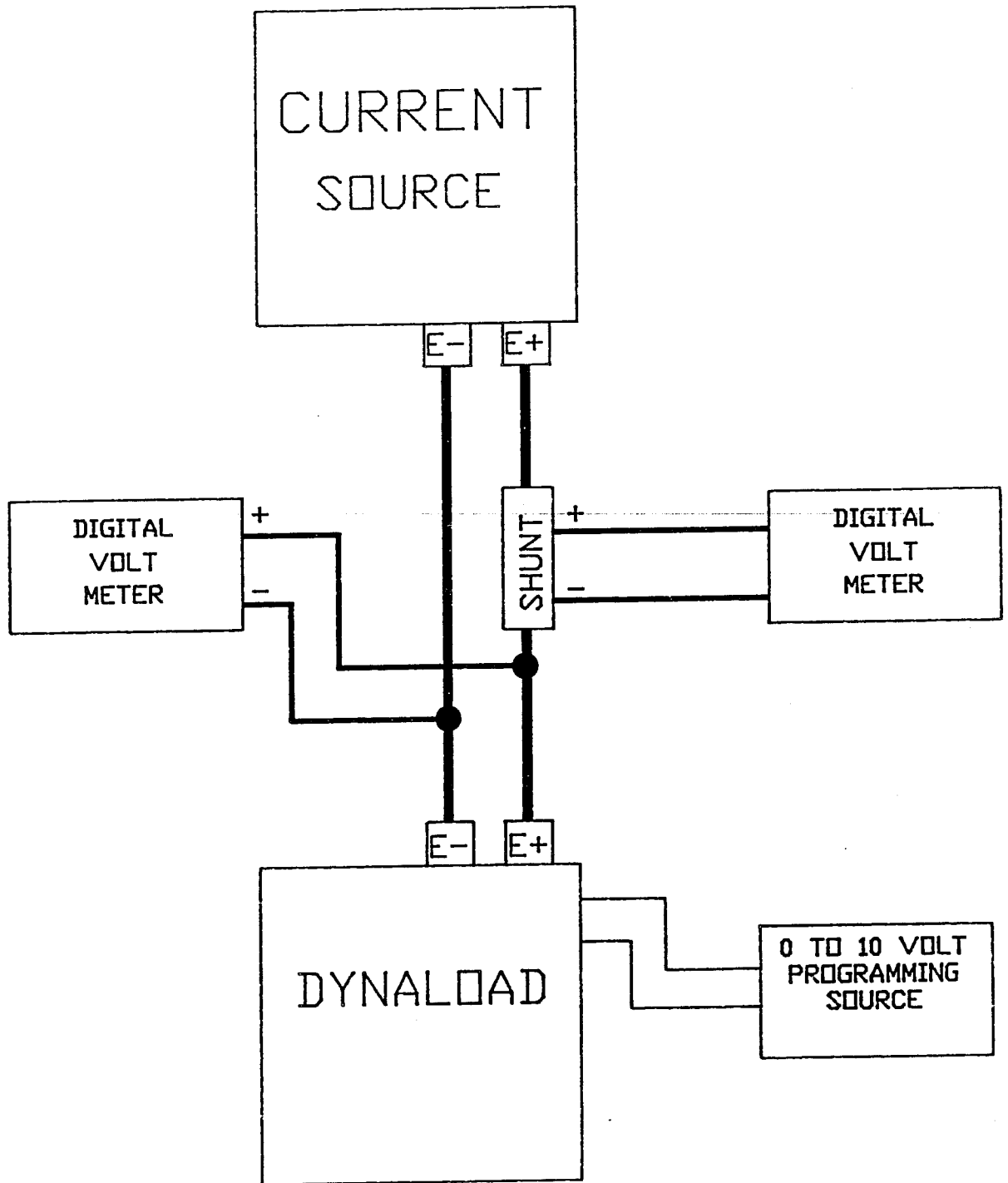

FIGURE 1. CALIBRATION SETUP

HIGH VOLTMETER ADJUST

LOW VOLTMETER ADJUST

LOW CONSTANT RESISTANCE ADJUST

HIGH CONSTANT RESISTANCE ADJUST

LOW CONSTANT CURRENT ADJUST

HIGH CONSTANT CURRENT ADJUST

HIGH AMMETER ADJUST

LOW AMMETER ADJUST

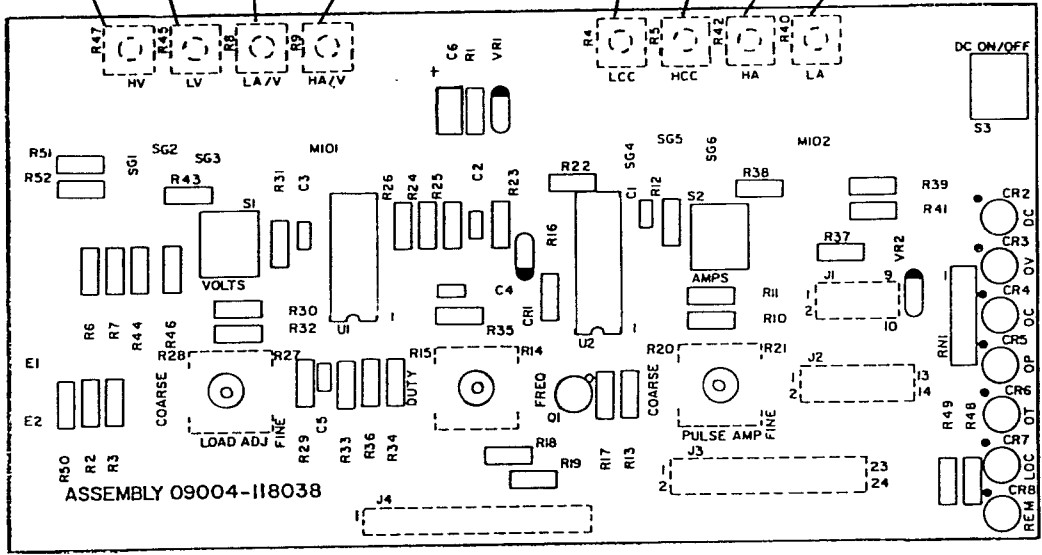

A4

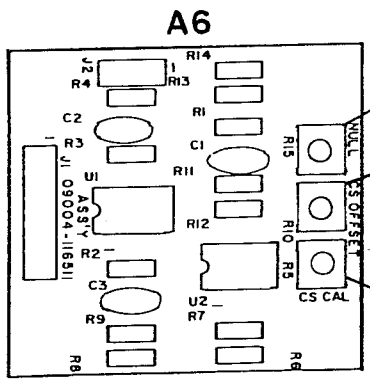

A6

NOT USED

CURRENT SAMPLE OFFSET

CURRENT SAMPLE CALIBRATION

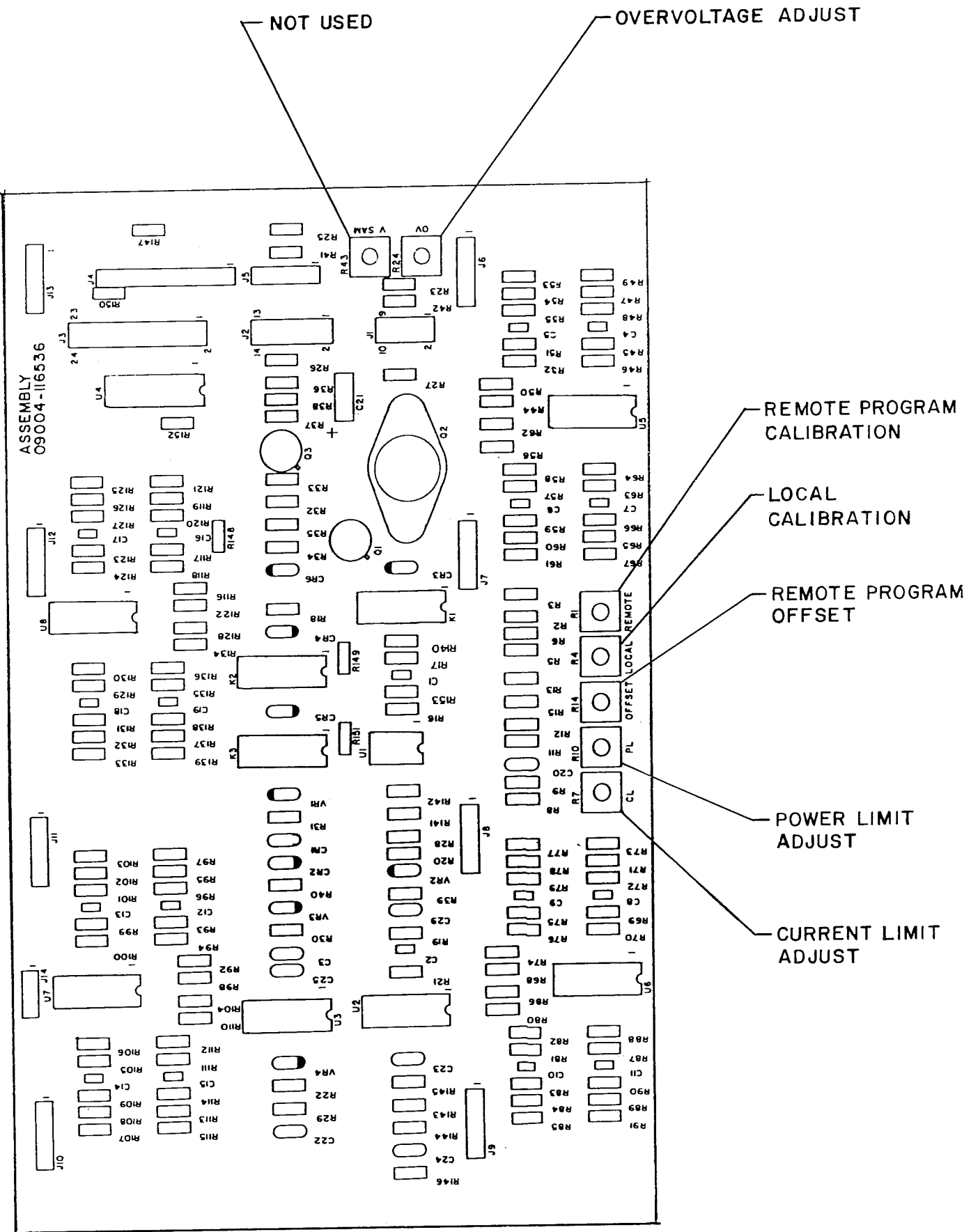

AI

REVISIONS		DATE	APP'D
ZONE/REV	DESCRIPTION		
A	REVISE & RELEASE TO PRODUCTION ERN 16599	7-15-91	

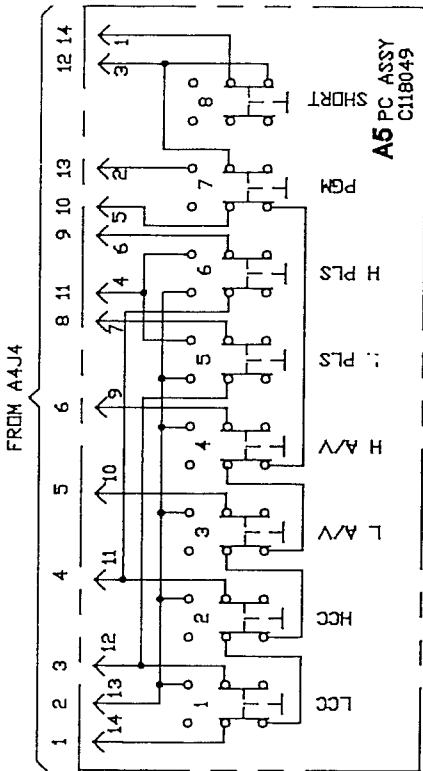

A5 SELECTOR SWITCH FUNCTION

SWITCH IDENT	MODEL NO.													
	DLF 100-100-750	DLF 400-100-750	DLF 100-200-1500	DLF 400-200-1500	DLF 100-600-4000	DLF 400-600-4000	DLF 600-5-750	DLF 600-5-1500						
LCC	10A	10A	20A	20A	60A	60A	.5A	.5A						
HCC	100A	100A	200A	200A	600A	600A	5A	5A						
LA/V	10A/V	30A/V	6A/V	6A/V	30A/V	12A/V	.01A/V	.01A/V						
HA/V	100A/V	300A/V	60A/V	60A/V	300A/V	120A/V	.10A/V	.10A/V						
L PLS	10A	10A	20A	20A	60A	60A	.5A	.5A						
H PLS	100A	100A	200A	200A	600A	600A	5A	5A						
PGM	PGM	PGM	PGM	PGM	PGM	PGM	PGM	PGM						
SHORT	SHORT	SHORT	SHORT	SHORT	SHORT	SHORT	SHORT	SHORT						

QTY	CODE IDENT NO.	PART NO OR IDENTIFYING NO.	DESCRIPTION OR NOMENCLATURE	FIND NO.

PARTS LIST

CENTR NO.		DRAWING TITLE	
DR	CROUSE	B	NOV 90
CHK			
A			
P			
P			
D			
APPROVED			
BY		DIRECTION OF	

Transistor Devices Inc
Randolph New Jersey

SCHEMATIC

FUNCTION SELECTOR SWITCH

SIZE	CODE IDENT NO.	DRAWING NO.	SHEET	OF
C	09004	121492		
SCALE	DLF/ASSELSW			

UNLESS OTHERWISE SPECIFIED DIMENSIONS ARE IN INCHES	
TOLERANCES	ANGLES *
FRACTIONS *	
3 PLACE DECIMALS *	
2 PLACE DECIMALS *	
1 PLACE DECIMALS *	
MATERIAL	
SPS3716	
SPS3715	
DLF 4000	
DLF 1500	
DLF 750	
NEXT ASSY	USED IN
APPLICATION	

ZONE/REV	REVISIONS	DATE	APPD
	DESCRIPTION		

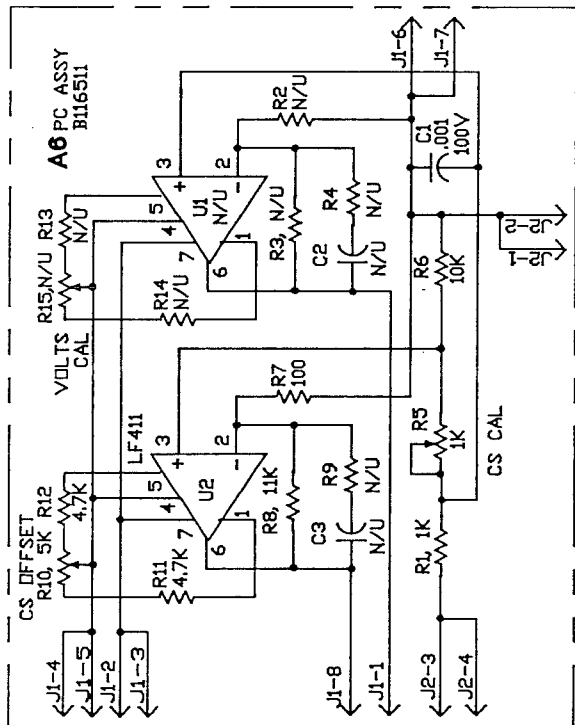

NOTES:

- UNLESS OTHERWISE SPECIFIED:
 ALL RESISTANCE VALUES ARE IN OHMS, 1/4W, 2%
 ALL CAPACITANCE VALUES ARE IN MICROFARADS

QTY REQD	CODE IDENT NO.	PART NO. OR IDENTIFYING NO.	NOMENCLATURE OR DESCRIPTION	FIND NO.
PARTS LIST				
CONTR NO.		Transistor Devices Inc Randolph New Jersey		
DR	CROUSE	17 AUG 90	DRAWING TITLE	
CHK			SCHEMATIC	
A			CURRENT SAMPLE AMPLIFIER	
P				
D				
APPROVED		SIZE	CODE IDENT NO.	DRAWING NO.
BY DIRECTION OF		C	09004	121493
		SCALE	DLF/SCHSAMP	SHEET OF

UNLESS OTHERWISE SPECIFIED DIMENSIONS ARE IN INCHES	
TOLERANCES ANGLES *	
FRACTIONS *	
3 PLACE DECIMALS *	
2 PLACE DECIMALS *	
1 PLACE DECIMALS *	
MATERIAL	
	DLF4000
	DLF1500
	DLF750
NEXT ASSY USED ON	
APPLICATION	

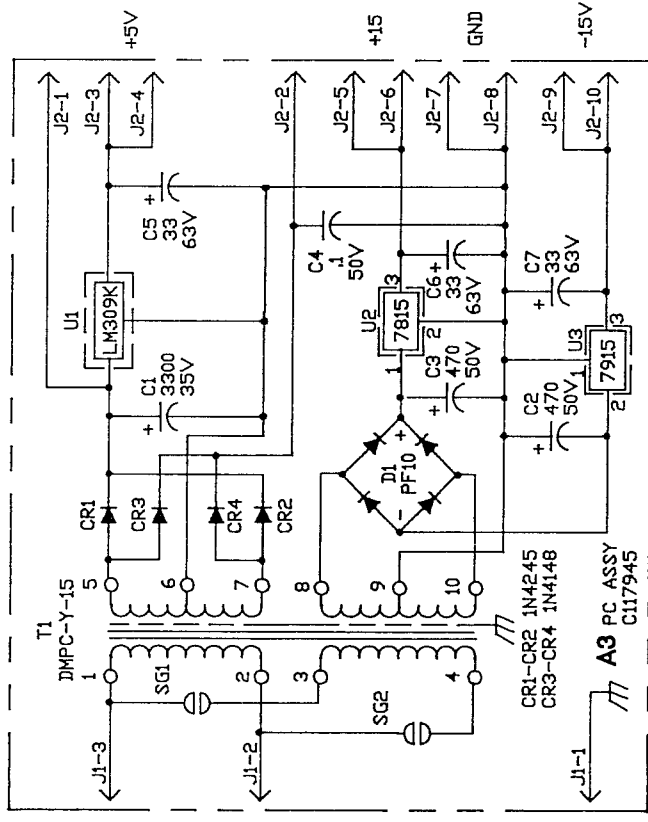

NOTES:
 1. UNLESS OTHERWISE SPECIFIED:
 ALL RESISTANCE VALUES ARE IN OHMS, 1/4W, 2%
 ALL CAPACITANCE VALUES ARE IN MICROFARADS

QTY RECD	CODE IDENT NO.	PART NO. OR IDENTIFYING NO.	MANUFACTURE OR DESCRIPTION	FIND NO.
			Transistor Devices Inc Rendolph, New Jersey	
PARTS LIST				
CONTR. NO.		DRAWING TITLE		
DR	CROUSE	B NOV 90	SCHEMATIC	
CHK			POWER SUPPLY	
A				
P				
D				
APPROVED		SIZE	CODE IDENT NO.	DRAWING NO.
BY		C	09004	121490
DIRECTION OF		SCALE	SHEET	
		DLF/PWRSUP1	OF	

UNLESS OTHERWISE SPECIFIED DIMENSIONS ARE IN INCHES	
TOLERANCES ANGLES *	
FRACTIONS *	
3 PLACE DECIMALS *	
2 PLACE DECIMALS *	
1 PLACE DECIMALS *	
MATERIAL	
SPS3716	
SPS3715	
DLF1500	
DLF750	
NEXT ASSY	USED ON
APPLICATION	

REVISIONS		DATE	APPD
ZONE/REV	DESCRIPTION		
A	REVISE & RELEASE TO PRODUCTION ERN 16599	7-15-91	PC
B	ADD DLF 400-200-4000 TO FUNCTION TABLE, ECN 17070	8-28-92	

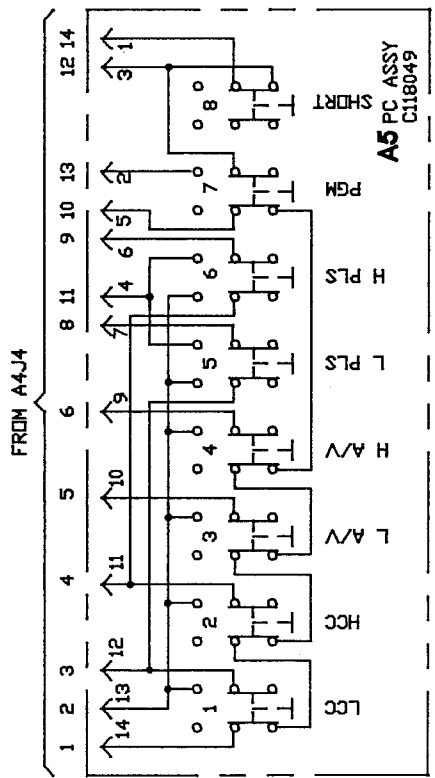

A5 SELECTOR SWITCH FUNCTION

SWITCH IDENT	MODEL NO.													
	DLF 100-100-750	DLF 100-100-1500	DLF 400-100-750	DLF 100-200-1500	DLF 400-200-1500	DLF 100-600-4000	DLF 400-600-4000	DLF 600-5-750	DLF 600-5-1500	DLF 400-200-4000	DLF 600-5-1500	DLF 400-200-4000	DLF 600-5-1500	DLF 400-200-4000
LCC	10A	20A	10A	20A	20A	60A	60A	.5A	.5A	20A	.5A	20A	.5A	20A
HCC	100A	200A	100A	200A	200A	600A	600A	5A	5A	200A	5A	200A	5A	200A
LA/V	10A/V	12A/V	3A/V	12A/V	6A/V	30A/V	12A/V	.01A/V	.01A/V	5A/V	.01A/V	5A/V	.01A/V	5A/V
HA/V	100A/V	120A/V	30A/V	120A/V	60A/V	300A/V	120A/V	.10A/V	.10A/V	50A/V	.10A/V	50A/V	.10A/V	50A/V
L PLS	10A	20A	10A	20A	20A	60A	60A	.5A	.5A	20A	.5A	20A	.5A	20A
H PLS	100A	200A	100A	200A	200A	600A	600A	5A	5A	200A	5A	200A	5A	200A
PGM	PGM	PGM	PGM	PGM	PGM	PGM	PGM	PGM	PGM	PGM	PGM	PGM	PGM	PGM
SHORT	SHORT	SHORT	SHORT	SHORT	SHORT	SHORT	SHORT	SHORT	SHORT	SHORT	SHORT	SHORT	SHORT	SHORT

QTY	CODE	DESCRIPTION	NUMERICAL OR	UNIT
REQD	IDENT NO.	IDENTIFYING NO.	DESCRIPTION	NO.

PARTS LIST	
CONTR NO.	TRANSISTOR DEVICES INC
DR	CROUSE B NOV 90
CHK	
A	
P	
B	
APPROVED	
BY	DIRECTION OF

UNLESS OTHERWISE SPECIFIED DIMENSIONS ARE IN INCHES	
TOLERANCES ANGLES *	
FRACTIONS *	
3 PLACE DECIMALS *	
2 PLACE DECIMALS *	
1 PLACE DECIMALS *	
MATERIAL	
SPS3716	
SPS3715	
DLF 4000	
DLF 1500	
DLF 750	
NEXT ASSY	USED IN
APPLICATION	

SCHEMATIC

FUNCTION SELECTOR SWITCH

CODE IDENT NO. DRAWING NO.

09004 121492

SCALE

DLF/ASSELSV

SHEET OF