Reference

EMI Receiver Series

HP 8542E/HP 8546A
EMI Receiver

HP 85422E/HP 85462A
Receiver RF Section



HP Part No. 5962-0491
Printed in USA January 1999

Notice

The information contained in this document is subject to change without notice.

Hewlett-Packard makes no warranty of any kind with regard to this material, including but not limited to, the implied warranties of merchantability and fitness for a particular purpose. Hewlett-Packard shall not be liable for errors contained herein or for incidental or consequential damages in connection with the furnishing, performance, or use of this material.

Certification

Hewlett-Packard Company certifies that this product met its published specifications at the time of shipment from the factory. Hewlett-Packard further certifies that its calibration measurements are traceable to the United States National Institute of Standards and Technology, to the extent allowed by the Institute's calibration facility, and to the calibration facilities of other International Standards Organization members.

Regulatory Information

Regulatory information is located in the *EMI Receiver Series Reference* at the end of Chapter 1, "Specifications and Characteristics."

Warranty

This Hewlett-Packard instrument product is warranted against defects in material and workmanship for a period of one year from date of shipment. During the warranty period, Hewlett-Packard Company will, at its option, either repair or replace products which prove to be defective.

For warranty service or repair, this product must be returned to a service facility designated by Hewlett-Packard. Buyer shall prepay shipping charges to Hewlett-Packard and Hewlett-Packard shall pay shipping charges to return the product to Buyer. However, Buyer shall pay all shipping charges, duties, and taxes for products returned to Hewlett-Packard from another country.

Hewlett-Packard warrants that its software and firmware designated by Hewlett-Packard for use with an instrument will execute its programming instructions when properly installed on that instrument. Hewlett-Packard does not warrant that the operation of the instrument, or software, or firmware will be uninterrupted or error-free.

LIMITATION OF WARRANTY

The foregoing warranty shall not apply to defects resulting from improper or inadequate maintenance by Buyer, Buyer-supplied software or interfacing, unauthorized modification or misuse, operation outside of the environmental specifications for the product, or improper site preparation or maintenance.

NO OTHER WARRANTY IS EXPRESSED OR IMPLIED. HEWLETT-PACKARD SPECIFICALLY DISCLAIMS THE IMPLIED WARRANTIES OF MERCHANTABILITY AND FITNESS FOR A PARTICULAR PURPOSE.

EXCLUSIVE REMEDIES

THE REMEDIES PROVIDED HEREIN ARE BUYER'S SOLE AND EXCLUSIVE REMEDIES. HEWLETT-PACKARD SHALL NOT BE LIABLE FOR ANY DIRECT, INDIRECT, SPECIAL, INCIDENTAL, OR CONSEQUENTIAL DAMAGES, WHETHER BASED ON CONTRACT, TORT, OR ANY OTHER LEGAL THEORY.

Assistance

Product maintenance agreements and other customer assistance agreements are available for Hewlett-Packard products. For any assistance, contact your nearest Hewlett-Packard Sales and Service Office.

Compliance

This instrument has been designed and tested in accordance with IEC Publication 348, Safety Requirements for Electronic Measuring Apparatus, and has been supplied in a safe condition. The instruction documentation contains information and warnings which must be followed by the user to ensure safe operation and to maintain the instrument in a safe condition.

Safety Notes

The following safety notes are used throughout this manual. Familiarize yourself with each of the notes and its meaning before operating this instrument.

WARNING

Warning denotes a hazard. It calls attention to a procedure which, if not correctly performed or adhered to, could result in injury or loss of life. Do *not* proceed beyond a warning note until the indicated conditions are fully understood and met.

CAUTION

Caution denotes a hazard. It calls attention to a procedure that, if not correctly performed or adhered to, would result in damage to or destruction of the instrument. Do *not* proceed beyond a caution sign until the indicated conditions are fully understood and met.

General Safety Considerations

WARNING

- No operator serviceable parts inside. Refer servicing to qualified personnel. To prevent electrical shock, do not remove covers.
- If this instrument is used in a manner not specified by Hewlett-Packard Company, the protection provided by the instrument may be impaired.
- For continued protection against fire hazard, replace line fuse only with same type and rating ([F 5A/250V]). The use of other fuses or material is prohibited.

CAUTION

- Before switching on this instrument, make sure that the line voltage selector switch is set to the voltage of the power supply and the correct fuse is installed.
- Always use the three-prong ac power cord supplied with this instrument. Failure to ensure adequate earth grounding by not using this cord may cause instrument damage.



The instruction documentation symbol. The product is marked with this symbol when it is necessary for the user to refer to the instructions in the documentation.

CE

The CE mark is a registered trademark of the European Community. (If accompanied by a year, it is when the design was proven.)

ISM1-A

This is a symbol of an Industrial Scientific and Medical Group 1 Class A product.

CSA

The CSA mark is a registered trademark of the Canadian Standards Association.

Manual Conventions

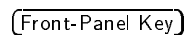
 Front-Panel Key

This represents a key physically located on the instrument.

 Softkey

This indicates a “softkey,” a key whose label is determined by the firmware of the instrument.

Screen Text

This indicates text displayed on the instrument’s screen.

EMI Receiver Series Documentation Description

The following documents are provided with either the HP 8542E/HP 8546A EMI receiver or the HP 85422E/HP 85462A receiver RF section.

- *Installation and Verification* provides information for installing your instrument, verifying instrument operation, and customer support.
- *User's Guide* describes instrument features and how to make measurements with your EMI receiver or receiver RF section.
- *Reference* provides specifications and characteristics, menu maps, error messages, and key descriptions.
- *Programmer's Guide* provides information on remote control instrument configuration, creating programs, and parameters for each of the programming commands available.

Contents

| | |
|--|------|
| 1. HP 8542E/HP 85422E Specifications and Characteristics | |
| Definitions of Terms | 1-1 |
| General Specifications: HP 8542E EMI Receiver | 1-2 |
| General Specifications: HP 8542E EMI Receiver (continued) | 1-3 |
| General Specifications: HP 8542E EMI Receiver (continued) | 1-4 |
| Tuning Specifications | 1-5 |
| Swept Frequency Specifications | 1-6 |
| Amplitude Specifications | 1-7 |
| Amplitude Specifications (continued) | 1-8 |
| Amplitude Specifications (continued) | 1-9 |
| Amplitude Specifications (continued) | 1-10 |
| Amplitude Specifications (continued) | 1-11 |
| Amplitude Specifications (continued) | 1-12 |
| Tracking Generator Specifications | 1-13 |
| Frequency Characteristics | 1-14 |
| Amplitude Characteristics | 1-15 |
| Tracking Generator Characteristics | 1-16 |
| Physical Characteristics | 1-17 |
| Physical Characteristics (continued) | 1-18 |
| General Specifications: HP 85422E Receiver RF Section | 1-20 |
| General Specifications: HP 85422E Receiver RF Section (continued) | 1-21 |
| Tuning Specifications | 1-22 |
| Swept Frequency Specifications | 1-23 |
| Amplitude Specifications | 1-24 |
| Amplitude Specifications (continued) | 1-25 |
| Amplitude Specifications (continued) | 1-26 |
| Amplitude Specifications (continued) | 1-27 |
| Tracking Generator Specifications | 1-28 |
| Tracking Generator Specifications (continued) | 1-29 |
| Frequency Characteristics | 1-30 |
| Amplitude Characteristics | 1-31 |
| Amplitude Characteristics (continued) | 1-32 |
| Tracking Generator Characteristics | 1-33 |
| Physical Characteristics | 1-34 |
| Physical Characteristics (continued) | 1-35 |
| Regulatory Information | 1-37 |
| Notice for Germany: Noise Declaration | 1-39 |

| | |
|--|------|
| 2. HP 8546A/HP 85462A Specifications and Characteristics | |
| Definitions of Terms | 2-1 |
| General Specifications: HP 8546A EMI Receiver | 2-2 |
| General Specifications: HP 8546A EMI Receiver (continued) | 2-3 |
| General Specifications: HP 8546A EMI Receiver (continued) | 2-4 |
| Tuning Specifications | 2-5 |
| Swept Frequency Specifications | 2-6 |
| Amplitude Specifications | 2-7 |
| Amplitude Specifications (continued) | 2-8 |
| Amplitude Specifications (continued) | 2-9 |
| Amplitude Specifications (continued) | 2-10 |
| Amplitude Specifications (continued) | 2-11 |
| Amplitude Specifications (continued) | 2-12 |
| Tracking Generator Specifications | 2-13 |
| Frequency Characteristics | 2-14 |
| Amplitude Characteristics | 2-15 |
| Tracking Generator Characteristics | 2-16 |
| Physical Characteristics | 2-17 |
| Physical Characteristics (continued) | 2-18 |
| General Specifications: HP 85462A Receiver RF Section | 2-20 |
| General Specifications: HP 85462A Receiver RF Section (continued) | 2-21 |
| Tuning Specifications | 2-22 |
| Swept Frequency Specifications | 2-23 |
| Amplitude Specifications | 2-24 |
| Amplitude Specifications (continued) | 2-25 |
| Amplitude Specifications (continued) | 2-26 |
| Amplitude Specifications (continued) | 2-27 |
| Tracking Generator Specifications | 2-29 |
| Tracking Generator Specifications (continued) | 2-30 |
| Frequency Characteristics | 2-31 |
| Amplitude Characteristics | 2-32 |
| Amplitude Characteristics (continued) | 2-33 |
| Tracking Generator Characteristics | 2-34 |
| Physical Characteristics | 2-35 |
| Physical Characteristics (continued) | 2-36 |
| Regulatory Information | 2-38 |
| Notice for Germany: Noise Declaration | 2-40 |
| | |
| 3. Key Menus | |
| User Defined Keys | 3-1 |
| | |
| 4. Key Dictionary Reference | |
| Service Functions | 4-2 |
| Service Calibration Functions | 4-2 |
| Service Diagnostic Functions | 4-2 |
| Key Functions | 4-4 |
| % AM | 4-4 |
| ϕ LOCKON OFF | 4-4 |
| μA/m | 4-5 |
| μV/m | 4-5 |

| | |
|-------------------|------|
| 0-2.9 Gz BAND 0 | 4-5 |
| 2v REF DETECTOR | 4-6 |
| 2.75-6.5 BAND 1 | 4-6 |
| 3 dB POINTS | 4-7 |
| 3rd ORD MEAS | 4-7 |
| 6 dB POINTS | 4-8 |
| 9 kHz - 150 kHz | 4-8 |
| 9 kHz EMI BW | 4-8 |
| +10V REF DETECTOR | 4-9 |
| -10V REF DETECTOR | 4-9 |
| 30 MHz - 300 MHz | 4-9 |
| 99% PWR BW | 4-10 |
| 120 kHz EMI BW | 4-10 |
| 150 kHz - 30 MHz | 4-10 |
| 200 Hz EMI BW | 4-11 |
| 200 MHz - 1 GHz | 4-11 |
| A<-->B | 4-11 |
| A-B -> A ON OFF | 4-12 |
| A -> C | 4-12 |
| ABCDEF | 4-13 |
| ABORT | 4-13 |
| ACTIVE | 4-13 |
| ADD TO LIST | 4-13 |
| Adjust Color | 4-14 |
| ADVISORY | 4-14 |
| ALC INT EXT | 4-14 |
| AMPL SCL LOG LIN | 4-15 |
| AMPLITUDE | 4-15 |
| Amptd Units | 4-16 |
| ANNOTATN | 4-16 |
| ANNOTATN ON OFF | 4-16 |
| ANTENNA -> DISK | 4-17 |
| Antenna Factors | 4-17 |
| ANTENNA ON OFF | 4-17 |
| Antenna Units | 4-18 |
| APND CAT ITEM | 4-18 |
| ATTEN AUTO MAN | 4-18 |
| AUTO ALL | 4-19 |
| AUTO CAL ON OFF | 4-19 |
| AUTO COUPLE | 4-20 |
| AUTO-MEASURE | 4-20 |

| | |
|------------------|------|
| AUTO RANGE | 4-21 |
| AUTOEXEC ON OFF | 4-21 |
| AUTORANG ON OFF | 4-21 |
| Aux Conn Control | 4-22 |
| AUX CTRL | 4-22 |
| AV DWELL TIME | 4-22 |
| AVERAGE | 4-23 |
| AVG BW AUTO MAN | 4-23 |
| AV/IF BW RATIO | 4-23 |
| B -> C | 4-24 |
| B <--> C | 4-24 |
| B-DL -> B | 4-24 |
| BACKGRND | 4-24 |
| Band Lock | 4-25 |
| BAUD RATE | 4-25 |
| BLACK FILL | 4-26 |
| BLACK LEVEL | 4-26 |
| BLANK A | 4-26 |
| BLANK B | 4-27 |
| BLANK C | 4-27 |
| BLUE | 4-27 |
| BLUE FILL | 4-27 |
| BND LOCK ON OFF | 4-28 |
| BRIGHT | 4-28 |
| BW | 4-29 |
| CABLE -> DISK | 4-29 |
| Cable Factors | 4-29 |
| CABLE ON OFF | 4-30 |
| CAL 85422 | 4-30 |
| CAL 85462 | 4-30 |
| CAL ALL | 4-30 |
| CAL AMP | 4-31 |
| Cal At Time | 4-31 |
| CAL CHECK | 4-31 |
| CAL FETCH | 4-31 |
| CAL FREQ | 4-32 |
| CALIBRATE | 4-32 |
| CAL INPUT 1 | 4-32 |
| CAL INPUT 2 | 4-32 |
| CAL MXR | 4-33 |
| CAL STORE | 4-33 |
| CAL TIMEBASE | 4-33 |

| | |
|-----------------------------|------|
| CAL TRK GEN | 4-34 |
| CAL YTF | 4-34 |
| CATALOG ALL | 4-34 |
| CATALOG DISK | 4-35 |
| Catalog Internal | 4-35 |
| CATALOG PREFIX | 4-37 |
| CATALOG REGISTER | 4-37 |
| CATALOG VARIABLES | 4-38 |
| CENTER FREQ | 4-38 |
| CF STEP AUTO MAN | 4-38 |
| Change Prefix | 4-39 |
| Change Title | 4-40 |
| CLEAR ANNOTATN | 4-41 |
| CLEAR MARK | 4-41 |
| CLEAR WRITE A | 4-41 |
| CLEAR WRITE B | 4-42 |
| CLEAR WRITE C | 4-43 |
| CLR ALL MARKS | 4-43 |
| CNTL A O 1 | 4-44 |
| CNTL B O 1 | 4-44 |
| CNTL C O 1 | 4-44 |
| CNTL D O 1 | 4-45 |
| COARSE TUNE DAC | 4-45 |
| COLOR BARS | 4-45 |
| COLOR MONOCHRM | 4-46 |
| COMPLMNT MARKS | 4-46 |
| CONFIG | 4-46 |
| CONFIG DONE | 4-47 |
| COPY | 4-47 |
| COPY DEV PRNT PLT | 4-49 |
| COPY SCREEN | 4-50 |
| CORRECT ON OFF | 4-50 |
| Correctn Factors | 4-50 |
| CORRECTN ON OFF | 4-51 |
| COUPLE AC DC | 4-51 |
| CNT RES AUTO MAN | 4-51 |
| CTRL | 4-52 |
| DACS | 4-53 |
| DATEMODE MDY DMY | 4-53 |
| dBm | 4-53 |
| dBmV | 4-54 |

| | |
|-----------------------------|------|
| dB μ V | 4-54 |
| DEFAULT CAL DATA | 4-54 |
| DEFAULT COLORS | 4-55 |
| DEFAULT CONFIG | 4-55 |
| Define List | 4-56 |
| Define Report | 4-56 |
| DEFINE USER KEY | 4-56 |
| DELETE ALL SIGS | 4-57 |
| DELETE FACTORS | 4-57 |
| DELETE FILE | 4-57 |
| DELETE LIMIT | 4-59 |
| DELETE MARKED | 4-59 |
| DELETE POINT | 4-59 |
| DELETE SEGMENT | 4-60 |
| DELETE SIGNAL | 4-60 |
| Delete Signals | 4-61 |
| DELTA MEAS | 4-61 |
| DEMOD AM FM | 4-61 |
| DEMOD ON OFF | 4-62 |
| DESKJET | 4-62 |
| DESKJET 500 | 4-62 |
| DESKJET 500C | 4-63 |
| DESKJET 550C | 4-63 |
| DETECTOR PK QP AV | 4-63 |
| DETECTOR SMP PK | 4-64 |
| Disk Config | 4-64 |
| DISPLAY | 4-64 |
| DISPLAY -> DISK | 4-65 |
| DISPLAY CAL DATA | 4-65 |
| DISPLAY CNTL I | 4-65 |
| Display Config | 4-66 |
| Display Sys Data | 4-66 |
| DISPOSE USER KEY | 4-66 |
| Dispose User Mem | 4-66 |
| DROOP | 4-67 |
| DSP LINE ON OFF | 4-67 |
| DWELL TIME | 4-68 |
| EDIT ANNOTATN | 4-68 |
| EDIT ANTENNA | 4-68 |
| EDIT CABLE | 4-69 |

| | |
|----------------------------|------|
| EDIT CAT ITEM | 4-69 |
| Edit Colors | 4-69 |
| EDIT DONE | 4-70 |
| EDIT FLATNESS | 4-71 |
| EDIT LAST | 4-71 |
| Edit Limit | 4-72 |
| EDIT LIMIT | 4-72 |
| EDIT LIST | 4-72 |
| EDIT LOWER | 4-73 |
| EDIT MID/DELT | 4-73 |
| EDIT OTHER | 4-74 |
| EDIT PA FLTNESS | 4-74 |
| EDIT UP/LOW | 4-74 |
| EDIT UPPER | 4-75 |
| EDIT UPR LWR | 4-75 |
| Editor | 4-76 |
| EMI RECEIVER | 4-76 |
| EPSON MX | 4-77 |
| ERASE STATEALL | 4-77 |
| ERASE TRACEALL | 4-77 |
| ERRORS | 4-77 |
| EXECUTE TITLE | 4-78 |
| EXIT | 4-78 |
| EXIT CATALOG | 4-78 |
| EXIT EDIT | 4-79 |
| EXIT GRAPH | 4-79 |
| EXIT LAST CAL | 4-80 |
| EXIT MEASURE | 4-80 |
| EXIT SHOW | 4-80 |
| EXTERNAL | 4-81 |
| EXTERNAL PREAMPG | 4-81 |
| FAST STP ON OFF | 4-81 |
| FFT MEAS | 4-82 |
| FINE TUNE DAC | 4-82 |
| FLAT | 4-83 |
| Flatness Data | 4-83 |
| FM COIL DRIVE | 4-84 |
| FM GAIN | 4-84 |
| FM OFFSET | 4-84 |
| FM SPAN | 4-85 |

| | |
|-----------------------------|------|
| FORMAT DOS DISK | 4-85 |
| FORMAT LIF DISK | 4-85 |
| FREE RUN | 4-86 |
| FREQ DIAG | 4-86 |
| FRQ DISC NORM OFF | 4-86 |
| FREQ OFFSET | 4-87 |
| FREQ SCL LOG LIN | 4-87 |
| FREQ STEP | 4-88 |
| FREQUENCY | 4-88 |
| FRQ SCAN ON OFF | 4-89 |
| FULL SPAN | 4-89 |
| FULL WHITE | 4-89 |
| Gauss | 4-90 |
| GEO DST TEST | 4-90 |
| GHIJKL | 4-90 |
| GND REF DETECTOR | 4-90 |
| GRAT ON OFF | 4-91 |
| GRATICUL | 4-91 |
| GRAY SCALE | 4-91 |
| GREEN | 4-92 |
| GREEN FILL | 4-92 |
| GRID | 4-92 |
| HALF FILL | 4-93 |
| HI VOLT TEST | 4-93 |
| HOLD | 4-93 |
| HORIZ LINES | 4-93 |
| HSL RGB | 4-94 |
| HUE | 4-94 |
| IDNUM | 4-94 |
| IF BW AUTO MAN | 4-95 |
| IF GAINS | 4-95 |
| INIT FLT | 4-95 |
| INPT LCK ON OFF | 4-96 |
| INPUT | 4-96 |
| Input | 4-96 |
| INPUT 1 | 4-96 |
| INPUT 1 9k-50M | 4-97 |
| INPUT 1 PREAMP | 4-97 |
| INPUT 2 | 4-97 |
| INPUT 2 20M-2.9G | 4-97 |
| INPUT 2 1-6.5G | 4-98 |

| | |
|-----------------------------|-------|
| INPUT 2 BYPASS | 4-98 |
| INPUT 2 PREAMP | 4-98 |
| INPUT Z 50Ω 75Ω | 4-99 |
| Inst Setup | 4-99 |
| INTENSITY | 4-99 |
| INTERNAL -> STATE | 4-100 |
| Internal -> Trace | 4-100 |
| LASERJET | 4-101 |
| LASERJET II | 4-101 |
| LASERJET III | 4-101 |
| Last Cal | 4-101 |
| Last Hrd Key Menu | 4-102 |
| LAST SPAN | 4-102 |
| Limit 1 | 4-102 |
| LIMIT 1 ON OFF | 4-103 |
| Limit 2 | 4-103 |
| LIMIT 2 ON OFF | 4-103 |
| LIMIT LINE 1 | 4-104 |
| Limit Lines | 4-104 |
| LIMIT LINES | 4-104 |
| LIMITS -> DISK | 4-105 |
| LIMITS FIX REL | 4-105 |
| LIMITS FRQ TIME | 4-106 |
| LINE | 4-107 |
| LINEARITY | 4-107 |
| LINEARITY CHECK | 4-107 |
| LIN ON OFF | 4-107 |
| LIST -> DISK | 4-108 |
| LIST ON OFF | 4-108 |
| LMT DISP Y N AUTO | 4-108 |
| LMT TEST ON OFF | 4-109 |
| LOAD FILE | 4-109 |
| (LOCAL) | 4-110 |
| LOG ON OFF | 4-111 |
| LOGF SPD STD FAST | 4-111 |
| LUMIN-OSITY | 4-111 |
| MAIN COIL DR | 4-112 |
| MAIN SPAN | 4-112 |
| MAN TRK ADJUST | 4-112 |
| MARGIN 1 ON OFF | 4-113 |
| MARGIN 2 ON OFF | 4-113 |

| | |
|-------------------|-------|
| MARK ALL DUPLICAT | 4-113 |
| MARK ALL SIGNALS | 4-114 |
| MARK LWR DUPLICAT | 4-114 |
| MARK SIGNAL | 4-114 |
| MARK TO END | 4-114 |
| MARKER | 4-115 |
| MARKER Δ | 4-115 |
| MARKER ΔSPAN | 4-116 |
| MARKER ->CF | 4-116 |
| MARKER ->CF STEP | 4-116 |
| MARKER-> MINIMUM | 4-117 |
| MARKER ->PK-PK | 4-117 |
| MARKER ->REF LVL | 4-117 |
| MARKER ->START | 4-118 |
| MARKER ->STOP | 4-118 |
| MARKER 1 ON OFF | 4-118 |
| MARKER 2 ON OFF | 4-118 |
| MARKER 3 ON OFF | 4-119 |
| MARKER 4 ON OFF | 4-119 |
| MARKER ALL OFF | 4-119 |
| MARKER AMPTD | 4-120 |
| MARKER FUNCTION | 4-120 |
| MARKER NORMAL | 4-120 |
| MARKERS | 4-121 |
| MARKER TUNE SPN | 4-121 |
| MAX HOLD A | 4-122 |
| MAX HOLD B | 4-122 |
| MAX MXR LVL | 4-122 |
| MEAS SNG CONT | 4-123 |
| MEAS STEPPED | 4-123 |
| MEAS/USER | 4-123 |
| MEASURE AT MKR | 4-124 |
| Measure Detector | 4-124 |
| MEM LOCKED | 4-124 |
| MIN HOLD C | 4-125 |
| MIXER BIAS DAC | 4-125 |
| MK COUNT ON OFF | 4-125 |
| MK NOISE ON OFF | 4-126 |
| MK PAUSE ON OFF | 4-126 |
| MKR | 4-126 |
| MKR -> | 4-127 |

| | |
|-------------------|-------|
| MK READ F T I P | 4-127 |
| MK TRACE AUTO ABC | 4-127 |
| MK TRACK ON OFF | 4-128 |
| MNOPQR | 4-128 |
| MODE | 4-129 |
| MONO-CHROME | 4-129 |
| NEW EDIT | 4-129 |
| NEXT | 4-130 |
| NEXT PAGE | 4-130 |
| NEXT PEAK | 4-130 |
| NEXT PK LEFT | 4-130 |
| NEXT PK RIGHT | 4-131 |
| NO CONVERSN | 4-131 |
| No User Menus | 4-131 |
| NORMLIZE ON OFF | 4-132 |
| NORMLIZE POSITION | 4-132 |
| ON/OFF | 4-132 |
| OPTICAL FILTER | 4-133 |
| OTHER -> DISK | 4-133 |
| Other Factors | 4-133 |
| OTHER ON OFF | 4-134 |
| OUTPUT | 4-134 |
| OUTPUT REPORT | 4-134 |
| OVLN ON OFF | 4-134 |
| PAINTJET | 4-135 |
| PALETTE BARS | 4-135 |
| PEAK EXCURSN | 4-135 |
| Peak Menu | 4-136 |
| PEAK SEARCH | 4-136 |
| PK DWELL TIME | 4-136 |
| PK-PK MEAS | 4-137 |
| Plot Config | 4-137 |
| PLOTTER ADDRESS | 4-137 |
| PLT MENU ON OFF | 4-138 |
| PLTS/PG 1 2 4 | 4-138 |
| POINT | 4-138 |
| POWER ON IP LAST | 4-139 |
| PREAMP | 4-140 |
| PREAMP ON OFF | 4-140 |
| PRESEL DAC | 4-141 |
| PRESEL DEFAULT | 4-141 |
| PRESEL PEAK | 4-141 |

| | |
|------------------|-------|
| PRESET | 4-142 |
| PRESET RECEIVER | 4-145 |
| PRESET SPECTRUM | 4-146 |
| Print Config | 4-148 |
| Print Options | 4-148 |
| PRINTER ADDRESS | 4-148 |
| PRINTER SETUP | 4-148 |
| Printer Type | 4-149 |
| PROTECT ON OFF | 4-149 |
| PRN/PAGE 1 2 | 4-149 |
| PRT MENU ON OFF | 4-150 |
| pTesla | 4-150 |
| PURGE LIMITS | 4-150 |
| PWR SWP ON OFF | 4-151 |
| QP/AVG 10X OFF | 4-152 |
| QP DET ON OFF | 4-152 |
| QP DWELL TIME | 4-152 |
| QP GAIN ON OFF | 4-153 |
| QPD OFFSET | 4-153 |
| QPD RST ON OFF | 4-153 |
| QUASI-PEAK | 4-154 |
| QUIETJET | 4-154 |
| RECALL | 4-154 |
| RECALL ANTENNA | 4-154 |
| RECALL CABLE | 4-155 |
| RECALL COLORS | 4-155 |
| Recall Disk | 4-155 |
| Recall Internal | 4-156 |
| RECALL LIMITS | 4-156 |
| RECALL LIST | 4-156 |
| RECALL OTHER | 4-157 |
| RECALL SETUP | 4-157 |
| RECALL TRACE | 4-157 |
| RECEIVER ADDRESS | 4-158 |
| RED | 4-158 |
| RED FILL | 4-158 |
| REF LVL | 4-158 |
| REF LVL OFFSET | 4-159 |
| REMEAS ALL SIGS | 4-159 |
| REMEAS MARKED | 4-160 |
| REMEAS SIGNAL | 4-160 |

| | |
|-----------------------------|-------|
| Re-measure | 4-160 |
| RESOLUTN LOW HIGH | 4-161 |
| RESTART | 4-161 |
| SATUR-ATION | 4-161 |
| SAVE | 4-162 |
| SAVE ANTENNA | 4-162 |
| SAVE CABLE | 4-162 |
| SAVE COLORS | 4-163 |
| Save Disk | 4-163 |
| SAVE EDIT | 4-163 |
| Save Internal | 4-164 |
| SAVE LIMITS | 4-164 |
| SAVE LIN GRAPH | 4-164 |
| SAVE LIST | 4-165 |
| SAVE LOG GRAPH | 4-165 |
| SAVE OTHER | 4-166 |
| Save/Rcl List | 4-166 |
| SAVE SETUP | 4-166 |
| SAV LOCK ON OFF | 4-167 |
| SCALE LOG LIN | 4-167 |
| SELECT | 4-168 |
| SELECT 1 2 3 4 | 4-168 |
| SELECT AMPLITUD | 4-168 |
| Select Axis | 4-169 |
| SELECT DELT AMP | 4-169 |
| SELECT FREQ | 4-170 |
| SELECT FRM LIST | 4-171 |
| SELECT LWR AMPL | 4-171 |
| SELECT MID AMPL | 4-171 |
| SELECT POINT | 4-172 |
| SELECT PREFIX | 4-172 |
| SELECT SEGMENT | 4-173 |
| Select Type | 4-174 |
| SELECT UPR AMPL | 4-175 |
| Selectv Mark | 4-175 |
| Service Cal | 4-176 |
| Service Diag | 4-176 |
| SET ATTN ERROR | 4-176 |
| SET DATE | 4-176 |
| SET TIME | 4-177 |
| SETTINGS ON OFF | 4-177 |

| | |
|-------------------|-------|
| SETUP | 4-177 |
| SETUP -> DISK | 4-178 |
| SHOW Δ1 PK QP AV | 4-178 |
| SHOW Δ2 PK QP AV | 4-178 |
| SHOW COR ON OFF | 4-179 |
| SHOW DET PK QP AV | 4-179 |
| SHOW MKR ON OFF | 4-179 |
| SHOW SETUP | 4-180 |
| SHW INST CONFIG | 4-180 |
| SIG LIST ON OFF | 4-180 |
| SIGNAL ANALYSIS | 4-181 |
| Signal Marking | 4-181 |
| SINGLE | 4-181 |
| SLOPE | 4-181 |
| SOFTKEYS | 4-182 |
| SORT BY AVG AMP | 4-182 |
| SORT BY FREQ | 4-182 |
| SORT BY ΔTA LIM | 4-183 |
| SORT BY PK AMP | 4-183 |
| SORT BY QP AMP | 4-183 |
| Sort Signals | 4-183 |
| SPAN or SPAN | 4-184 |
| SPAN ZOOM | 4-184 |
| SPEAKER ON OFF | 4-185 |
| Special Colors | 4-185 |
| SQUELCH | 4-185 |
| SRC ATN MAN AUTO | 4-186 |
| SRC PWR OFFSET | 4-186 |
| SRC PWR ON OFF | 4-186 |
| SRC PWR STP SIZE | 4-187 |
| START FREQ | 4-187 |
| STATE -> INTRNL | 4-187 |
| STATUS | 4-188 |
| STEP LOG LIN | 4-188 |
| STOP | 4-188 |
| STOP FREQ | 4-188 |
| STORE FLATNESS | 4-189 |
| STOR PWR ON UNITS | 4-189 |
| STP GAIN ZERO | 4-189 |
| STUVWX | 4-190 |
| SWEEP | 4-190 |

| | |
|-------------------|-------|
| SWEEP CONT SGL | 4-190 |
| SWEEP LOG LIN | 4-190 |
| SWEEP RAMP | 4-191 |
| SWEEP TIME DAC | 4-191 |
| SWP CPLG SR RECV | 4-191 |
| SWP TIME AUTO MAN | 4-192 |
| TEST | 4-192 |
| Test Patterns | 4-192 |
| THINKJET | 4-193 |
| THRESHLD ON OFF | 4-193 |
| Time Date | 4-193 |
| TIMEDATE ON OFF | 4-194 |
| TRACE | 4-194 |
| TRACE A B C | 4-194 |
| TRACE A | 4-195 |
| TRACE B | 4-195 |
| TRACE C | 4-196 |
| Trace -> Disk | 4-196 |
| Trace -> Intrnl | 4-197 |
| TRACK GEN | 4-197 |
| TRACKING PEAK | 4-197 |
| TRIG | 4-198 |
| TUNE SLO FAST | 4-198 |
| UNDO | 4-198 |
| VERT LINES | 4-199 |
| User Menus | 4-199 |
| VID AVG ON OFF | 4-199 |
| VIDEO | 4-200 |
| VIEW Δ OFF | 4-200 |
| VIEW A | 4-200 |
| VIEW B | 4-201 |
| VIEW C | 4-201 |
| VIEW CAL ON OFF | 4-201 |
| VIEW PK QP AV | 4-202 |
| VISION ENHANCE1 | 4-202 |
| VISION ENHANCE2 | 4-202 |
| Volts | 4-203 |
| Watts | 4-203 |
| WHITE DOTS | 4-203 |
| WHITE FILL | 4-203 |
| WINDOWS OFF | 4-204 |

| | |
|---------------------------|-------|
| X FINE TUNE DAC | 4-204 |
| YTF DRIVER | 4-204 |
| YTF SPAN | 4-205 |
| YTF TUNE COARSE | 4-205 |
| YTF TUNE FINE | 4-205 |
| YZ_# Spc Clear | 4-206 |
| ZERO SPAN | 4-206 |
| ZONE CENTER | 4-206 |
| ZONE PK LEFT | 4-207 |
| ZONE PK RIGHT | 4-207 |
| ZONE SPAN | 4-208 |
| ZOOM | 4-208 |

5. Error Messages

| | |
|--|------|
| Nonrecoverable System Errors | 5-14 |
|--|------|

A. SRQ

| | |
|---|-----|
| Service Requests | A-1 |
| Status Byte Definition | A-1 |
| Service Request Activating Commands | A-3 |

Index

Figures

| | |
|---|------|
| 1-1. HP 8542E EMI Receiver Dimensions | 1-19 |
| 1-2. HP 85422E Receiver RF Section Dimensions | 1-36 |
| 2-1. HP 8546A EMI Receiver Dimensions | 2-19 |
| 2-2. HP 85462A Receiver RF Section Dimensions | 2-37 |
| 4-1. Internal Memory Catalog Information | 4-35 |
| 4-2. Connecting a Printer to the Instrument | 4-49 |

Tables

| | |
|---|-------|
| 4-1. Center Frequency and Span Settings for Harmonic Bands | 4-25 |
| 4-2. Internal Memory Catalog Information* | 4-36 |
| 4-3. Setting of Thinkjet Printer Mode Switches | 4-47 |
| 4-4. Functions Which Exit The Windows Display Format | 4-52 |
| 4-5. Default Configuration Values | 4-55 |
| 4-6. Preset Conditions for Receiver Mode of Operation | 4-143 |
| 4-7. Preset Conditions for Signal Analysis Mode of Operation | 4-144 |
| 4-8. Preset Receiver Conditions | 4-145 |
| 4-9. Preset Spectrum Conditions | 4-147 |
| 4-10. | 4-151 |
| A-1. Status Byte Definition | A-2 |

HP 8542E/HP 85422E Specifications and Characteristics

This chapter contains specifications and characteristics for the HP 8542E EMI receiver and HP 85422E receiver RF section.

The specifications in this chapter apply to all functions autocoupled over the environmental conditions specified. All specifications apply after two hours of storage at a constant temperature within the operating temperature range, after the instrument has been operating for 60 minutes, and after CAL ALL has been run.

Definitions of Terms

The distinction between specifications, characteristics, typical performance, and nominal values is described as follows:

- *Specifications* describe warranted performance.
- *Characteristics* provide useful, but nonwarranted information about the functions and performance of the instrument.
- *Typical Performance*, where listed, is *not* warranted, but indicates performance which most units will exhibit.
- *Nominal Value* is an expected, but *not* warranted, value of the parameter.

HP 8542E EMI Receiver

General Specifications: HP 8542E EMI Receiver

| | |
|------------------------------|------------------|
| Temperature Range | |
| Operating* | 0 °C to +55 °C |
| Storage | -20 °C to +65 °C |
| * Disk drive +5 °C to +45 °C | |

| |
|---|
| EMI Compatibility |
| Receiver is in compliance with CISPR Pub. 16. |
| Receiver radiated and conducted emissions performance is in compliance with CISPR Pub. 11/1990 Group 1 Class B. |
| Receiver susceptibility performance is in compliance with CISPR Pub. 16 at 3 V/m field strength. |

| | |
|----------------|--------------------------------|
| Inputs | |
| Low frequency | Type N, 50 Ω, 9 kHz to 50 MHz |
| High frequency | Type N, 50 Ω, 9 kHz to 2.9 GHz |

| | |
|------------------|---|
| Detectors | |
| Measurement | Peak, Quasi-Peak, and Average Quasi-Peak and Average time constants conform with CISPR Pub.16. |
| Overload | Broadband RF (band 1 and 2 only) and IF |

| | |
|----------------------|--|
| IF Bandwidths | |
| Measurement | 200 Hz, 9 kHz, and 120 kHz (6 dB bandwidths which conform to CISPR Pub.16) |
| Bandwidth Accuracy | 1 MHz, 6 dB bandwidth $\pm 10\%$ |
| Diagnostic | 30 Hz to 300 kHz, 3 dB bandwidths in 1,3,10 steps ($\pm 20\%$ characteristic), also 3 MHz and 5 MHz. Four-pole synchronously-tuned, approximately Gaussian shape. |

| | |
|-----------------------------|--|
| Averaging Bandwidths | |
| | 30 Hz to 1 MHz in 1,3,10 steps ($\pm 30\%$ characteristic), and 3 MHz. Post-detection single pole low-pass filters. 1,3,10 Hz digital filters with anti-aliasing |

HP 8542E EMI Receiver

General Specifications: HP 8542E EMI Receiver (continued)

| | |
|---------------------------|------------|
| Input Attenuator | |
| Range | 0 to 50 dB |
| Linearity Test Attenuator | 4 dB |

| | |
|-------------------------|---------------------------|
| Preamplification | |
| | 12 dB (Band 1 and 2) |
| | 27 dB \pm 4 dB (Bypass) |

| | |
|---------------------|-----------|
| Demodulation | AM and FM |
|---------------------|-----------|

| | |
|-------------------|---|
| Disk Drive | Internal 3.5 inch disk drive, compatible with 1.44 MByte DOS and LIF format disks |
|-------------------|---|

| Input Filter Bandwidths | Frequency Range | Filter Type |
|---|------------------------|---------------------|
| (all 3 dB bandwidths are characteristics) | 9 kHz to 74 kHz | fixed |
| | 74 kHz to 198 kHz | fixed |
| | 198 kHz to 525 kHz | fixed |
| | 525 kHz to 1025 kHz | fixed |
| | 1 MHz to 2 MHz | fixed |
| | 2 MHz to 6 MHz | tunable (20%, 3 dB) |
| | 6 MHz to 17 MHz | tunable (10%, 3 dB) |
| | 17 MHz to 29 MHz | tunable (7%, 3 dB) |
| | 29 MHz to 52 MHz | tunable (8%, 3 dB) |
| | 52 MHz to 98 MHz | tunable (6%, 3 dB) |
| | 98 MHz to 152 MHz | tunable (6%, 3 dB) |
| | 152 MHz to 216 MHz | tunable (6%, 3 dB) |
| | 216 MHz to 330 MHz | tunable (5%, 3 dB) |
| | 330 MHz to 500 MHz | tunable (5%, 3 dB) |
| 0.5 GHz to 1 GHz | tunable (4%, 3 dB) | |
| 1 GHz to 2.9 GHz | fixed | |

HP 8542E EMI Receiver

General Specifications: HP 8542E EMI Receiver (continued)

| | | |
|-------------------|--|---|
| Sweep Time | | |
| Range | | 20 ms to 100 s |
| Sweep Trigger | | Free Run, Single, Line, Video, External |

| | |
|----------------------|------------------------------|
| Audible Noise | <5.5 Bels power (ISODP 7779) |
|----------------------|------------------------------|

| | | |
|---------------------------|---------------------|---|
| Power Requirements | | |
| On | Receiver RF Section | 90 to 132 V rms, 47 to 440 Hz 198 to 264 V rms, 47 to 66 Hz Power consumption <500 VA; <180 W |
| | RF Filter Section | 90 to 132 V rms, 47 to 440 Hz 198 to 264 V rms, 47 to 66 Hz Power consumption <115 VA; <85 W |
| Off | Receiver RF Section | Power consumption <5 W |

| | |
|--|---|
| Environmental Conditions | |
| Environment | Indoor Use |
| Altitude | Up to 15,000 feet (4,572 meters) |
| Maximum Relative Humidity | 80% for temperatures up to 31 °C decreasing linearly to 50% relative humidity at 40 °C. |
| INSTALLATION CATEGORY II according to IEC 1010 | |
| POLLUTION DEGREE 2 according to IEC 664 | |

Tuning Specifications

| | |
|---------------------|-------------------|
| Tuning Range | |
| Band 1 | 9 kHz to 50 MHz |
| Band 2 | 20 MHz to 2.9 GHz |
| Bypass | 9 kHz to 2.9 GHz |

| | |
|----------------------------|------------------------------|
| Frequency Reference | |
| Aging | $\pm 1 \times 10^{-7}$ /year |
| Settability | $\pm 1 \times 10^{-8}$ |
| Temperature Stability | $\pm 1 \times 10^{-8}$ |

| | |
|--|---|
| Frequency Readout Accuracy | \pm (frequency readout x frequency reference error * + span accuracy + 1% of span + 20% of IF Bandwidth + 100 Hz) † |
| *Frequency reference error=(aging rate x period of time since last adjustment + initial achievable accuracy + temperature stability). See frequency characteristics. | |
| †See "Drift" under "Stability" in frequency characteristics. | |

| | |
|--|--------------------------------|
| Calibrator | |
| Frequency | 300 MHz fundamental |
| Accuracy | see frequency reference error* |
| *Frequency reference error=(aging rate x period of time since last adjustment + initial achievable accuracy + temperature stability). See frequency characteristics. | |

Swept Frequency Specifications

| | | | | | | | |
|-----------------------|--|--------|-----------------|--------|------------------|--------|------------------|
| Frequency Span | | | | | | | |
| Range | <table> <tr> <td>Band 1</td> <td>1 kHz to 50 MHz</td> </tr> <tr> <td>Band 2</td> <td>1 kHz to 2.9 GHz</td> </tr> <tr> <td>Bypass</td> <td>1 kHz to 2.9 GHz</td> </tr> </table> | Band 1 | 1 kHz to 50 MHz | Band 2 | 1 kHz to 2.9 GHz | Bypass | 1 kHz to 2.9 GHz |
| Band 1 | 1 kHz to 50 MHz | | | | | | |
| Band 2 | 1 kHz to 2.9 GHz | | | | | | |
| Bypass | 1 kHz to 2.9 GHz | | | | | | |
| Resolution | Four digits or 20 Hz, whichever is greater | | | | | | |
| Accuracy* | | | | | | | |
| Span \leq 10 MHz | $\pm 2\%$ of Span + 10 Hz | | | | | | |
| Span $>$ 10 MHz | $\pm 3\%$ of Span | | | | | | |
| *Sweep time $>$ 75 ms | | | | | | | |

| | |
|---|-------------------------------|
| Stability | |
| Noise sidebands* | |
| $>$ 10 kHz offset from CW signal | ≤ -90 dBc/Hz |
| $>$ 30 kHz offset from CW signal | ≤ -105 dBc/Hz |
| Residual FM | |
| 30 Hz IF BW, 30 Hz Averaging BW | ≤ 30 Hz pk-pk in 300 ms |
| 1 kHz IF BW, 1 kHz Averaging BW | ≤ 250 Hz pk-pk in 100 ms |
| System Related Sidebands | ≤ -65 dBc |
| $>$ 30 kHz offset from CW signal | |
| * 1 kHz IF BW, 30 Hz averaging BW, sample detector. | |

| | |
|--|---|
| Marker Count Accuracy‡ | |
| Frequency Spans \leq 10 MHz | $\pm(\text{marker frequency} \times \text{frequency reference error}^* + \text{counter resolution} + 100 \text{ Hz})$ |
| Frequency Spans $>$ 10 MHz | $\pm(\text{marker frequency} \times \text{frequency reference error}^* + \text{counter resolution} + 1 \text{ kHz})$ |
| Counter Resolution | |
| Frequency Spans \leq 10 MHz | Selectable from 10 Hz to 100 kHz |
| Frequency Spans $>$ 10 MHz | Selectable from 100 Hz to 100 kHz |
| *Frequency reference error = (aging rate x period of time since last adjustment + initial achievable accuracy + temperature stability). See frequency characteristics. | |
| ‡Marker level to displayed noise level $>$ 25 dB, IF Bandwidth/Span \geq 0.01, Span \leq 300 MHz. | |

Amplitude Specifications

Amplitude specifications do not apply for negative peak detector mode except as noted in "Amplitude Characteristics."

| | |
|------------------------|--|
| Amplitude Range | -146 dBm to +30 dBm -39 dB μ V to +137 dB μ V |
|------------------------|--|

| Displayed Average Noise Level $f_o > 400$ kHz (input terminated, 0 dB attenuation, 30 Hz IF BW, 30 Hz Averaging BW, sample detection) | Band 1 9 kHz to 50 MHz | Band 2 20 MHz to 2.9 GHz | Bypass 9 kHz to 2.9 GHz |
|---|---|---------------------------------------|--------------------------------------|
| Preamplifier On | <----- ≤ -39 dB μ V -----> (-146 dBm) | | |
| Preamplifier Off | <----- ≤ -31 dB μ V -----> (-138 dBm) | | |
| Characteristic Noise Figure | | | |
| Preamplifier On | <----- 10 dB -----> | | |
| Preamplifier Off | <----- 14 dB -----> | | |

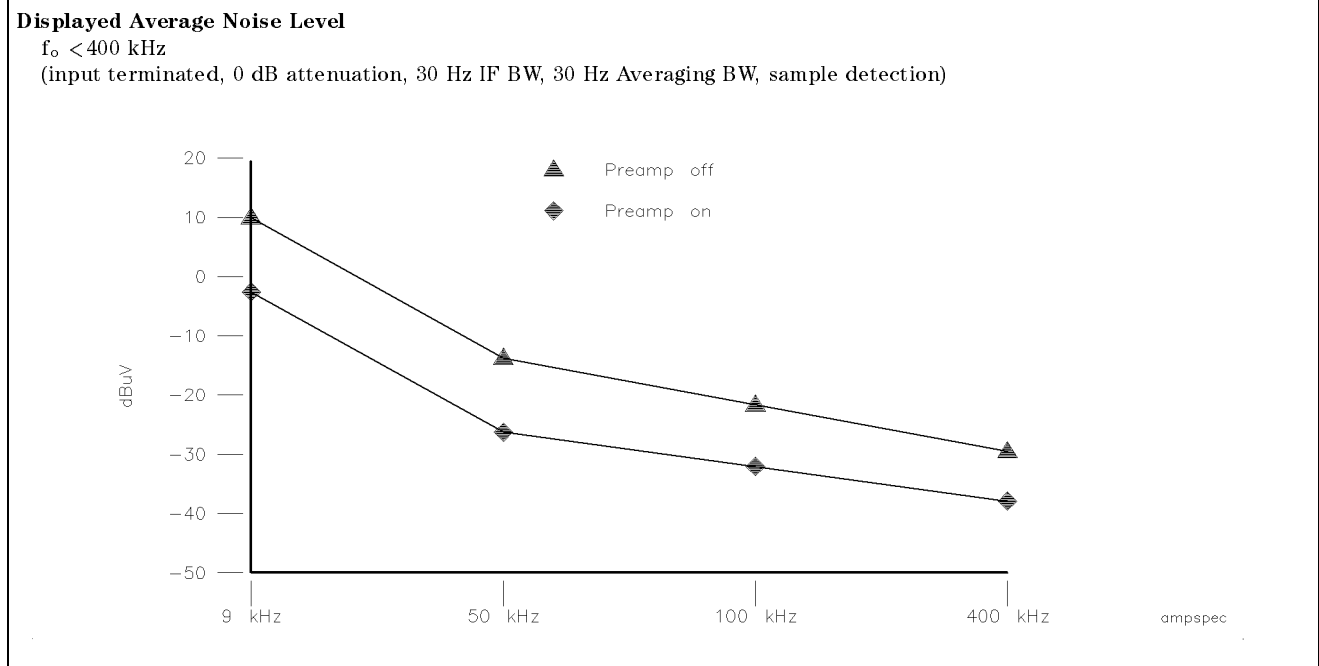

Amplitude Specifications (continued)

| Noise Indication in CISPR Bandwidths (Characteristic) 0 dB input attenuation, 50Ω input termination | Peak | Quasi-Peak | Average |
|---|--|---|---|
| | _____ | _____ | _____ |
| 200 Hz (6 dB), 9 kHz to 150 kHz Preamplifier On | 2 dB μ V to -28 dB μ V (-105 dBm to -135 dBm) | -7 dB μ V to -29 dB μ V (-114 dBm to -136 dBm) | -9 dB μ V to -31 dB μ V (-116 dBm to -138 dBm) |
| Preamplifier Off | 15 dB μ V to -15 dB μ V (-92 dBm to -122 dBm) | 6 dB μ V to -25 dB μ V (-101 dBm to -132 dBm) | 3 dB μ V to -27 dB μ V (-104 dBm to -134 dBm) |
| 9 kHz (6 dB), 150 kHz to 30 MHz Preamplifier On | -8 dB μ V (-115 dBm) | -15 dB μ V (-122 dBm) | -21 dB μ V (-128 dBm) |
| Preamplifier Off | -3 dB μ V (-110 dBm) | -11 dB μ V (-118 dBm) | -18 dB μ V (-125 dBm) |
| 120 kHz (6 dB), 30 MHz to 1 GHz Preamplifier On | 4 dB μ V (-103 dBm) | -2 dB μ V (-109 dBm) | -10 dB μ V (-117 dBm) |
| Preamplifier Off | 9 dB μ V (-98 dBm) | 2 dB μ V (-105 dBm) | -5 dB μ V (-112 dBm) |

| | Band 1 9 kHz to 50 MHz | Band 2 20 MHz to 2.9 GHz | Bypass 9 kHz to 2.9 GHz |
|--|------------------------------|--------------------------------|-------------------------------|
| | _____ | _____ | _____ |
| System Amplitude Accuracy | | | |
| Specification† | <----- ±2 dB -----> | | |
| Characteristic‡ | <----- ±1 dB -----> | | |
| † >(-10 dB μ V + attenuation + (12 - preamplifier gain)) reference level. Use Measure at Marker or linear mode, top 4 graticules. If using the Measure at Marker function to measure a pulsed signal with a repetition frequency of less than 5 Hz, set the sweep time to greater than or equal to the inverse of the pulse repetition frequency. (For example, to measure a 1 Hz CISPR pulse, set the sweep time to 1 second or greater prior to using the Measure at Marker function.) If IFBW \leq 300 Hz and signal separation \leq 4 kHz, also use Linearity Check. | | | |
| ‡ 20 °C to 30 °C plus the above. | | | |

Amplitude Specifications (continued)

| | Band 1 9 kHz to 50 MHz | Band 2 20 MHz to 2.9 GHz | Bypass 9 kHz to 2.9 GHz |
|---|--|---------------------------------------|--------------------------------------|
| Gain Compression* | | | |
| Specification | | | |
| $f_o \geq 10$ MHz | <----- <0.5 dB-----> | | |
| 200 kHz $\leq f_o < 10$ MHz | <----- <0.75 dB -----> | | |
| Characteristic 1 dB Compression Point | | | |
| $f_o \geq 10$ MHz | | | |
| Preamplifier On | <----- 77 dB μ V -----> (-30 dBm) | | |
| Preamplifier Off | <----- 89 dB μ V-----> (-18 dBm) | | |
| 9 kHz $< f_o < 10$ MHz | | | |
| Preamplifier On | 72 dB μ V (-35 dBm) | | |
| Preamplifier Off | 85 dB μ V (-22 dBm) | | |
| Third Harmonic Intercept Point** | | | |
| Specification | | | |
| $f_o > 200$ kHz | | | |
| Preamplifier On | <----- 85 dB μ V-----> (-22 dBm) | <- 85 dB μ V--> (-22 dBm) | |
| Preamplifier Off | <----- 97 dB μ V-----> (-10 dBm) | <- 112 dB μ V--> (+5 dBm) | |
| Characteristic | | | |
| $f_o \geq 10$ MHz | | | |
| Preamplifier On | <----- 92 dB μ V-----> (-15 dBm) | | |
| Preamplifier Off | <----- 101 dB μ V-----> (-6 dBm) | | |
| 9 kHz $< f_o < 10$ MHz | | | |
| Preamplifier On | <----- 89 dB μ V-----> (-18 dBm) | | |
| Preamplifier Off | <----- 100 dB μ V-----> (-7 dBm) | | |
| *Indicated specification is derived from measured distortion with a total power at the input mixer of -10 dBm. Bands 1 and 2: Power at the input mixer = input power - input attenuation + 15 dB + preamplifier gain. Bypass: Power at the input mixer = input power - input attenuation + preamplifier gain. If the IFBW is ≤ 300 Hz, this applies only if signal separation is ≥ 4 kHz and signal amplitudes \leq Ref. Level + 10 dB. | | | |
| ** Signal separation > 50 kHz. Indicated specification derived from measured distortion products for two -30 dBm CW signals at the input. | | | |

Amplitude Specifications (continued)

| | Band 1 9 kHz to 50 MHz | Band 2 20 MHz to 2.9 GHz | Bypass 9 kHz to 2.9 GHz |
|---|--|--------------------------------|-------------------------------|
| Second Harmonic Intercept Point* | | | |
| Specification† | | | |
| 100 kHz ≤ f ≤ 1.8 GHz | | | |
| Preamplifier On | <-----110 dB μ V-----> (+ 3 dBm) | | |
| Preamplifier Off | <-----122 dB μ V-----> (+ 15 dBm) | | |
| 1.8 GHz < f ≤ 2.9 GHz | | | |
| Preamplifier On | | 105 dB μ V (-2 dBm) | |
| Preamplifier Off | | 105 dB μ V (-2 dBm) | |
| Characteristic | | | |
| 9 kHz ≤ f ≤ 1.8 GHz | | | |
| Preamplifier On | <-----127 dB μ V-----> (+ 20 dBm) | | |
| Preamplifier Off | <-----137 dB μ V-----> (+ 30 dBm) | | |
| 1.8 GHz < f ≤ 2.9 GHz | | | |
| Preamplifier On | | 114 dB μ V (+ 7 dBm) | |
| Preamplifier Off | | 112 dB μ V (+ 5 dBm) | |
| * f is the receiver tune frequency (second harmonic frequency). | | | |
| † Indicated specification level was derived from measured harmonic levels for a -40 dBm input signal. | | | |

Amplitude Specifications (continued)

| | Band 1 9 kHz to 50 MHz | Band 2 20 MHz to 2.9 GHz | Bypass 9 kHz to 2.9 GHz |
|--|---|---|--|
| Other Input Related Spurious† | <----- -65 dBc-----> | | |
| Residual Responses Input terminated, 0 dB attenuation (preamplifier on) | | | |
| >30 kHz | <----- < -10 dB μ V -----> (-117 dBm) | | |
| <30 kHz | <----- < -2 dB μ V -----> (-109 dBm) | | |
| Maximum Safe Input Level Average Continuous Power | <----- +30 dBm-----> | | <--- +30 dBm---> (Input atten \geq 10 dB) |
| Peak Pulse Power | 2000 W peak for 10 μ s >20 dB input attenuation | 100 W for < 10 μ s pulse width <1% duty cycle and > 30 dB input attenuation | |
| DC (Volts) | <----- 0 V -----> | | |
| Input VSWR 0 dB input attenuation | | | |
| \leq 1.0 GHz | <----- 2 : 1 -----> | | |
| 1.0 GHz < f_o \leq 2.9 GHz | <--- 2.5 : 1 ---> | | |
| 10 dB input attenuation | | | |
| \leq 1.0 GHz | <----- 1.2 : 1 -----> | | |
| 1.0 GHz < f_o \leq 2.9 GHz | <--- 1.6 : 1 ---> | | |
| † 30 kHz offset for -20 dBm tone at the mixer \leq 2.9 GHz, f_o >10 MHz. Input mixer power = input power - input attenuation + 16.5 + preamplifier gain. | | | |

| | |
|----------------------------------|--|
| Marker Readout Resolution | 0.05 dB for log scale 0.05% of reference level for linear scale |
|----------------------------------|--|

Amplitude Specifications (continued)

| | |
|------------------------|----------------------------|
| Reference Level | |
| Range | |
| Log Scale | -146 dBm to +30 dBm |
| Linear Scale | -126 dBm to +30 dBm |
| Resolution | |
| Log Scale | ±0.01 dB |
| Linear Scale | ±0.12 % of reference level |

| | |
|--------------------------------|-----------------------------|
| Linear to Log Switching | ±0.25 dB at reference level |
|--------------------------------|-----------------------------|

| | |
|----------------------------------|--|
| Display Scale Fidelity | |
| Log Maximum Cumulative* | |
| 3 kHz to 3 MHz IF Bandwidth | ±(0.3 dB + 0.01 x dB from Reference level) |
| ≤ 1 kHz IF Bandwidth | ±(0.4 dB + 0.01 x dB from Reference level) |
| Log Incremental Accuracy | |
| 0 to -56 dB from Reference Level | ±0.4 dB/4 dB |
| Linear Accuracy | ±3% of Reference Level |

* 0 to -66 dB from reference level.

| Relative Quasi-Peak Response to a CISPR Pulse (dB)* | Frequency Bands | | |
|--|--------------------------------------|-------------------------------------|------------------------------------|
| | 120 kHz 6 dB BW 0.03 GHz to 1 GHz | 9 kHz 6 dB BW 0.15 MHz to 30 MHz | 200 Hz 6 dB BW 9 kHz to 150 kHz |
| Pulse Repetition Frequency (Hz) | | | |
| 1000 | +8.0 ±1.0 | +4.5 ±1.0 | -- |
| 100 | 0 dB (reference)† | 0 dB (reference)† | +4.0 ±1.0 |
| 60 | -- | -- | +3.0 ±1.0 |
| 25 | -- | -- | 0 dB (reference)† |
| 20 | -9.0 ±1.0 | -6.5 ±1.0 | -- |
| 10 | -14.0 ±1.5 | -10.0 ±1.5 | -4.0 ±1.0 |
| 5 | -- | -- | -7.5 ±1.5 |
| 2 | -26.0 ±2.0 | -20.5 ±2.0 | -13.0 ±2.0 |
| 1 | -28.5 ±2.0 | -22.5 ±2.0 | -17.0 ±2.0 |
| Isolated Pulse | -31.5 ±2.0 | -23.5 ±2.0 | -19.0 ±2.0 |

* Specification applies to a pulsed RF signal with equivalent spectral intensity as called out in CISPR Pub.16, Part 1. (CISPR pulse measurements require either an HP 8542E or HP 8546A EMI receiver and do not apply to either an HP 85422E or HP 85462A receiver RF section.)

† Reference pulse amplitude accuracy relative to the CW signal is <1.5 dB as specified in CISPR pub. 16. CISPR reference pulse: 0.044 μVs for .03 GHz to 1 GHz, 0.316 μVs for .15 MHz to 30 MHz, 13.5 ±1.5 μVs for 9 kHz to 150 kHz.

Tracking Generator Specifications

All Specifications apply over 0° C to 55° C. The receiver/tracking generator combination will meet its specification after 2 hours of storage at a constant temperature within the operating temperature range, 30 minutes after the combination is turned on, and after CAL ALL, CAL TRK GEN, and TRACKING PEAK have been run.

| | |
|-------------------------------|------------------|
| Output Frequency Range | 9 kHz to 2.9 GHz |
|-------------------------------|------------------|

| | |
|---------------------|------------|
| Warm-up time | 30 minutes |
|---------------------|------------|

| | |
|---|--------------------------|
| Output Power Level | |
| Range | -1 dBm to -66 dBm |
| Resolution | 0.1 dB |
| Vernier | |
| Range | 9 dB |
| Accuracy | |
| (25 °C ±10 °C) | |
| (-20 dBm at 300 MHz, 16 dB attenuation) | ±0.2 dB/dB |
| Incremental Cumulative | ±0.5 dB Total |
| Output Attenuator Range | 0 to 56 dB in 8 dB steps |

| | |
|---------------------------|---|
| Output Power Sweep | |
| Range | (-10 dBm to -1 dBm) - (source attenuator setting) |
| Resolution | 0.1 dB |

| | |
|---------------------------------------|------------|
| Tracking Generator Feedthrough | |
| 400 kHz to 2.9 GHz | ≤ -110 dBm |

| | |
|--|-----------|
| Spurious Output (-1 dBm output) | |
| Harmonic Spurs from 300 kHz to 2.9 GHz | |
| TG output 300 kHz to 2.9 GHz | ≤ -25 dBc |
| Non-harmonic Spurs from 300 kHz to 2.9 GHz | |
| TG output 300 kHz to 2.0 GHz | ≤ -27 dBc |
| TG output 2.0 GHz to 2.9 GHz | ≤ -23 dBc |
| LO Feedthrough | |
| LO frequency 3.9214 GHz to 6.8214 GHz | ≤ -16 dBm |

Frequency Characteristics

These are not specifications. Characteristics provide useful but nonwarranted information about instrument performance.

| | |
|-----------------------------|---|
| Frequency Reference | |
| Aging | 5×10^{-10} /day, 7 day average after being powered on for seven days |
| Warm-up | 1×10^{-8} after 30 minutes on |
| Initial Achievable Accuracy | $\pm 2.2 \times 10^{-8}$ after being powered on for 24 hours |

| | |
|--|--------------------------------|
| Stability | |
| Drift (after warm-up at stabilized temperature) Frequency spans ≤ 10 MHz, free run trigger | < 2 kHz/minute of sweep time |

Drift occurs only while receiver is sweeping frequency. Additional drift occurs when using Line, Video, or External trigger while waiting for the appropriate trigger.

Amplitude Characteristics

These are not specifications. Characteristics provide useful but nonwarranted information about instrument performance.

| Input Attenuator Uncertainty | |
|--|-------------|
| Attenuator Setting (Bypass) | |
| 0 dB | ± 0.2 dB |
| 10 dB | Reference |
| 20 dB | ± 0.4 dB |
| 30 dB | ± 0.5 dB |
| 40 dB | ± 0.7 dB |
| 50 dB | ± 0.8 dB |
| 10 dB Step Uncertainty (attenuator setting 10 to 50 dB) | ± 0.8 dB/dB |
| Repeatability | ±0.05 dB |

| FM Demodulation | |
|------------------------|-----------------------------------|
| Input Level | |
| Preamplifier Off | >(-75 dBm + attenuator setting) |
| Signal Level | 0 to -30 dB below reference level |
| FM Offset | 400 Hz nominal |
| FM Deviation (FM GAIN) | |
| Resolution | 1 kHz/volt nominal |
| Range | 10 kHz/volt to 1 MHz/volt |
| Bandwidth | FM Deviation ÷ 2 |
| FM Linearity | ≤ 1% of FM deviation + 290 Hz |

Tracking Generator Characteristics

| | |
|--|--|
| <p>Output Flatness (referenced to 300 MHz, -20 dBm)</p> <p>Frequency > 10 MHz Frequency ≤ 10 MHz</p> <p>Output Power Level Absolute Accuracy (-20 dBm at 300 MHz) (25 °C ± 10 °C)</p> | <p>±2 dB ±3 dB</p> <p>±0.75 dB</p> |
| <p>Tracking Drift Usable in a 1 kHz IF Bandwidth after a 5 minute warm-up</p> | <p>1.5 kHz/5 minutes</p> |
| <p>RF Power Off Residuals 9 kHz to 2.9 GHz</p> | <p>< -120 dBm</p> |
| <p>Dynamic Range (Difference between maximum power out and tracking generator feedthrough)</p> | <p>> 109 dB</p> |
| <p>Output Attenuator Repeatability</p> <p>300 kHz to 300 MHz 300 MHz to 2.0 GHz 2.0 GHz to 2.9 GHz</p> | <p>±0.1 dB ±0.2 dB ±0.3 dB</p> |
| <p>Output VSWR</p> <p>0 dB attenuation 8 dB attenuation</p> | <p><3.0:1 <1.5:1</p> |

Physical Characteristics

| Front Panel Inputs and Outputs | |
|--|---|
| Low Frequency Input | Type N female, 50 Ω nominal |
| High Frequency Input | Type N female, 50 Ω nominal |
| Tracking Generator Output | Type N female, 50 Ω nominal |
| Probe Power* Voltage / Current | + 15 Vdc \pm 7% at 150 mA maximum - 12.6 Vdc \pm 10% at 150 mA maximum |
| Earphone Jack | 1/8 inch monaural jack |
| * Total current drawn from the + 15 Vdc on the PROBE POWER and the AUX INTERFACE connectors cannot exceed 150 mA. Total current drawn from the -12.6 Vdc on the PROBE POWER and the -15 Vdc on the AUX INTERFACE cannot exceed 150 mA. | |

| Rear Panel Inputs and Outputs | |
|-------------------------------|---|
| 10 MHz REF OUTPUT | |
| Connector | BNC female |
| Impedance | 50 Ω |
| Output Amplitude | > 0 dBm |
| EXT REF IN | |
| Connector | BNC female |
| Input Amplitude Range | -2 dBm to +10 dBm |
| Frequency | 10 MHz |
| AUX IF OUT | |
| Connector | BNC female |
| Frequency | 21.4 MHz |
| Amplitude Range | -10 dBm to -60 dBm |
| Impedance | 50 Ω |
| AUX VIDEO OUT | |
| Connector | BNC female |
| Amplitude Range | 0 V to 1 V (uncorrected) |
| EXT KEYBOARD | Interface compatible with HP part number C1405 Option ABA and most IBM/AT non auto-switching keyboards. |
| EXT TRIG INPUT | |
| Connector | BNC female |
| Trigger Level | Positive edge initiates sweep in EXT TRIG mode (TTL) |
| LO OUTPUT | |
| Connector | SMA female (must be terminated in 50 Ω when not used) |
| Impedance | 50 Ω |
| Frequency Range | 3.0 GHz to 6.8214 GHz |

Physical Characteristics (continued)

| Rear Panel Inputs and Outputs (continued) | |
|---|-----------------------------------|
| HI-SWEEP IN/OUT | |
| Receiver RF Section Input/Output | |
| Connector | SMA female |
| Output | High = sweep, Low = retrace (TTL) |
| Input | Open collector, Low stops sweep |
| RF Filter Section Output | High = sweep, Low = retrace (TTL) |
| SWEEP INPUT / OUTPUT | |
| Receiver RF Section Output | |
| Connector | SMA female |
| Output | 0 V to +10 V ramp |
| RF Filter Section Input | |
| Connector | SMA female |
| Input | 0 V to +10 V |
| REMOTE INTERFACE | |
| Receiver RF Section | HP-IB (RS-232 optional) |
| RF Filter Section | HP-IB compatible service port |
| MONITOR OUTPUT | |
| | R, G, B (composite video on G) |
| | 25 kHz horizontal rate |
| | 60 Hz vertical rate |

| AUX INTERFACE | | | | | |
|--------------------------------------|------------------|---------|------------------|------------------|--|
| Connector Type: 9-pin subminiature D | | | | | |
| Connector Pinout: | | | | | |
| Pin # | Function | Current | Logic Mode | Serial Bit Mode | |
| 1 | Control A | — | TTL Output Hi/Lo | TTL Output Hi/Lo | |
| 2 | Control B | — | TTL Output Hi/Lo | TTL Output Hi/Lo | |
| 3 | Control C | — | TTL Output Hi/Lo | Strobe | |
| 4 | Control D | — | TTL Output Hi/Lo | Serial Data | |
| 5 | Control I | — | TTL Input Hi/Lo | TTL Input Hi/Lo | |
| 6 | Gnd | — | Gnd | Gnd | |
| 7* | -15 Vdc \pm 7% | 150 ma | — | — | |
| 8* | +5 Vdc \pm 5% | 150 ma | — | — | |
| 9* | +15 Vdc \pm 5% | 150 ma | — | — | |

* Total current drawn from the +15 Vdc on the PROBE POWER and the AUX INTERFACE cannot exceed 150 mA. Total current drawn from the -12.6 Vdc on the PROBE POWER and the -15 Vdc on the AUX INTERFACE cannot exceed 150 mA.

| WEIGHT | |
|---------------------|----------|
| Receiver RF Section | 62.5 lb. |
| RF Filter Section | 46 lb. |

HP 8542E EMI Receiver

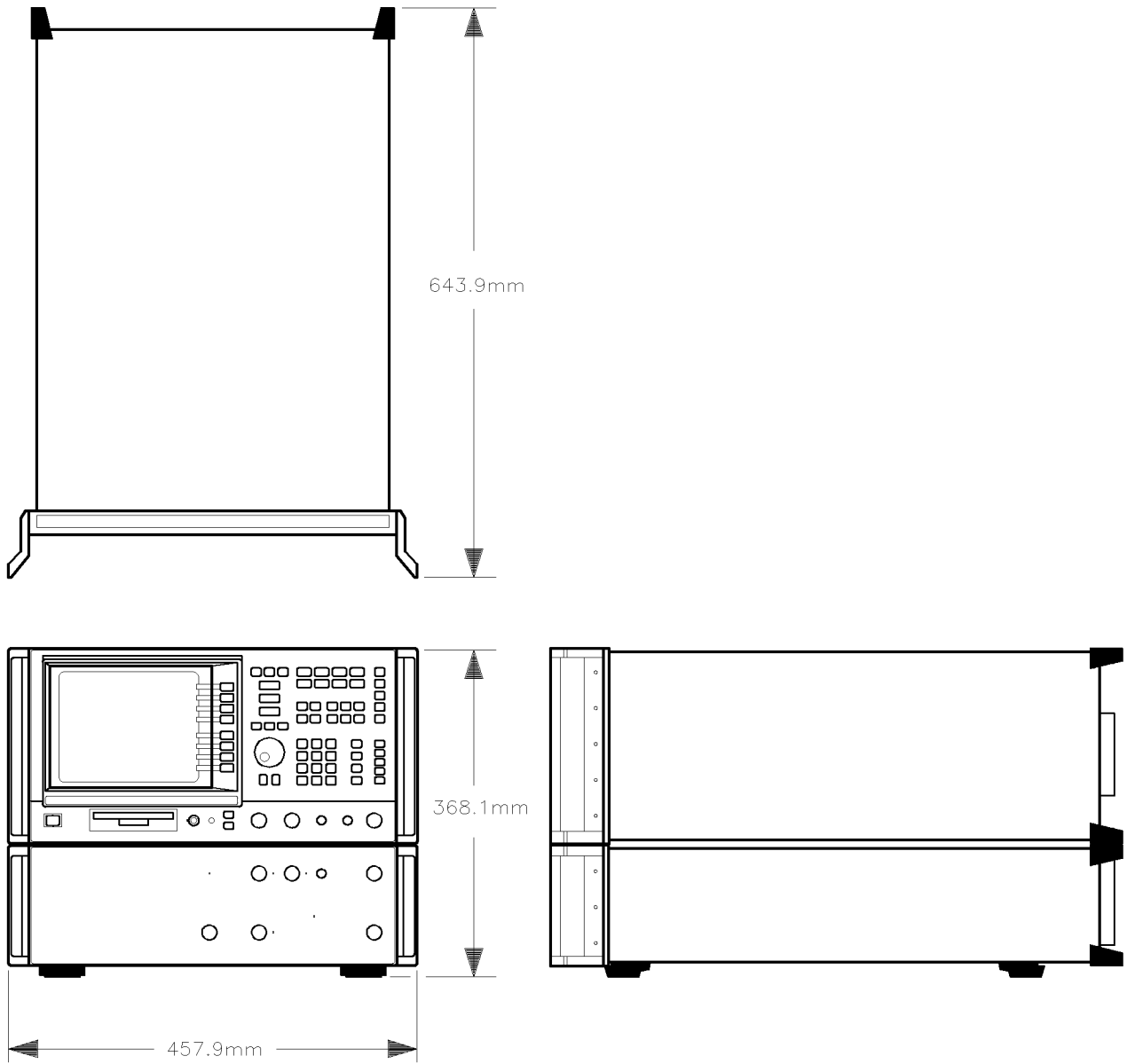

sysdim

Figure 1-1. HP 8542E EMI Receiver Dimensions

HP 85422E Receiver RF Section

General Specifications: HP 85422E Receiver RF Section

The specifications in this section apply to all functions autocoupled over the environmental conditions specified. All specifications apply after two hours of storage at a constant temperature within the operating temperature range, after the instrument has been operating for 60 minutes, and after CAL ALL has been run.

| | |
|------------------------------|------------------|
| Temperature Range | |
| Operating* | 0 °C to +55 °C |
| Storage | -20 °C to +65 °C |
| * Disk drive +5 °C to +45 °C | |

| |
|---|
| EMI Compatibility |
| Receiver RF section radiated and conducted emissions performance is in compliance with CISPR Pub. 11/1990 Group 1 Class B. Receiver RF section susceptibility is in compliance with CISPR Pub. 16 at 3 V/m. |

| | |
|---------------|--------------------------------|
| Inputs | Type N, 50 Ω, 9 kHz to 2.9 GHz |
|---------------|--------------------------------|

| | |
|------------------|--|
| Detectors | |
| Measurement | Peak, Quasi-Peak, and Average. Quasi-Peak and Average time constants conform with CISPR Pub.16. |
| Overload | IF |

| | |
|----------------------|--|
| IF Bandwidths | |
| Measurement | 200 Hz, 9 kHz, and 120 kHz (6 dB bandwidths which conform to CISPR Pub.16) |
| Bandwidth Accuracy | 1 MHz, 6 dB bandwidth $\pm 10\%$ |
| Diagnostic | 30 Hz to 300 kHz, 3 dB bandwidths in 1,3,10 steps ($\pm 20\%$ characteristic), also 3 MHz and 5 MHz. Four-pole synchronously-tuned, approximately Gaussian shape. |

| | |
|-----------------------------|--|
| Averaging Bandwidths | 30 Hz to 1 MHz in 1,3,10 steps ($\pm 30\%$ characteristic), and 3 MHz. Post-detection single pole low-pass filters. 1,3,10 Hz digital filters with anti-aliasing |
|-----------------------------|--|

| | |
|-------------------------|---------------------------|
| Input Attenuator | |
| Range | 0 to 70 dB in 10 dB steps |

| | |
|-------------------------|---|
| Preamplification | 27 dB ± 1.5 dB ≤ 500 MHz, ± 4 dB > 500 MHz |
|-------------------------|---|

| | |
|---------------------|-----------|
| Demodulation | AM and FM |
|---------------------|-----------|

General Specifications: HP 85422E Receiver RF Section (continued)

| | |
|---|---|
| <p>Sweep Time Range Accuracy Sweep Trigger</p> | <p>20 ms to 100 s $\pm 3\%$ Free Run, Single, Line, Video, External</p> |
| <p>Disk Drive</p> | <p>Internal 3.5 inch disk drive, compatible with 1.44 MByte DOS and LIF format disks</p> |
| <p>Audible Noise</p> | <p><5.5 Bels power (ISODP 7779)</p> |
| <p>Power Requirements On Off</p> | <p>90 to 132 V rms, 47 to 440 Hz 198 to 264 V rms, 47 to 66 Hz Power consumption <500 VA; <180 W Power consumption <5 W</p> |
| <p>Environmental Conditions Environment Altitude Maximum Relative Humidity INSTALLATION CATEGORY II according to IEC 1010 POLLUTION DEGREE 2 according to IEC 664</p> | <p>Indoor Use Up to 15,000 feet (4,572 meters) 80% for temperatures up to 31 °C decreasing linearly to 50% relative humidity at 40 °C.</p> |

Tuning Specifications

| | |
|---------------------|--------------------|
| Tuning Range | |
| DC Coupled | 9 kHz to 2.9 GHz |
| AC Coupled | 100 kHz to 2.9 GHz |

| | |
|----------------------------|------------------------------|
| Frequency Reference | |
| Aging | $\pm 1 \times 10^{-7}$ /year |
| Settability | $\pm 1 \times 10^{-8}$ |
| Temperature Stability | $\pm 1 \times 10^{-8}$ |

| | |
|-----------------------------------|---|
| Frequency Readout Accuracy | \pm (frequency readout x frequency reference error * + span accuracy + 1% of span + 20% of IF Bandwidth + 100 Hz) † |
|-----------------------------------|---|

*Frequency reference error=(aging rate x period of time since last adjustment + initial achievable accuracy + temperature stability). See frequency characteristics.

†See "Drift" under "Stability" in frequency characteristics.

| | |
|-------------------|--------------------------------|
| Calibrator | |
| Frequency | 300 MHz fundamental |
| Accuracy | see frequency reference error* |

*Frequency reference error=(aging rate x period of time since last adjustment + initial achievable accuracy + temperature stability). See frequency characteristics.

Swept Frequency Specifications

| | |
|-----------------------|--|
| Frequency Span | |
| Range | 1 kHz to 2.9 GHz |
| Resolution | Four digits or 20 Hz, whichever is greater |
| Accuracy | |
| Span \leq 10 MHz | $\pm 2\%$ of span + 10 Hz |
| Span $>$ 10 MHz | $\pm 3\%$ of span |

| | |
|---|-------------------------------|
| Stability | |
| Noise sidebands* | |
| > 10 kHz offset from CW signal | ≤ -90 dBc/Hz |
| > 30 kHz offset from CW signal | ≤ -105 dBc/Hz |
| Residual FM | |
| 30 Hz IF BW, 30 Hz Averaging BW | ≤ 30 Hz pk-pk in 300 ms |
| 1 kHz IF BW, 1 kHz Averaging BW | ≤ 250 Hz pk-pk in 100 ms |
| System Related Sidebands | |
| > 30 kHz offset from CW signal | ≤ -65 dBc |
| * 1 kHz IF BW, 30 Hz averaging BW, sample detector. | |

| | |
|-------------------------------|---|
| Marker Count Accuracy‡ | |
| Frequency Spans \leq 10 MHz | $\pm(\text{marker frequency} \times \text{frequency reference error}^* + \text{counter resolution} + 100 \text{ Hz})$ |
| Frequency Spans $>$ 10 MHz | $\pm(\text{marker frequency} \times \text{frequency reference error}^* + \text{counter resolution} + 1 \text{ kHz})$ |
| Counter Resolution | |
| Frequency Spans \leq 10 MHz | Selectable from 10 Hz to 100 kHz |
| Frequency Spans $>$ 10 MHz | Selectable from 100 Hz to 100 kHz |

*Frequency reference error = (aging rate x period of time since last adjustment + initial achievable accuracy + temperature stability). See frequency characteristics.

‡Marker level to displayed noise level > 25 dB, IF Bandwidth/Span ≥ 0.01 , Span ≤ 300 MHz.

Amplitude Specifications

Amplitude specifications do not apply for negative peak detector mode except as noted in “Amplitude Characteristics.”

| | |
|------------------------|--|
| Amplitude Range | -146 dBm to +30 dBm -39 dB μ V to +137 dB μ V |
|------------------------|--|

| | |
|--|-----------------------------------|
| Displayed Average Noise Level $f_o > 400$ kHz (input terminated, 0 dB attenuation, 30 Hz IF BW, 30 Hz Averaging BW, sample detection) | |
| Preamplifier On | -146 dBm (≤ -39 dB μ V) |
| Preamplifier Off | -125 dBm (≤ -18 dB μ V) |
| Characteristic Noise Figure | |
| Preamplifier On | 8 dB |
| Preamplifier Off | 24 dB |

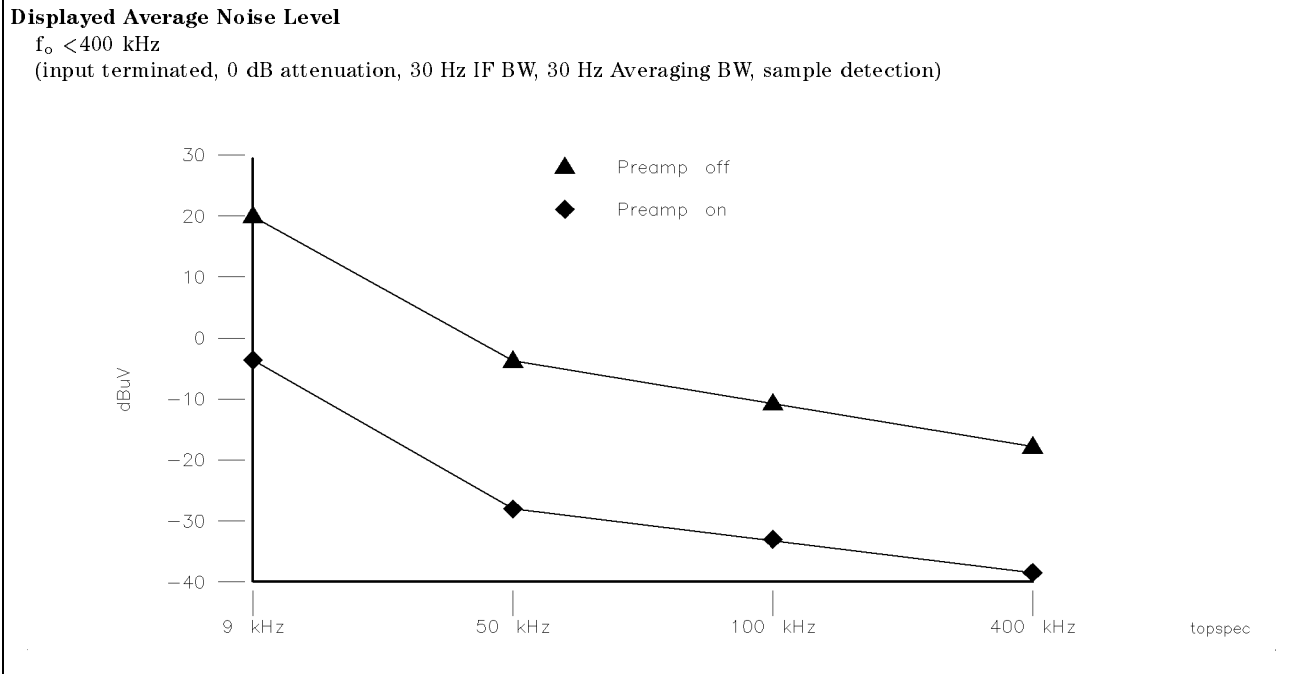

Amplitude Specifications (continued)

| | |
|--|-------------------------|
| Gain Compression* | |
| Specification | |
| $f_o > 10 \text{ MHz}$ | <0.5 dB |
| $200 \text{ kHz} \leq f_o \leq 10 \text{ MHz}$ | <0.75 dB |
| Characteristic 1 dB Compression Point | |
| $f_o > 10 \text{ MHz}$ | |
| Preamplifier On | 75 dB μ V (-32 dBm) |
| Preamplifier Off | 102 dB μ V (-5 dBm) |
| $9 \text{ kHz} \leq f_o \leq 10 \text{ MHz}$ | |
| Preamplifier On | 68 dB μ V (-39 dBm) |
| Preamplifier Off | 95 dB μ V (-12 dBm) |

* Specifications derived from distortion measurements using a two-tone compression test with frequency offset of 30 MHz and -10 dBm total signal power at the input mixer. Total power at first mixer = input power - input atten + preamp gain. IF BW \leq 300 Hz, this applies only if signal separation \geq 4 kHz and signal amplitudes \leq Reference Level + 10 dB.

| | |
|--|--------------------------|
| Third Order Intercept Point† | |
| Specification | |
| $f_o > 200 \text{ kHz}$ | |
| Preamplifier On | 85 dB μ V (-22 dBm) |
| Preamplifier Off | 112 dB μ V (+5 dBm) |
| Characteristic Third Order Intercept | |
| $f_o > 10 \text{ MHz}$ | |
| Preamplifier On | 89 dB μ V (-18 dBm) |
| Preamplifier Off | 118 dB μ V (+11 dBm) |
| $9 \text{ kHz} \leq f_o \leq 10 \text{ MHz}$ | |
| Preamplifier On | 87 dB μ V (-20 dBm) |
| Preamplifier Off | 115 dB μ V (+8 dBm) |

† Indicated specification was derived from a -70 dBc distortion product level with two -30 dBm CW signals at the first mixer and 50 kHz separation. Input mixer power = input power - input attenuation + preamp gain.

| | |
|---|--------------------------|
| Second Harmonic Intercept* | |
| $f_o > 200 \text{ kHz}$ | |
| Preamplifier On | 100 dB μ V (-9 dBm) |
| Preamplifier Off | 134 dB μ V (+27 dBm) |
| Characteristic Second Order Intercept | |
| Preamplifier On | |
| $f_o > 500 \text{ MHz}$ | 115 dB μ V (+8 dBm) |
| $9 \text{ kHz} \leq f_o \leq 500 \text{ MHz}$ | 108 dB μ V (+1 dBm) |
| Preamplifier Off | 144 dB μ V (+37 dBm) |

* The indicated specification level was derived from a measured harmonic level of <-67 dBc and a -40 dBm CW signal at the input mixer. Input mixer power = input power - input attenuation + preamp gain.

Amplitude Specifications (continued)

| | |
|-------------------------------------|---------|
| Other Input Related Spurious | -65 dBc |
|-------------------------------------|---------|

30 kHz offset for -20 dBm tone at the mixer ≤ 2.9 GHz, $f_o > 10$ MHz.
 Input mixer power = input power - input attenuation + preamp gain.

| | |
|---|--------------------------|
| Residual Responses | |
| Input terminated, 0 dB attenuation, preamplifier on | |
| 150 kHz to 2.9 GHz | -8 dB μ V (-115 dBm) |
| 9 kHz to 150 kHz | +2 dB μ V (-105 dBm) |

| | |
|---------------------------------|---|
| Maximum Safe Input Level | |
| Average Continuous Power | |
| 9 kHz to 2.9 GHz | +30 dBm (with 10 dB input attenuation) |
| Peak Pulse Power | |
| Preamplifier Off | +50 dBm (100 W) for 10 μ s pulse width and, 1% duty cycle, input atten ≥ 30 dB. |
| DC | 0 V (dc coupled) 50 V (ac coupled) |

| | |
|--------------------------|----------------------|
| Calibrator Output | |
| Amplitude | -20 dBm \pm 0.4 dB |

| | |
|--|---------------|
| Calibration Repeatability* | ± 0.15 dB |
| *Repeatability in the measured absolute amplitude of the CAL OUT signal at the reference settings after CAL FREQ and CAL AMPTD self-calibration. Absolute amplitude reference settings are: -20 dB reference level; 10 dB input attenuation; 300 MHz center frequency; 3 kHz IF BW; 300 Hz averaging BW; linear scale; 50 kHz span; coupled sweep time; reference level positioned at the top graticule; corrections on; and sample detection. | |

| | |
|----------------------|--|
| Display Range | |
| Log Scale | 0 to -66 dB from Reference Level is calibrated 0.1, 0.2, 0.5 dB/division and 1 to 20 dB/division in 1dB steps; eight divisions displayed |
| Linear Scale | Eight divisions |
| Scale Units | dBm, dBmV, dB μ V, V, W |

| | |
|----------------------------------|--|
| Marker Readout Resolution | 0.05 dB for log scale 0.05% of reference level for linear scale |
|----------------------------------|--|

Amplitude Specifications (continued)

| | |
|------------------------|------------------------------------|
| Reference Level | |
| Range | |
| Log Scale | -146 dBm to +30 dBm |
| Linear Scale | -126 dBm to +30 dBm |
| Resolution | |
| Log Scale | ±0.01 dB |
| Linear Scale | ±0.12% of Reference Level |
| Accuracy* | |
| 0 dBm to -59.9 dBm | ±(0.3 dB + 0.01 x dB from -20 dBm) |
| -60 dBm and below | |
| 1 kHz to 3 MHz IF BW | ±(0.6 dB + 0.01 x dB from -20 dBm) |
| 30 Hz to 300 Hz IF BW | ±(0.7 dB + 0.01 x dB from -20 dBm) |

* Referenced to -20 dBm reference level, 10 dB input attenuation, at a single frequency, in a fixed IF BW with preamplifier off. With preamplifier on, subtract preamplifier gain from all reference levels.

| | |
|--------------------------------|-----------------------------|
| Linear to Log Switching | ±0.25 dB at reference level |
|--------------------------------|-----------------------------|

| | |
|--|--|
| Display Scale Fidelity | |
| Log Maximum Cumulative (0 to -66 dB from Reference Level) | |
| 3 kHz to 3 MHz IF Bandwidth | ±(0.3 dB + 0.01 x dB from Reference Level) |
| ≤ 1 kHz IF Bandwidth | ±(0.4 dB + 0.01 x dB from Reference Level) |
| Log Incremental Accuracy (0 to -56 dB from Reference Level) | ±0.4 dB/4 dB |
| Linear Accuracy | ±3% of Reference Level |

| | |
|--|---------|
| IF Bandwidth Switching Uncertainty (at Reference Level, referenced to 3 kHz IF BW) | |
| 3 kHz to 3 MHz | ±0.4 dB |
| 1 kHz | ±0.5 dB |
| 30 Hz to 300 Hz | ±0.6 dB |

| | | |
|--|------------------|---------|
| Flatness (dc coupled, 10 dB input attenuation) | | |
| | 9 kHz to 2.9 GHz | |
| | Preamplifier On | ±3.0 dB |
| Preamplifier Off | ±1.5 dB | ±1.0 dB |

* Referenced to 300 MHz Calibrator.

† Referenced to midpoint between highest and lowest frequency response deviations.

Tracking Generator Specifications

All Specifications apply over 0° C to 55° C. The receiver/tracking generator combination will meet its specification after 2 hours of storage at a constant temperature within the operating temperature range, 30 minutes after the combination is turned on, and after CAL ALL, CAL TRK GEN, and TRACKING PEAK have been run.

| | |
|-------------------------------|------------------|
| Output Frequency Range | 9 kHz to 2.9 GHz |
|-------------------------------|------------------|

| | |
|---------------------|------------|
| Warm-up time | 30 minutes |
|---------------------|------------|

| | |
|---|--------------------------|
| Output Power Level | |
| Range | -1 dBm to -66 dBm |
| Resolution | 0.1 dB |
| Absolute Accuracy (-20 dBm at 300 MHz) (25 °C ±10 °C) | ±0.75 dB |
| Vernier | |
| Range | 9 dB |
| Accuracy (25 °C ±10 °C) (-20 dBm at 300 MHz, 16 dB attenuation) | ±0.2 dB/dB |
| Incremental Cumulative | ±0.5 dB Total |
| Output Attenuator Range | 0 to 56 dB in 8 dB steps |

| | |
|---------------------------|---|
| Output Power Sweep | |
| Range | (-10 dBm to -1 dBm) - (source attenuator setting) |
| Resolution | 0.1 dB |

| | |
|--|-------|
| Output Flatness (referenced to 300 MHz, -20 dBm) | |
| Frequency > 10 MHz | ±2 dB |
| Frequency ≤ 10 MHz | ±3 dB |

| | |
|---|------------|
| Tracking Generator Feedthrough 400 kHz to 2.9 GHz | ≤ -110 dBm |
|---|------------|

Tracking Generator Specifications (continued)

| | |
|--|----------------|
| Spurious Output (-1 dBm output) | |
| Harmonic Spurs from 300 kHz to 2.9 GHz TG output 300 kHz to 2.9 GHz | ≤ -25 dBc |
| Non-harmonic Spurs from 300 kHz to 2.9 GHz TG output 300 kHz to 2.0 GHz | ≤ -27 dBc |
| TG output 2.0 GHz to 2.9 GHz | ≤ -23 dBc |
| LO Feedthrough LO frequency 3.9214 GHz to 6.8214 GHz | ≤ -16 dBm |

Frequency Characteristics

These are not specifications. Characteristics provide useful but nonwarranted information about instrument performance.

| | |
|-----------------------------|---|
| Frequency Reference | |
| Aging | 5×10^{-10} /day, 7 day average after being powered on for seven days |
| Warm-up | 1×10^{-8} after 30 minutes on |
| Initial Achievable Accuracy | $\pm 2.2 \times 10^{-8}$ after being powered on for 24 hours |

| | |
|--|--------------------------------|
| Stability | |
| Drift (after warm-up at stabilized temperature) Frequency spans ≤ 10 MHz, free run trigger | < 2 kHz/minute of sweep time |

Drift occurs only while receiver is sweeping frequency. Additional drift occurs when using Line, Video, or External trigger while waiting for the appropriate trigger.

Amplitude Characteristics

These are not specifications. Characteristics provide useful but nonwarranted information about instrument performance.

| Input Attenuator Uncertainty | |
|--|-----------|
| Attenuator Setting | |
| 0 dB | ± 0.2 dB |
| 10 dB | Reference |
| 20 dB | ± 0.4 dB |
| 30 dB | ± 0.5 dB |
| 40 dB | ± 0.7 dB |
| 50 dB | ± 0.8 dB |
| 60 dB | ± 1.0 dB |
| 70 dB | ± 1.0 dB |
| 10 dB Step Uncertainty (attenuator setting 10 to 70 dB) | ± 0.8 dB |
| Repeatability | ±0.05 dB |

| AC Coupled Insertion Loss * | |
|------------------------------------|--------------------------|
| 100 kHz to 300 kHz | 0.7 dB |
| 300 kHz to 1 MHz | 0.2 dB |
| 1 MHz to 100 MHz | 0.07 dB |
| 100 MHz to 2.9 GHz | 0.05 dB + (0.06 × F)† dB |
| * Referenced to dc coupled mode. | |
| † F = frequency in GHz. | |

| Marker Readout Resolution (digitizing resolution) | |
|---|----------------------------|
| Log Scale | ±0.31 dB |
| Linear Scale | |
| Frequency ≤ 1 GHz | ±0.59 % of Reference Level |
| Frequency ≥ 1 GHz | ±1.03 % of Reference Level |

Amplitude Characteristics (continued)

| FM Demodulation | |
|------------------------|--|
| Input Level | $>(-60 \text{ dBm} + \text{attenuator setting})$ |
| Signal Level | 0 to -30 dB below reference level |
| FM Offset | 400 Hz nominal |
| FM Deviation (FM GAIN) | |
| Resolution | 1 kHz/volt nominal |
| Range | 10 kHz/volt to 1 MHz/volt |
| Bandwidth (6 dB) | $\text{FM Deviation} \div 2$ |
| FM Linearity | $\leq 1\%$ of FM deviation + 290 Hz |

Tracking Generator Characteristics

| | |
|--|--|
| <p>Tracking Drift Usable in a 1 kHz IF Bandwidth after a 5 minute warm-up</p> | <p>1.5 kHz/5 minutes</p> |
| <p>RF Power Off Residuals 9 kHz to 2.9 GHz</p> | <p>< -120 dBm</p> |
| <p>Dynamic Range (Difference between maximum power out and tracking generator feedthrough)</p> | <p>> 109 dB</p> |
| <p>Output Attenuator Repeatability 300 kHz to 300 MHz 300 MHz to 2.0 GHz 2.0 GHz to 2.9 GHz</p> | <p>±0.1 dB ±0.2 dB ±0.3 dB</p> |
| <p>Output VSWR 0 dB attenuation 8 dB attenuation</p> | <p><3.0:1 <1.5:1</p> |

Physical Characteristics

| Front Panel Inputs and Outputs | |
|-----------------------------------|---|
| Input | Type N female, 50 Ω nominal |
| Calibrator Output | Type N female, 50 Ω nominal |
| Tracking Generator Output | Type N female, 50 Ω nominal |
| Probe Power* Voltage / Current | +15 Vdc \pm 7% at 150 mA max. -12.6 Vdc \pm 10% at 150 mA max. |
| Earphone Jack | 1/8 inch monaural jack |
| External ALC | Negative Detector |

* Total current drawn from the +15 Vdc on the PROBE POWER and the AUX INTERFACE connectors cannot exceed 150 mA. Total current draw from the -12.6 Vdc on the PROBE POWER and the -15 Vdc on the AUX INTERFACE connectors cannot exceed 150 mA.

| Rear Panel Inputs and Outputs | |
|-------------------------------|------------------------|
| 10 MHz REF OUTPUT | |
| Connector | BNC female |
| Impedance | 50 Ω |
| Output Amplitude | >0 dBm |
| EXT REF IN | |
| Connector | BNC female |
| Input Amplitude Range | -2 dBm to +10 dBm |
| Frequency | 10 MHz |
| AUX IF OUT | |
| Connector | BNC female |
| Frequency | 21.4 MHz |
| Amplitude Range | -10 dBm to -60 dBm |
| Impedance | 50 Ω |
| AUX VIDEO OUT | |
| Connector | BNC female |
| Amplitude Range | 0 to 1 V (uncorrected) |

Physical Characteristics (continued)

| Rear Panel Inputs and Outputs (continued) | |
|---|---|
| EXT KEYBOARD | Interface compatible with HP part number C1405 Option ABA and most IBM/AT non auto-switching keyboards. |
| EXT TRIG INPUT | |
| Connector | BNC female |
| Trigger Level | Positive edge initiates sweep in EXT TRIG mode (TTL) |
| LO OUTPUT | |
| Connector | SMA female (must be terminated in 50 Ω when not used) |
| Impedance | 50 Ω |
| Frequency Range | 3.0 to 6.8214 GHz |
| HI-SWEEP IN/OUT (input/output 85422E) | |
| Connector | SMA female |
| Output | High=sweep, Low = retrace (TTL) |
| Input | Open collector, low stops sweep |
| SWEEP INPUT / OUTPUT (output 85422E) | |
| Connector | SMA female |
| Output | 0 to +10 V ramp |
| REMOTE INTERFACE (85422E) | HP-IB (RS-232 optional) |
| MONITOR OUTPUT | R, G, B (composite video on G) 25 kHz horizontal rate 60 Hz vertical rate |

AUX INTERFACE

Connector Type: 9-pin subminiature D

Connector Pinout:

| Pin # | Function | Current | Logic Mode | Serial Bit Mode |
|-------|-------------|---------|------------------|------------------|
| 1 | Control A | --- | TTL Output Hi/Lo | TTL Output Hi/Lo |
| 2 | Control B | --- | TTL Output Hi/Lo | TTL Output Hi/Lo |
| 3 | Control C | --- | TTL Output Hi/Lo | Strobe |
| 4 | Control D | --- | TTL Output Hi/Lo | Serial Data |
| 5 | Control I | --- | TTL Input Hi/Lo | TTL Input Hi/Lo |
| 6 | Gnd | --- | Gnd | Gnd |
| 7* | -15 Vdc ±7% | 150 ma | --- | --- |
| 8* | +5 Vdc ±5% | 150 ma | --- | --- |
| 9* | +15 Vdc ±5% | 150 ma | --- | --- |

* Total current drawn from the +15 Vdc on the PROBE POWER and the AUX INTERFACE cannot exceed 150 mA. Total current drawn from the -12.6 Vdc on the PROBE POWER and the -15 Vdc on the AUX INTERFACE cannot exceed 150 mA.

WEIGHT

Receiver RF Section

62.5 lb.

HP 85422E Receiver RF Section

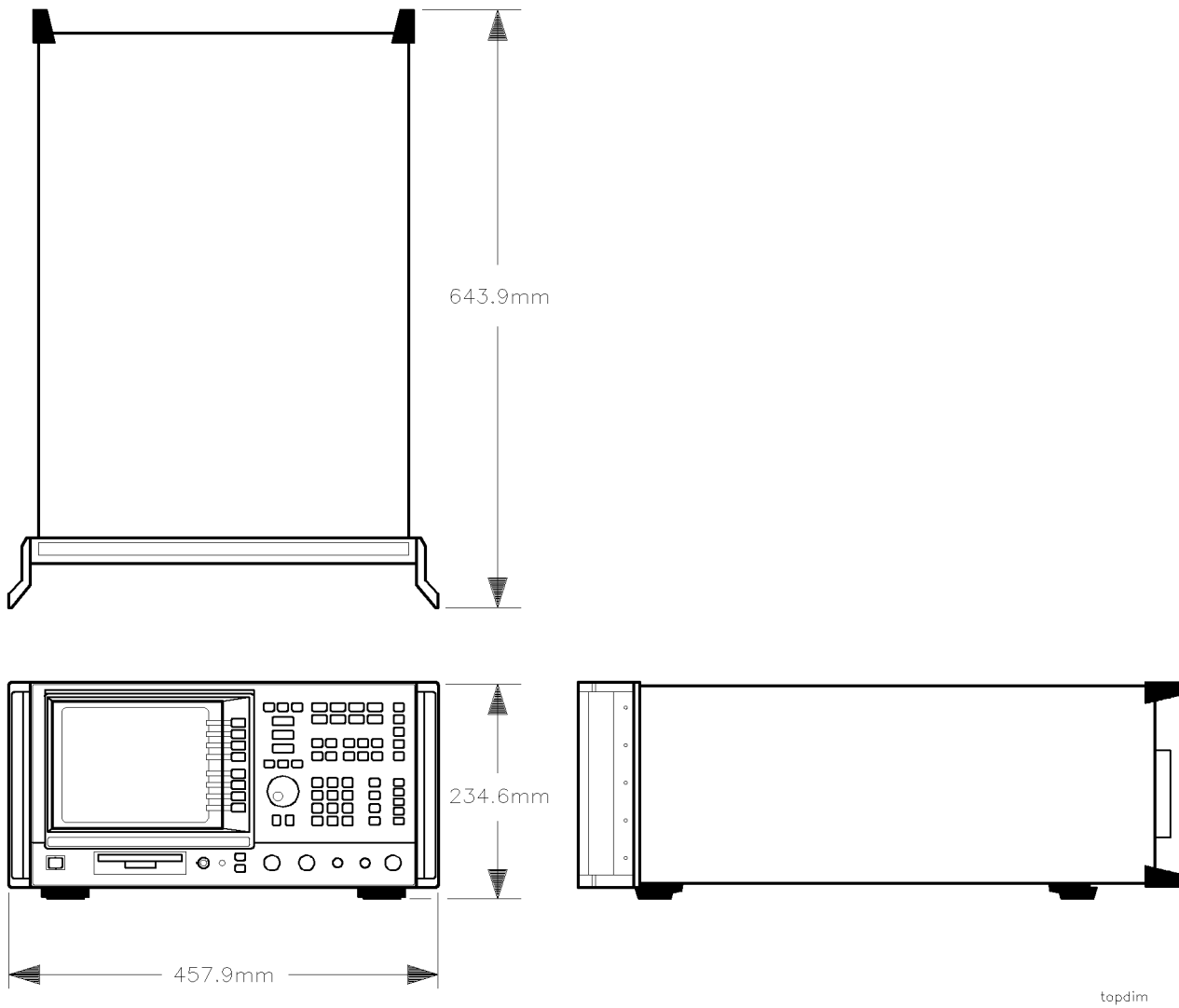

Figure 1-2. HP 85422E Receiver RF Section Dimensions

Regulatory Information

The information on the following page applies to the HP 8542E EMI receiver and HP 85422E receiver RF section.

DECLARATION OF CONFORMITY

according to ISO/IEC Guide 22 and EN 45014

Manufacturer's Name: Hewlett-Packard Co.

Manufacturer's Address: Santa Rosa Systems Division
1400 Fountaingrove Parkway
Santa Rosa, CA 95403-1799
USA

declares that the product

Product Name: EMI Receiver

Model Number: HP 8542E, HP 85420E, HP 85422E,
HP 8546A, HP 85460A, HP 85462A

Product Options: This declaration covers all options of the
above product.

conforms to the following Product specifications:

Safety: IEC 1010-1:1990+A1 / EN 61010-1:1993
CAN/CSA-C22.2 No. 1010.1-92

EMC: CISPR 11:1990/EN 55011:1991 Group 1, Class B
IEC 801-2:1984/EN 50082-1:1992 4 kV CD, 8 kV AD
IEC 801-3:1984/EN 50082-1:1992 3 V/m, 27-500 MHz
IEC 801-4:1988/EN 50082-1:1992 0.5 kV Sig. Lines, 1 kV Power Lines

Supplementary Information:

The product herewith complies with the requirements of the Low Voltage Directive 73/23/EEC and the EMC Directive 89/336/EEC.

Santa Rosa, California, USA 11 Sept 1995

Dixon Browder/Quality Manager

European Contact: Your local Hewlett-Packard Sales and Service Office or Hewlett-Packard GmbH, Department ZQ/Standards Europe, Herrenberger Strasse 130, D-71034 Böblingen, Germany (FAX +49-7031-14-3143)

Notice for Germany: Noise Declaration

LpA < 70 dB
am Arbeitsplatz (operator position)
normaler Betrieb (normal position)
nach DIN 45635 T. 19 (per ISO 7779)

HP 8546A/HP 85462A Specifications and Characteristics

This chapter contains specifications and characteristics for the HP 8546A EMI receiver and HP 85462A receiver RF section.

The specifications in this chapter apply to all functions autocoupled over the environmental conditions specified. All specifications apply after two hours of storage at a constant temperature within the operating temperature range, after the instrument has been operating for 60 minutes, and after CAL ALL and CAL YTF have been run.

Definitions of Terms

The distinction between specifications, characteristics, typical performance, and nominal values is described as follows:

- *Specifications* describe warranted performance.
- *Characteristics* provide useful, but nonwarranted information about the functions and performance of the instrument.
- *Typical Performance*, where listed, is *not* warranted, but indicates performance which most units will exhibit.
- *Nominal Value* is an expected, but *not* warranted, value of the parameter.

HP 8546A EMI Receiver

General Specifications: HP 8546A EMI Receiver

| | |
|------------------------------|------------------|
| Temperature Range | |
| Operating* | 0 °C to +55 °C |
| Storage | -20 °C to +65 °C |
| * Disk drive +5 °C to +45 °C | |

| |
|---|
| EMI Compatibility |
| Receiver is in compliance with CISPR Pub. 16. |
| Receiver radiated and conducted emissions performance is in compliance with CISPR Pub. 11/1990 Group 1 Class B. |
| Receiver susceptibility performance is in compliance with CISPR Pub. 16 at 3 V/m field strength. |

| | |
|----------------|--------------------------------|
| Inputs | |
| Low frequency | Type N, 50 Ω, 9 kHz to 50 MHz |
| High frequency | Type N, 50 Ω, 9 kHz to 6.5 GHz |

| | |
|------------------|---|
| Detectors | |
| Measurement | Peak, Quasi-Peak, and Average Quasi-Peak and Average time constants conform with CISPR Pub.16. |
| Overload | Broadband RF (band 1 and 2 only) and IF |

| | |
|----------------------|--|
| IF Bandwidths | |
| Measurement | 200 Hz, 9 kHz, and 120 kHz (6 dB bandwidths which conform to CISPR Pub.16) |
| Bandwidth Accuracy | 1 MHz, 6 dB bandwidth $\pm 10\%$ |
| Diagnostic | 30 Hz to 300 kHz, 3 dB bandwidths in 1,3,10 steps ($\pm 20\%$ characteristic), also 3 MHz and 5 MHz. Four-pole synchronously-tuned, approximately Gaussian shape. |

| | |
|-----------------------------|--|
| Averaging Bandwidths | 30 Hz to 1 MHz in 1,3,10 steps ($\pm 30\%$ characteristic), and 3 MHz. Post-detection single pole low-pass filters. 1,3,10 Hz digital filters with anti-aliasing |
|-----------------------------|--|

General Specifications: HP 8546A EMI Receiver (continued)

| | |
|---------------------------|------------|
| Input Attenuator | |
| Range | 0 to 50 dB |
| Linearity Test Attenuator | 4 dB |

| | |
|-------------------------|---|
| Preamplification | 12 dB (Band 1 and 2) 27 dB \pm 4 dB (Bypass) |
|-------------------------|---|

| | |
|---------------------|-----------|
| Demodulation | AM and FM |
|---------------------|-----------|

| | |
|-------------------|---|
| Disk Drive | Internal 3.5 inch disk drive, compatible with 1.44 MByte DOS and LIF format disks |
|-------------------|---|

| Input Filter Bandwidths | Frequency Range | Filter Type |
|---|------------------------|---------------------|
| (all 3 dB bandwidths are characteristics) | 9 kHz to 74 kHz | fixed |
| | 74 kHz to 198 kHz | fixed |
| | 198 kHz to 525 kHz | fixed |
| | 525 kHz to 1025 kHz | fixed |
| | 1 MHz to 2 MHz | fixed |
| | 2 MHz to 6 MHz | tunable (20%, 3 dB) |
| | 6 MHz to 17 MHz | tunable (10%, 3 dB) |
| | 17 MHz to 29 MHz | tunable (7%, 3 dB) |
| | 29 MHz to 52 MHz | tunable (8%, 3 dB) |
| | 52 MHz to 98 MHz | tunable (6%, 3 dB) |
| | 98 MHz to 152 MHz | tunable (6%, 3 dB) |
| | 152 MHz to 216 MHz | tunable (6%, 3 dB) |
| | 216 MHz to 330 MHz | tunable (5%, 3 dB) |
| | 330 MHz to 500 MHz | tunable (5%, 3 dB) |
| 0.5 GHz to 1 GHz | tunable (4%, 3 dB) | |
| 1 GHz to 2.9 GHz | fixed | |
| 1 GHz to 6.5 GHz | fixed | |

HP 8546A EMI Receiver

General Specifications: HP 8546A EMI Receiver (continued)

| | | |
|-------------------|--|---|
| Sweep Time | | |
| Range | | 20 ms to 100 s |
| Sweep Trigger | | Free Run, Single, Line, Video, External |

| | |
|----------------------|------------------------------|
| Audible Noise | <5.5 Bels power (ISODP 7779) |
|----------------------|------------------------------|

| | | |
|---------------------------|---------------------|---|
| Power Requirements | | |
| On | Receiver RF Section | 90 to 132 V rms, 47 to 440 Hz 198 to 264 V rms, 47 to 66 Hz Power consumption <500 VA; <180 W |
| | RF Filter Section | 90 to 132 V rms, 47 to 440 Hz 198 to 264 V rms, 47 to 66 Hz Power consumption <115 VA; <85 W |
| Off | Receiver RF Section | Power consumption <5 W |

| | |
|--|---|
| Environmental Conditions | |
| Environment | Indoor Use |
| Altitude | Up to 15,000 feet (4,572 meters) |
| Maximum Relative Humidity | 80% for temperatures up to 31 °C decreasing linearly to 50% relative humidity at 40 °C. |
| INSTALLATION CATEGORY II according to IEC 1010 | |
| POLLUTION DEGREE 2 according to IEC 664 | |

Tuning Specifications

| | |
|---------------------|-------------------|
| Tuning Range | |
| Band 1 | 9 kHz to 50 MHz |
| Band 2 | 20 MHz to 2.9 GHz |
| Band 3 | 1 GHz to 6.5 GHz |
| Bypass | 9 kHz to 6.5 GHz |

| | |
|----------------------------|------------------------------|
| Frequency Reference | |
| Aging | $\pm 1 \times 10^{-7}$ /year |
| Settability | $\pm 1 \times 10^{-8}$ |
| Temperature Stability | $\pm 1 \times 10^{-8}$ |

| | |
|--|---|
| Frequency Readout Accuracy | \pm (frequency readout x frequency reference error * + span accuracy + 1% of span + 20% of IF Bandwidth + 100 Hz) † |
| *Frequency reference error=(aging rate x period of time since last adjustment + initial achievable accuracy + temperature stability). See frequency characteristics. | |
| †See "Drift" under "Stability" in frequency characteristics. | |

| | |
|--|--------------------------------|
| Calibrator | |
| Frequency | 300 MHz fundamental |
| Accuracy | see frequency reference error* |
| *Frequency reference error=(aging rate x period of time since last adjustment + initial achievable accuracy + temperature stability). See frequency characteristics. | |

Swept Frequency Specifications

| | | |
|-----------------------|--|--------------------------|
| Frequency Span | | |
| Range | Band 1 | 1 kHz to 50 MHz |
| | Band 2 | 1 kHz to 2.9 GHz |
| | Band 3 | 1 kHz to 5.5 GHz |
| | Bypass | 1 kHz to 6.5 GHz |
| Resolution | Four digits or 20 Hz, whichever is greater | |
| Accuracy* | Bands 1 and 2 | Band 3 and Bypass |
| Span \leq 10 MHz | $\pm 2\%$ of Span + 10 Hz | $\pm 4\%$ of Span |
| Span $>$ 10 MHz | $\pm 3\%$ of Span | $\pm 6\%$ of Span |
| *Sweep time $>$ 75 ms | | |

| | |
|---|-------------------------------|
| Stability | |
| Noise sidebands* | |
| > 10 kHz offset from CW signal | ≤ -90 dBc/Hz |
| > 30 kHz offset from CW signal | ≤ -105 dBc/Hz |
| Residual FM | |
| 30 Hz IF BW, 30 Hz Averaging BW | ≤ 30 Hz pk-pk in 300 ms |
| 1 kHz IF BW, 1 kHz Averaging BW | ≤ 250 Hz pk-pk in 100 ms |
| System Related Sidebands | ≤ -65 dBc |
| > 30 kHz offset from CW signal | |
| * 1 kHz IF BW, 30 Hz averaging BW, sample detector. | |

| | |
|--|---|
| Marker Count Accuracy ‡ | |
| Frequency Spans \leq 10 MHz | $\pm(\text{marker frequency} \times \text{frequency reference error}^* + \text{counter resolution} + 100 \text{ Hz})$ |
| Frequency Spans $>$ 10 MHz | $\pm(\text{marker frequency} \times \text{frequency reference error}^* + \text{counter resolution} + 1 \text{ kHz})$ |
| Counter Resolution | |
| Frequency Spans \leq 10 MHz | Selectable from 10 Hz to 100 kHz |
| Frequency Spans $>$ 10 MHz | Selectable from 100 Hz to 100 kHz |
| *Frequency reference error = (aging rate x period of time since last adjustment + initial achievable accuracy + temperature stability). See frequency characteristics. | |
| ‡Marker level to displayed noise level $>$ 25 dB, IF Bandwidth/Span \geq 0.01, Span \leq 300 MHz. | |

Amplitude Specifications

Amplitude specifications do not apply for negative peak detector mode except as noted in "Amplitude Characteristics."

| | |
|------------------------|--|
| Amplitude Range | -146 dBm to +30 dBm -39 dB μ V to +137 dB μ V |
|------------------------|--|

| Displayed Average Noise Level $f_o > 400$ kHz (input terminated, 0 dB attenuation, 30 Hz IF BW, 30 Hz Averaging BW, sample detection) | Band 1 9 kHz to 50 MHz | Band 2 20 MHz to 2.9 GHz | Band 3 1 GHz to 6.5 GHz | Bypass 9 kHz to 6.5 GHz |
|---|---|---------------------------------------|--------------------------------------|--------------------------------------|
| Preamplifier On | <--- ≤ -39 dB μ V ---> (-146 dBm) | | ≤ -37 dB μ V (-144 dBm) | |
| Preamplifier Off | <--- ≤ -31 dB μ V ---> (-138 dBm) | | ≤ -16 dB μ V (-123 dBm) | |
| Characteristic Noise Figure | | | | |
| Preamplifier On | <----- 10 dB -----> | | 8 dB | |
| Preamplifier Off | <----- 14 dB -----> | | 24 dB | |

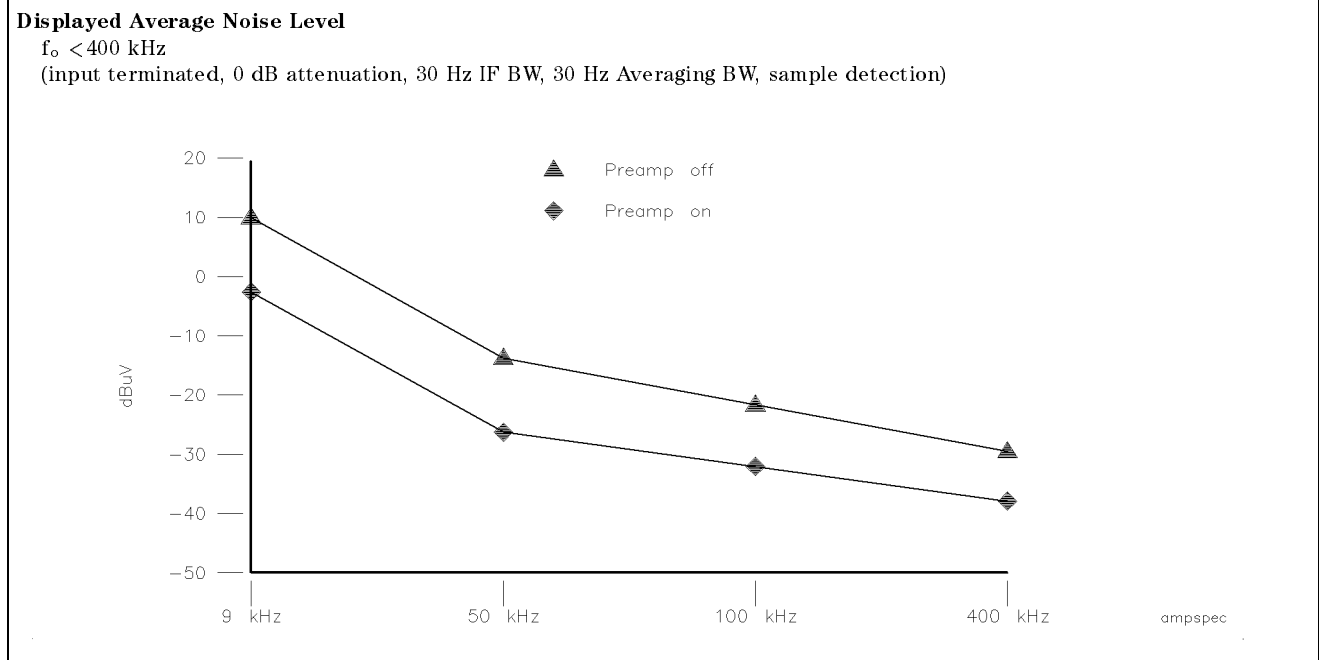

Amplitude Specifications (continued)

| Noise Indication in CISPR Bandwidths (Characteristic) 0 dB input attenuation, 50Ω input termination | Peak | Quasi-Peak | Average |
|--|--|---|---|
| | _____ | _____ | _____ |
| 200 Hz (6 dB), 9 kHz to 150 kHz Preamplifier On | 2 dB μ V to -28 dB μ V (-105 dBm to -135 dBm) | -7 dB μ V to -29 dB μ V (-114 dBm to -136 dBm) | -9 dB μ V to -31 dB μ V (-116 dBm to -138 dBm) |
| Preamplifier Off | 15 dB μ V to -15 dB μ V (-92 dBm to -122 dBm) | 6 dB μ V to -25 dB μ V (-101 dBm to -132 dBm) | 3 dB μ V to -27 dB μ V (-104 dBm to -134 dBm) |
| 9 kHz (6 dB), 150 kHz to 30 MHz Preamplifier On | -8 dB μ V (-115 dBm) | -15 dB μ V (-122 dBm) | -21 dB μ V (-128 dBm) |
| Preamplifier Off | -3 dB μ V (-110 dBm) | -11 dB μ V (-118 dBm) | -18 dB μ V (-125 dBm) |
| 120 kHz (6 dB), 30 MHz to 1 GHz Preamplifier On | 4 dB μ V (-103 dBm) | -2 dB μ V (-109 dBm) | -10 dB μ V (-117 dBm) |
| Preamplifier Off | 9 dB μ V (-98 dBm) | 2 dB μ V (-105 dBm) | -5 dB μ V (-112 dBm) |

| | Band 1 | Band 2 | Band 3 | Bypass |
|--|--------------------|----------------------|---------------------|---------------------|
| | 9 kHz to 50 MHz | 20 MHz to 2.9 GHz | 1 GHz to 6.5 GHz | 9 kHz to 6.5 GHz |
| | _____ | _____ | _____ | _____ |
| System Amplitude Accuracy | | | | |
| Specification† | <-----±2 dB-----> | | | |
| Characteristic‡ | <-----±1 dB-----> | | ±3 dB | |
| † >(-10 dB μ V + attenuation + (12 - preamplifier gain)) reference level. Use Measure at Marker or linear mode, top 4 graticules. If using the Measure at Marker function to measure a pulsed signal with a repetition frequency of less than 5 Hz, set the sweep time to be greater than or equal to the inverse of the pulse repetition frequency. (For example, to measure a 1 Hz CISPR pulse, set the sweep time to 1 second or greater prior to using the Measure at Marker function.) If IFBW \leq 300 Hz and signal separation \leq 4 kHz, also use Linearity Check. ‡ 20 °C to 30 °C plus the above. (Plus YIG filter peaked, Band 3 only.) | | | | |

Amplitude Specifications (continued)

| | Band 1 | Band 2 | Band 3 | Bypass |
|--|--|----------------------|--|---------------------|
| | 9 kHz to 50 MHz | 20 MHz to 2.9 GHz | 1 GHz to 6.5 GHz | 9 kHz to 6.5 GHz |
| Gain Compression* | | | | |
| Specification | | | | |
| $f_o \geq 10$ MHz | <----- <0.5 dB -----> | | | |
| $200 \text{ kHz} < f_o < 10$ MHz | <----- <0.75 dB -----> | | | |
| Characteristic 1 dB Compression Point | | | | |
| $f_o \geq 10$ MHz | | | | |
| Preamplifier On | <----- 77 dB μ V -----> (-30 dBm) | | | |
| Preamplifier Off | <----- 89 dB μ V -----> (-18 dBm) | | 102 dB μ V (-5 dBm) | |
| $9 \text{ kHz} < f_o < 10$ MHz | | | | |
| Preamplifier On | 72 dB μ V (-35 dBm) | | | |
| Preamplifier Off | 85 dB μ V (-22 dBm) | | | |
| Third Harmonic Intercept Point** | | | | |
| Specification | | | | |
| $f_o > 200$ kHz | | | | |
| Preamplifier On | <----- 85 dB μ V -----> (-22 dBm) | | <----- 85 dB μ V -----> (-22 dBm) | |
| Preamplifier Off | <----- 97 dB μ V -----> (-10 dBm) | | <----- 112 dB μ V -----> (+5 dBm) | |
| Characteristic | | | | |
| $f_o \geq 10$ MHz | | | | |
| Preamplifier On | <----- 92 dB μ V -----> (-15 dBm) | | | |
| Preamplifier Off | <----- 101 dB μ V -----> (-6 dBm) | | | |
| $9 \text{ kHz} < f_o < 10$ MHz | | | | |
| Preamplifier On | <----- 89 dB μ V -----> (-18 dBm) | | | |
| Preamplifier Off | <----- 100 dB μ V -----> (-7 dBm) | | | |
| <p>*Indicated specification is derived from measured distortion with a total power at the input mixer of -10 dBm. Bands 1 and 2: Power at the input mixer=input power - input attenuation + 15 dB + preamplifier gain. Band 3 and Bypass: Power at the input mixer=input power - input attenuation + preamplifier gain. If the IFBW is ≤ 300 Hz, this applies only if signal separation is ≥ 4 kHz and signal amplitudes \leq Ref. Level + 10 dB.</p> <p>** Signal separation > 50 kHz. Indicated specification derived from measured distortion products for two -30 dBm CW signals at the input.</p> | | | | |

Amplitude Specifications (continued)

| | Band 1 9 kHz to 50 MHz | Band 2 20 MHz to 2.9 GHz | Band 3 1 GHz to 6.5 GHz | Bypass 9 kHz to 6.5 GHz |
|---|-------------------------------------|---------------------------------------|--------------------------------------|--------------------------------------|
| Second Harmonic Intercept Point* | | | | |
| Specification† | | | | |
| 100 kHz ≤ f ≤ 1.8 GHz, > 2.9 GHz | | | | |
| Preamplifier On | <-----110 dB _μ V-----> | | 100 dB _μ V | |
| | (+ 3 dBm) | | (- 7 dBm) | |
| Preamplifier Off | <-----122 dB _μ V-----> | | 134 dB _μ V | |
| | (+ 15 dBm) | | (+ 27 dBm) | |
| 1.8 GHz < f ≤ 2.9 GHz | | | | |
| Preamplifier On | | 105 dB _μ V | | |
| | | (- 2 dBm) | | |
| Preamplifier Off | | 105 dB _μ V | | |
| | | (- 2 dBm) | | |
| Characteristic | | | | |
| 9 kHz ≤ f ≤ 1.8 GHz | | | | |
| Preamplifier On | <-----127 dB _μ V-----> | | | |
| | (+ 20 dBm) | | | |
| Preamplifier Off | <-----137 dB _μ V-----> | | | |
| | (+ 30 dBm) | | | |
| 1.8 GHz < f ≤ 2.9 GHz | | | | |
| Preamplifier On | | 114 dB _μ V | | |
| | | (+ 7 dBm) | | |
| Preamplifier Off | | 112 dB _μ V | | |
| | | (+ 5 dBm) | | |

* f is the receiver tune frequency (second harmonic frequency).

† Indicated specification level was derived from measured harmonic levels for a -40 dBm input signal.

Amplitude Specifications (continued)

| | Band 1 9 kHz to 50 MHz | Band 2 20 MHz to 2.9 GHz | Band 3 1 GHz to 6.5 GHz | Bypass 9 kHz to 6.5 GHz |
|--|---|---------------------------------------|---|--------------------------------------|
| Other Input Related Spurious† | <----- -65 dBc-----> | | | |
| Residual Responses | | | | |
| Input terminated, 0 dB attenuation (preamplifier on) | | | | |
| >30 kHz | <----- < -10 dB μ V-----> (-117 dBm) | | | |
| <30 kHz | <----- < -2 dB μ V-----> (-109 dBm) | | | |
| Maximum Safe Input Level | | | | |
| Average Continuous Power | <----- +30 dBm-----> | | <----- +30 dBm-----> (Input atten \geq 10 dB) | |
| Peak Pulse Power | 2000 W peak for 10 μ s > 20 dB input attenuation | | 100 W for < 10 μ s pulse width <1% duty cycle and >30 dB input attenuation | |
| DC (Volts) | <----- 0 V -----> | | | |
| Input VSWR | | | | |
| 0 dB input attenuation | | | 3 : 1* | |
| \leq 1.0 GHz | <----- 2 : 1 -----> | | | |
| 1.0 GHz < f_o \leq 2.9 GHz | <----- 2.5 : 1 -----> | | | |
| 10 dB input attenuation | | | 2 : 1* | |
| \leq 1.0 GHz | <----- 1.2 : 1 -----> | | | |
| 1.0 GHz < f_o \leq 2.9 GHz | <----- 1.6 : 1 -----> | | | |
| † 30 kHz offset for -20 dBm tone at the mixer \leq 6.5 GHz, f_o >10 MHz. Input mixer power = input power - input attenuation + 16.5 + preamplifier gain. | | | | |
| * Characteristic only. | | | | |

| | |
|----------------------------------|--|
| Marker Readout Resolution | 0.05 dB for log scale 0.05% of reference level for linear scale |
|----------------------------------|--|

Amplitude Specifications (continued)

| | |
|------------------------|----------------------------|
| Reference Level | |
| Range | |
| Log Scale | -146 dBm to +30 dBm |
| Linear Scale | -126 dBm to +30 dBm |
| Resolution | |
| Log Scale | ±0.01 dB |
| Linear Scale | ±0.12 % of reference level |

| | |
|--------------------------------|-----------------------------|
| Linear to Log Switching | ±0.25 dB at reference level |
|--------------------------------|-----------------------------|

| | |
|----------------------------------|--|
| Display Scale Fidelity | |
| Log Maximum Cumulative* | |
| 3 kHz to 3 MHz IF Bandwidth | ±(0.3 dB + 0.01 x dB from Reference level) |
| ≤ 1 kHz IF Bandwidth | ±(0.4 dB + 0.01 x dB from Reference level) |
| Log Incremental Accuracy | |
| 0 to -56 dB from Reference Level | ±0.4 dB/4 dB |
| (0 to -54 dB, Band 3 only) | |
| Linear Accuracy | ±3% of Reference Level |

* 0 to -66 dB from reference level. 0 to -64 dB Band 3 only.

| Relative Quasi-Peak Response to a CISPR Pulse (dB)* | Frequency Bands | | |
|--|--------------------------------------|-------------------------------------|------------------------------------|
| | 120 kHz 6 dB BW 0.03 GHz to 1 GHz | 9 kHz 6 dB BW 0.15 MHz to 30 MHz | 200 Hz 6 dB BW 9 kHz to 150 kHz |
| Pulse Repetition Frequency (Hz) | | | |
| 1000 | +8.0 ±1.0 | +4.5 ±1.0 | -- |
| 100 | 0 dB (reference)† | 0 dB (reference)† | +4.0 ±1.0 |
| 60 | -- | -- | +3.0 ±1.0 |
| 25 | -- | -- | 0 dB (reference)† |
| 20 | -9.0 ±1.0 | -6.5 ±1.0 | -- |
| 10 | -14.0 ±1.5 | -10.0 ±1.5 | -4.0 ±1.0 |
| 5 | -- | -- | -7.5 ±1.5 |
| 2 | -26.0 ±2.0 | -20.5 ±2.0 | -13.0 ±2.0 |
| 1 | -28.5 ±2.0 | -22.5 ±2.0 | -17.0 ±2.0 |
| Isolated Pulse | -31.5 ±2.0 | -23.5 ±2.0 | -19.0 ±2.0 |

* Specification applies to a pulsed RF signal with equivalent spectral intensity as called out in CISPR Pub.16, Part 1. (CISPR pulse measurements require either an HP 8542E or HP 8546A EMI receiver and do *not* apply to either an HP 85422E or HP 85462A receiver RF section.)

† Reference pulse amplitude accuracy relative to the CW signal is <1.5 dB as specified in CISPR pub. 16. CISPR reference pulse: 0.044 μVs for .03 GHz to 1 GHz, 0.316 μVs for .15 MHz to 30 MHz, 13.5 ±1.5 μVs for 9 kHz to 150 kHz.

Tracking Generator Specifications

All Specifications apply over 0° C to 55° C. The receiver/tracking generator combination will meet its specification after 2 hours of storage at a constant temperature within the operating temperature range, 30 minutes after the combination is turned on, and after CAL ALL, CAL TRK GEN, and TRACKING PEAK have been run.

| | |
|-------------------------------|------------------|
| Output Frequency Range | 9 kHz to 2.9 GHz |
|-------------------------------|------------------|

| | |
|---------------------|------------|
| Warm-up time | 30 minutes |
|---------------------|------------|

| | |
|---|--------------------------|
| Output Power Level | |
| Range | -1 dBm to -66 dBm |
| Resolution | 0.1 dB |
| Vernier | |
| Range | 9 dB |
| Accuracy | |
| (25 °C ±10 °C) | |
| (-20 dBm at 300 MHz, 16 dB attenuation) | ±0.2 dB/dB |
| Incremental Cumulative | ±0.5 dB Total |
| Output Attenuator Range | 0 to 56 dB in 8 dB steps |

| | |
|---------------------------|---|
| Output Power Sweep | |
| Range | (-10 dBm to -1 dBm) - (source attenuator setting) |
| Resolution | 0.1 dB |

| | |
|---------------------------------------|------------|
| Tracking Generator Feedthrough | |
| 400 kHz to 2.9 GHz | ≤ -110 dBm |

| | |
|--|-----------|
| Spurious Output (-1 dBm output) | |
| Harmonic Spurs from 300 kHz to 2.9 GHz | |
| TG output 300 kHz to 2.9 GHz | ≤ -25 dBc |
| Non-harmonic Spurs from 300 kHz to 2.9 GHz | |
| TG output 300 kHz to 2.0 GHz | ≤ -27 dBc |
| TG output 2.0 GHz to 2.9 GHz | ≤ -23 dBc |
| LO Feedthrough | |
| LO frequency 3.9214 GHz to 6.8214 GHz | ≤ -16 dBm |

Frequency Characteristics

These are not specifications. Characteristics provide useful but nonwarranted information about instrument performance.

| | |
|-----------------------------|---|
| Frequency Reference | |
| Aging | 5×10^{-10} /day, 7 day average after being powered on for seven days |
| Warm-up | 1×10^{-8} after 30 minutes on |
| Initial Achievable Accuracy | $\pm 2.2 \times 10^{-8}$ after being powered on for 24 hours |

| | |
|--|--------------------------------|
| Stability | |
| Drift (after warm-up at stabilized temperature) Frequency spans ≤ 10 MHz, free run trigger | < 2 kHz/minute of sweep time |

Drift occurs only while receiver is sweeping frequency. Additional drift occurs when using Line, Video, or External trigger while waiting for the appropriate trigger.

Amplitude Characteristics

These are not specifications. Characteristics provide useful but nonwarranted information about instrument performance.

| Input Attenuator Uncertainty | |
|--|-------------|
| Attenuator Setting (Band 3 and Bypass) | |
| 0 dB | ± 0.2 dB |
| 10 dB | Reference |
| 20 dB | ± 0.4 dB |
| 30 dB | ± 0.5 dB |
| 40 dB | ± 0.7 dB |
| 50 dB | ± 0.8 dB |
| 10 dB Step Uncertainty (attenuator setting 10 to 50 dB) | ± 0.8 dB/dB |
| Repeatability | ±0.05 dB |

| Unpeaked Frequency Response (dc coupled) (without preselector peaking, Span ≤50 MHz, 10 dB input attenuation, Band 3 and Bypass only) | Absolute* | Relative† |
|---|-----------------|-----------|
| | 2.75 to 6.5 GHz | |
| Preamplifier On | ±3 dB | ±1 dB |
| Preamplifier Off | ±2 dB | ±1 dB |

* Referenced to 300 MHz CAL OUT.
† Referenced to midpoint between highest and lowest frequency response deviations.

| FM Demodulation | |
|------------------------|-----------------------------------|
| Input Level | |
| Preamplifier Off | >(-75 dBm + attenuator setting) |
| Signal Level | 0 to -30 dB below reference level |
| FM Offset | 400 Hz nominal |
| FM Deviation (FM GAIN) | |
| Resolution | 1 kHz/volt nominal |
| Range | 10 kHz/volt to 1 MHz/volt |
| Bandwidth | FM Deviation ÷ 2 |
| FM Linearity | ≤ 1% of FM deviation + 290 Hz |

Tracking Generator Characteristics

| | |
|--|--|
| <p>Output Flatness (referenced to 300 MHz, -20 dBm)</p> <p>Frequency > 10 MHz Frequency ≤ 10 MHz</p> <p>Output Power Level Absolute Accuracy (-20 dBm at 300 MHz) (25 °C ± 10 °C)</p> | <p>±2 dB ±3 dB</p> <p>±0.75 dB</p> |
| <p>Tracking Drift Usable in a 1 kHz IF Bandwidth after a 5 minute warm-up</p> | <p>1.5 kHz/5 minutes</p> |
| <p>RF Power Off Residuals 9 kHz to 2.9 GHz</p> | <p>< -120 dBm</p> |
| <p>Dynamic Range (Difference between maximum power out and tracking generator feedthrough)</p> | <p>> 109 dB</p> |
| <p>Output Attenuator Repeatability</p> <p>300 kHz to 300 MHz 300 MHz to 2.0 GHz 2.0 GHz to 2.9 GHz</p> | <p>±0.1 dB ±0.2 dB ±0.3 dB</p> |
| <p>Output VSWR</p> <p>0 dB attenuation 8 dB attenuation</p> | <p><3.0:1 <1.5:1</p> |

Physical Characteristics

| Front Panel Inputs and Outputs | |
|--|---|
| Low Frequency Input | Type N female, 50 Ω nominal |
| High Frequency Input | Type N female, 50 Ω nominal |
| Tracking Generator Output | Type N female, 50 Ω nominal |
| Probe Power* Voltage / Current | + 15 Vdc \pm 7% at 150 mA maximum - 12.6 Vdc \pm 10% at 150 mA maximum |
| Earphone Jack | 1/8 inch monaural jack |
| * Total current drawn from the + 15 Vdc on the PROBE POWER and the AUX INTERFACE connectors cannot exceed 150 mA. Total current drawn from the -12.6 Vdc on the PROBE POWER and the -15 Vdc on the AUX INTERFACE cannot exceed 150 mA. | |

| Rear Panel Inputs and Outputs | |
|-------------------------------|---|
| 10 MHz REF OUTPUT | |
| Connector | BNC female |
| Impedance | 50 Ω |
| Output Amplitude | > 0 dBm |
| EXT REF IN | |
| Connector | BNC female |
| Input Amplitude Range | -2 dBm to +10 dBm |
| Frequency | 10 MHz |
| AUX IF OUT | |
| Connector | BNC female |
| Frequency | 21.4 MHz |
| Amplitude Range | -10 dBm to -60 dBm |
| Impedance | 50 Ω |
| AUX VIDEO OUT | |
| Connector | BNC female |
| Amplitude Range | 0 V to 1 V (uncorrected) |
| EXT KEYBOARD | Interface compatible with HP part number C1405 Option ABA and most IBM/AT non auto-switching keyboards. |
| EXT TRIG INPUT | |
| Connector | BNC female |
| Trigger Level | Positive edge initiates sweep in EXT TRIG mode (TTL) |
| LO OUTPUT | |
| Connector | SMA female (must be terminated in 50 Ω when not used) |
| Impedance | 50 Ω |
| Frequency Range | 3.0 GHz to 6.8214 GHz |

Physical Characteristics (continued)

| Rear Panel Inputs and Outputs (continued) | |
|---|-----------------------------------|
| HI-SWEEP IN/OUT | |
| Receiver RF Section Input/Output | |
| Connector | SMA female |
| Output | High = sweep, Low = retrace (TTL) |
| Input | Open collector, Low stops sweep |
| RF Filter Section Output | High = sweep, Low = retrace (TTL) |
| SWEEP INPUT / OUTPUT | |
| Receiver RF Section Output | |
| Connector | SMA female |
| Output | 0 V to +10 V ramp |
| RF Filter Section Input | |
| Connector | SMA female |
| Input | 0 V to +10 V |
| REMOTE INTERFACE | |
| Receiver RF Section | HP-IB (RS-232 optional) |
| RF Filter Section | HP-IB compatible service port |
| MONITOR OUTPUT | |
| | R, G, B (composite video on G) |
| | 25 kHz horizontal rate |
| | 60 Hz vertical rate |

| AUX INTERFACE | | | | | |
|--|-------------------|---------|------------------|------------------|--|
| Connector Type: 9-pin subminiature D | | | | | |
| Connector Pinout: | | | | | |
| Pin # | Function | Current | Logic Mode | Serial Bit Mode | |
| 1 | Control A | --- | TTL Output Hi/Lo | TTL Output Hi/Lo | |
| 2 | Control B | --- | TTL Output Hi/Lo | TTL Output Hi/Lo | |
| 3 | Control C | --- | TTL Output Hi/Lo | Strobe | |
| 4 | Control D | --- | TTL Output Hi/Lo | Serial Data | |
| 5 | Control I | --- | TTL Input Hi/Lo | TTL Input Hi/Lo | |
| 6 | Gnd | --- | Gnd | Gnd | |
| 7* | -15 Vdc $\pm 7\%$ | 150 ma | --- | --- | |
| 8* | +5 Vdc $\pm 5\%$ | 150 ma | --- | --- | |
| 9* | +15 Vdc $\pm 5\%$ | 150 ma | --- | --- | |
| * Total current drawn from the +15 Vdc on the PROBE POWER and the AUX INTERFACE cannot exceed 150 mA. Total current drawn from the -12.6 Vdc on the PROBE POWER and the -15 Vdc on the AUX INTERFACE cannot exceed 150 mA. | | | | | |

| WEIGHT | |
|---------------------|----------|
| Receiver RF Section | 62.5 lb. |
| RF Filter Section | 46 lb. |

HP 8546A EMI Receiver

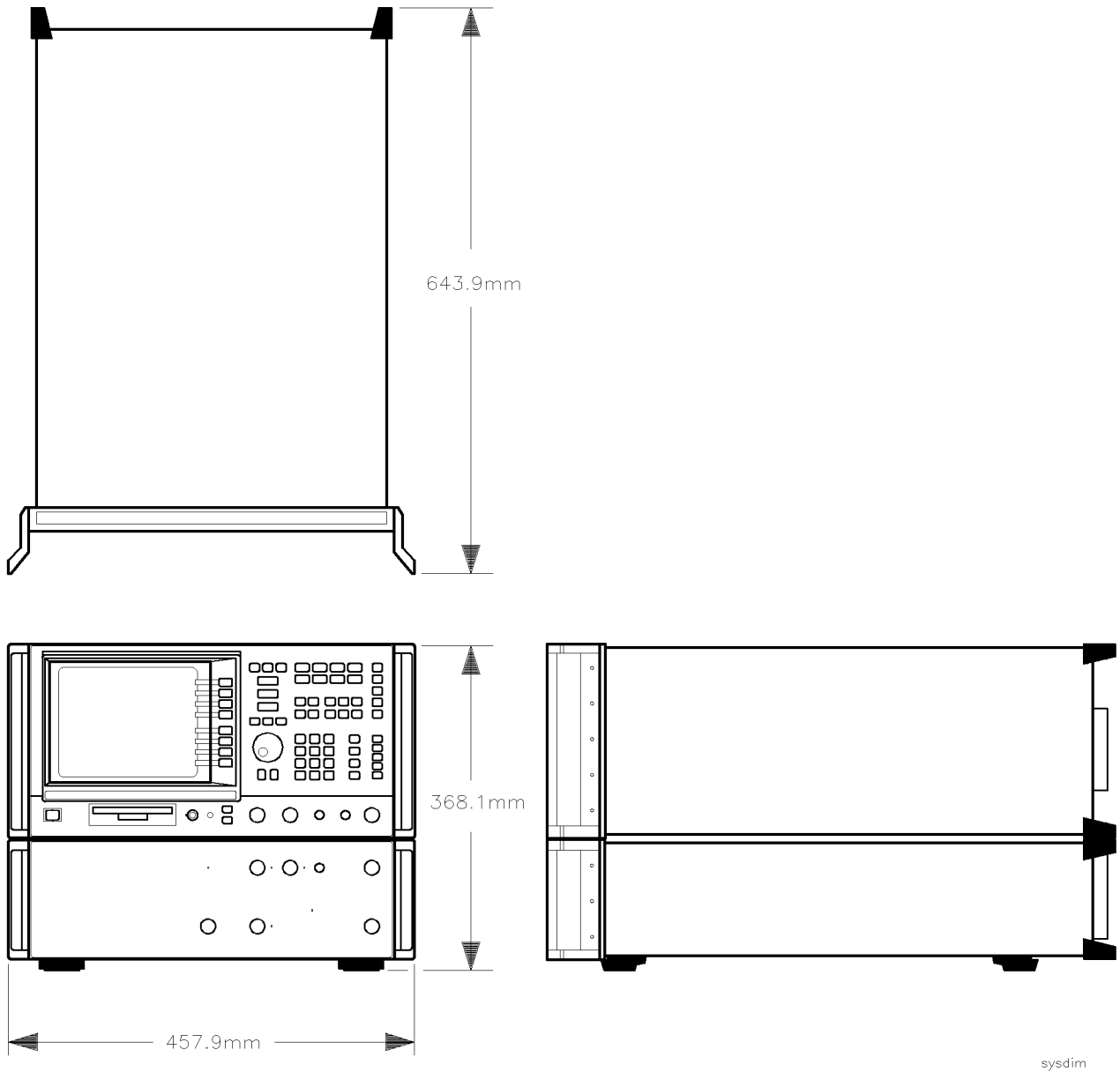

Figure 2-1. HP 8546A EMI Receiver Dimensions

General Specifications: HP 85462A Receiver RF Section

The specifications in this section apply to all functions autocoupled over the environmental conditions specified. All specifications apply after two hours of storage at a constant temperature within the operating temperature range, after the instrument has been operating for 60 minutes, and after CAL ALL and CAL YTF have been run.

| | |
|------------------------------|------------------|
| Temperature Range | |
| Operating* | 0 °C to +55 °C |
| Storage | -20 °C to +65 °C |
| * Disk drive +5 °C to +45 °C | |

| |
|---|
| EMI Compatibility |
| Receiver RF section radiated and conducted emissions performance is in compliance with CISPR Pub. 11/1990 Group 1 Class B. Receiver RF section susceptibility is in compliance with CISPR Pub. 16 at 3 V/m. |

| | |
|---------------|--------------------------------|
| Inputs | Type N, 50 Ω, 9 kHz to 6.5 GHz |
|---------------|--------------------------------|

| | |
|------------------|--|
| Detectors | |
| Measurement | Peak, Quasi-Peak, and Average. Quasi-Peak and Average time constants conform with CISPR Pub.16. |
| Overload | IF |

| | |
|----------------------|--|
| IF Bandwidths | |
| Measurement | 200 Hz, 9 kHz, and 120 kHz (6 dB bandwidths which conform to CISPR Pub.16) |
| Bandwidth Accuracy | 1 MHz, 6 dB bandwidth $\pm 10\%$ |
| Diagnostic | 30 Hz to 300 kHz, 3 dB bandwidths in 1,3,10 steps ($\pm 20\%$ characteristic), also 3 MHz and 5 MHz. Four-pole synchronously-tuned, approximately Gaussian shape. |

| | |
|-----------------------------|--|
| Averaging Bandwidths | 30 Hz to 1 MHz in 1,3,10 steps ($\pm 30\%$ characteristic), and 3 MHz. Post-detection single pole low-pass filters. 1,3,10 Hz digital filters with anti-aliasing |
|-----------------------------|--|

| | |
|-------------------------|---------------------------|
| Input Attenuator | |
| Range | 0 to 70 dB in 10 dB steps |

| | |
|-------------------------|---|
| Preamplification | 27 dB ± 1.5 dB ≤ 500 MHz, ± 4 dB > 500 MHz |
|-------------------------|---|

| | |
|---------------------|-----------|
| Demodulation | AM and FM |
|---------------------|-----------|

General Specifications: HP 85462A Receiver RF Section (continued)

| | |
|---|---|
| <p>Sweep Time Range Accuracy Sweep Trigger</p> | <p>20 ms to 100 s $\pm 3\%$ Free Run, Single, Line, Video, External</p> |
| <p>Disk Drive</p> | <p>Internal 3.5 inch disk drive, compatible with 1.44 MByte DOS and LIF format disks</p> |
| <p>Audible Noise</p> | <p><5.5 Bels power (ISODP 7779)</p> |
| <p>Power Requirements On Off</p> | <p>90 to 132 V rms, 47 to 440 Hz 198 to 264 V rms, 47 to 66 Hz Power consumption <500 VA; <180 W Power consumption <5 W</p> |
| <p>Environmental Conditions Environment Altitude Maximum Relative Humidity INSTALLATION CATEGORY II according to IEC 1010 POLLUTION DEGREE 2 according to IEC 664</p> | <p>Indoor Use Up to 15,000 feet (4,572 meters) 80% for temperatures up to 31 °C decreasing linearly to 50% relative humidity at 40 °C.</p> |

Tuning Specifications

| | |
|---------------------|--------------------|
| Tuning Range | |
| DC Coupled | 9 kHz to 6.5 GHz |
| AC Coupled | 100 kHz to 6.5 GHz |

| | |
|----------------------------|------------------------------|
| Frequency Reference | |
| Aging | $\pm 1 \times 10^{-7}$ /year |
| Settability | $\pm 1 \times 10^{-8}$ |
| Temperature Stability | $\pm 1 \times 10^{-8}$ |

| | |
|-----------------------------------|---|
| Frequency Readout Accuracy | \pm (frequency readout x frequency reference error * + span accuracy + 1% of span + 20% of IF Bandwidth + 100 Hz) † |
|-----------------------------------|---|

*Frequency reference error=(aging rate x period of time since last adjustment + initial achievable accuracy + temperature stability). See frequency characteristics.

†See "Drift" under "Stability" in frequency characteristics.

| | |
|-------------------|--------------------------------|
| Calibrator | |
| Frequency | 300 MHz fundamental |
| Accuracy | see frequency reference error* |

*Frequency reference error=(aging rate x period of time since last adjustment + initial achievable accuracy + temperature stability). See frequency characteristics.

Swept Frequency Specifications

| | |
|-------------------------------------|--|
| Frequency Span | |
| Range | 1 kHz to 6.5 GHz |
| Resolution | Four digits or 20 Hz, whichever is greater |
| Accuracy (single mixing band spans) | |
| Span \leq 10 MHz | $\pm 2\%$ of span + 10 Hz |
| Span $>$ 10 MHz | $\pm 3\%$ of span |

| | |
|----------------------------------|-------------------------------|
| Stability | |
| Noise sidebands* | |
| > 10 kHz offset from CW signal | ≤ -90 dBc/Hz |
| > 30 kHz offset from CW signal | ≤ -105 dBc/Hz |
| Residual FM | |
| 30 Hz IF BW, 30 Hz Averaging BW | ≤ 30 Hz pk-pk in 300 ms |
| 1 kHz IF BW, 1 kHz Averaging BW | ≤ 250 Hz pk-pk in 100 ms |
| System Related Sidebands | |
| > 30 kHz offset from CW signal | ≤ -65 dBc |

* 1 kHz IF BW, 30 Hz averaging BW, sample detector.

| | |
|---|---|
| Marker Count Accuracy\ddagger | |
| Frequency Spans \leq 10 MHz | $\pm(\text{marker frequency} \times \text{frequency reference error}^* + \text{counter resolution} + 100 \text{ Hz})$ |
| Frequency Spans $>$ 10 MHz | $\pm(\text{marker frequency} \times \text{frequency reference error}^* + \text{counter resolution} + 1 \text{ kHz})$ |
| Counter Resolution | |
| Frequency Spans \leq 10 MHz | Selectable from 10 Hz to 100 kHz |
| Frequency Spans $>$ 10 MHz | Selectable from 100 Hz to 100 kHz |

*Frequency reference error = (aging rate x period of time since last adjustment + initial achievable accuracy + temperature stability). See frequency characteristics.

\ddagger Marker level to displayed noise level > 25 dB, IF Bandwidth/Span ≥ 0.01 , Span ≤ 300 MHz.

Amplitude Specifications

Amplitude specifications do not apply for negative peak detector mode except as noted in “Amplitude Characteristics.”

| | |
|------------------------|--|
| Amplitude Range | -146 dBm to +30 dBm -39 dB μ V to +137 dB μ V |
|------------------------|--|

| | |
|--|-----------------------------------|
| Displayed Average Noise Level $f_o > 400$ kHz (input terminated, 0 dB attenuation, 30 Hz IF BW, 30 Hz Averaging BW, sample detection) | |
| Preamplifier On | -146 dBm (≤ -39 dB μ V) |
| Preamplifier Off | -125 dBm (≤ -18 dB μ V) |
| Characteristic Noise Figure | |
| Preamplifier On | 8 dB |
| Preamplifier Off | 24 dB |

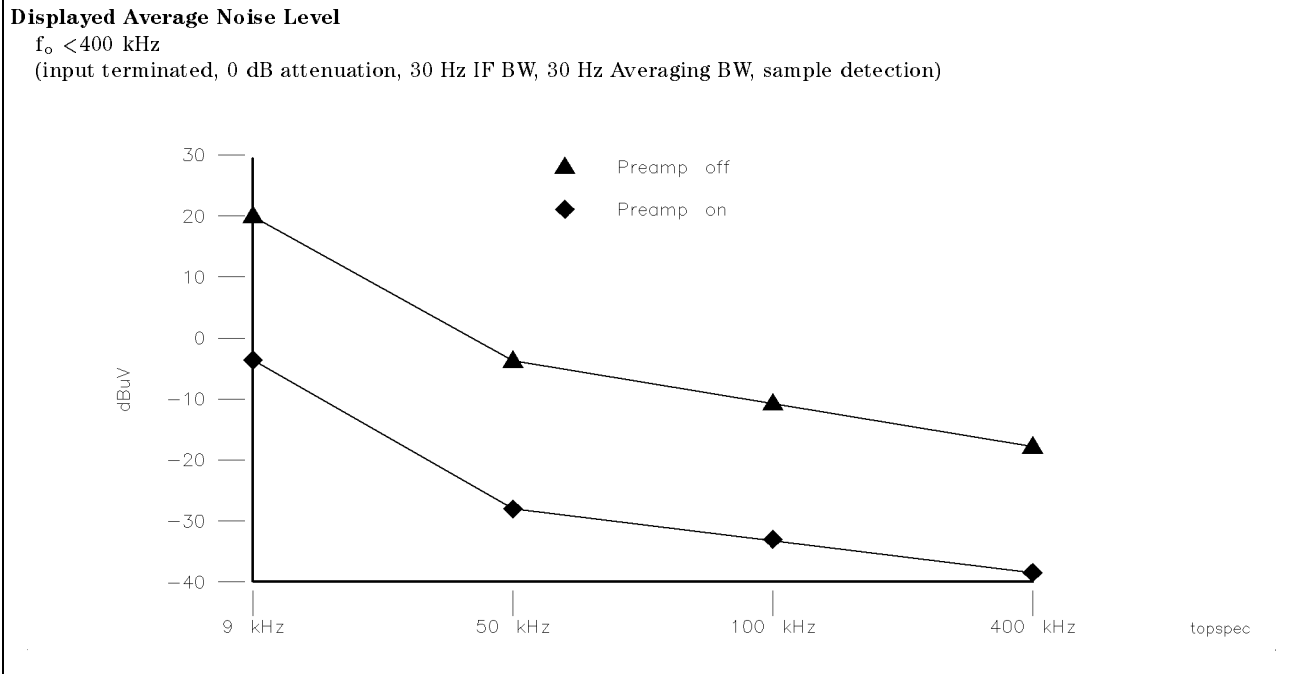

Amplitude Specifications (continued)

| | |
|---|-------------------------|
| Gain Compression* | |
| Specification | |
| $f_o > 10 \text{ MHz}$ | <0.5 dB |
| $200 \text{ kHz} \leq f_o \leq 10 \text{ MHz}$ | <0.75 dB |
| Characteristic 1 dB Compression Point | |
| $f_o > 10 \text{ MHz}$ | |
| Preamplifier On | 75 dB μ V (-32 dBm) |
| Preamplifier Off | 102 dB μ V (-5 dBm) |
| $9 \text{ kHz} \leq f_o \leq 10 \text{ MHz}$ | |
| Preamplifier On | 68 dB μ V (-39 dBm) |
| Preamplifier Off | 95 dB μ V (-12 dBm) |
| * Specifications derived from distortion measurements using a two-tone compression test with frequency offset of 30 MHz and -10 dBm total signal power at the input mixer. Total power at first mixer = input power - input atten + preamp gain. IF BW \leq 300 Hz, this applies only if signal separation \geq 4 kHz and signal amplitudes \leq Reference Level + 10 dB. | |

| | |
|--|--------------------------|
| Third Order Intercept Point† | |
| Specification | |
| $f_o > 200 \text{ kHz}$ | |
| Preamplifier On | 85 dB μ V (-22 dBm) |
| Preamplifier Off | 112 dB μ V (+5 dBm) |
| Characteristic Third Order Intercept | |
| $f_o > 10 \text{ MHz}$ | |
| Preamplifier On | 89 dB μ V (-18 dBm) |
| Preamplifier Off | 118 dB μ V (+11 dBm) |
| $9 \text{ kHz} \leq f_o \leq 10 \text{ MHz}$ | |
| Preamplifier On | 87 dB μ V (-20 dBm) |
| Preamplifier Off | 115 dB μ V (+8 dBm) |
| † Indicated specification was derived from a -70 dBc distortion product level with two -30 dBm CW signals at the first mixer and 50 kHz separation. Input mixer power = input power - input attenuation + preamp gain. | |

| | |
|---|--------------------------|
| Second Harmonic Intercept* | |
| $f_o > 200 \text{ kHz}$ | |
| Preamplifier On | 100 dB μ V (-9 dBm) |
| Preamplifier Off | 134 dB μ V (+27 dBm) |
| Characteristic Second Order Intercept | |
| Preamplifier On | |
| $f_o > 500 \text{ MHz}$ | 115 dB μ V (+8 dBm) |
| $9 \text{ kHz} \leq f_o \leq 500 \text{ MHz}$ | 108 dB μ V (+1 dBm) |
| Preamplifier Off | 144 dB μ V (+37 dBm) |
| * The indicated specification level was derived from a measured harmonic level of <-67 dBc and a -40 dBm CW signal at the input mixer. Input mixer power = input power - input attenuation + preamp gain. | |

Amplitude Specifications (continued)

| | |
|-------------------------------------|---------|
| Other Input Related Spurious | -65 dBc |
|-------------------------------------|---------|

30 kHz offset for -20 dBm tone at the mixer ≤ 2.9 GHz, $f_o > 10$ MHz.
 Input mixer power = input power - input attenuation + preamp gain.

| | |
|---|--------------------------|
| Residual Responses | |
| Input terminated, 0 dB attenuation, preamplifier on | |
| 150 kHz to 6.5 GHz | -8 dB μ V (-115 dBm) |
| 9 kHz to 150 kHz | +2 dB μ V (-105 dBm) |

| | |
|---------------------------------|---|
| Maximum Safe Input Level | |
| Average Continuous Power | |
| 9 kHz to 2.9 GHz | +30 dBm |
| 2.9 GHz to 6.5 GHz | +30 dBm (with 10 dB input attenuation) |
| Peak Pulse Power | |
| Preamplifier Off | +50 dBm (100 W) for 10 μ s pulse width and, 1% duty cycle, input atten ≥ 30 dB. |
| DC | 0 V (dc coupled) 50 V (ac coupled) |

| | |
|--------------------------|----------------------|
| Calibrator Output | |
| Amplitude | -20 dBm \pm 0.4 dB |

| | |
|---|---------------|
| Calibration Repeatability* | ± 0.15 dB |
| *Repeatability in the measured absolute amplitude of the CAL OUT signal at the reference settings after CAL FREQ and CAL AMP TD self-calibration. Absolute amplitude reference settings are: -20 dB reference level; 10 dB input attenuation; 300 MHz center frequency; 3 kHz IF BW; 300 Hz averaging BW; linear scale; 50 kHz span; coupled sweep time; reference level positioned at the top graticule; corrections on; and sample detection. | |

| | |
|----------------------|--|
| Display Range | |
| Log Scale | 0 to -66 dB from Reference Level is calibrated 0.1, 0.2, 0.5 dB/division and 1 to 20 dB/division in 1dB steps; eight divisions displayed |
| Linear Scale | Eight divisions |
| Scale Units | dBm, dBmV, dB μ V, V, W |

| | |
|----------------------------------|--|
| Marker Readout Resolution | 0.05 dB for log scale 0.05% of reference level for linear scale |
|----------------------------------|--|

Amplitude Specifications (continued)

| | |
|------------------------|------------------------------------|
| Reference Level | |
| Range | |
| Log Scale | -146 dBm to +30 dBm |
| Linear Scale | -126 dBm to +30 dBm |
| Resolution | |
| Log Scale | ±0.01 dB |
| Linear Scale | ±0.12% of Reference Level |
| Accuracy* | |
| 0 dBm to -59.9 dBm | ±(0.3 dB + 0.01 x dB from -20 dBm) |
| -60 dBm and below | |
| 1 kHz to 3 MHz IF BW | ±(0.6 dB + 0.01 x dB from -20 dBm) |
| 30 Hz to 300 Hz IF BW | ±(0.7 dB + 0.01 x dB from -20 dBm) |

* Referenced to -20 dBm reference level, 10 dB input attenuation, at a single frequency, in a fixed IF BW with preamplifier off. With preamplifier on, subtract preamplifier gain from all reference levels.

| | |
|--------------------------------|-----------------------------|
| Linear to Log Switching | ±0.25 dB at reference level |
|--------------------------------|-----------------------------|

| | |
|--|--|
| Display Scale Fidelity | |
| Log Maximum Cumulative (0 to -66 dB from Reference Level) | |
| 3 kHz to 3 MHz IF Bandwidth | ±(0.3 dB + 0.01 x dB from Reference Level) |
| ≤ 1 kHz IF Bandwidth | ±(0.4 dB + 0.01 x dB from Reference Level) |
| Log Incremental Accuracy (0 to -56 dB from Reference Level) | ±0.4 dB/4 dB |
| Linear Accuracy | ±3% of Reference Level |

| | |
|--|---------|
| IF Bandwidth Switching Uncertainty (at Reference Level, referenced to 3 kHz IF BW) | |
| 3 kHz to 3 MHz | ±0.4 dB |
| 1 kHz | ±0.5 dB |
| 30 Hz to 300 Hz | ±0.6 dB |

HP 85462A Receiver RF Section

| Flatness (dc coupled, 10 dB input attenuation) | Absolute* | Relative† |
|--|------------------|------------------|
| 9 kHz to 2.9 GHz | | |
| Preamplifier On | ±3.0 dB | ±2.0 dB |
| Preamplifier Off | ±1.5 dB | ±1.0 dB |
| 2.9 GHz to 6.5 GHz (preselector peaked) | | |
| Preamplifier On | ±2.5 dB | ±1.5 dB |
| Preamplifier Off | ±2.0 dB | ±1.5 dB |
| * Referenced to 300 MHz Calibrator. | | |
| † Referenced to midpoint between highest and lowest frequency response deviations. | | |

Tracking Generator Specifications

All Specifications apply over 0° C to 55° C. The receiver/tracking generator combination will meet its specification after 2 hours of storage at a constant temperature within the operating temperature range, 30 minutes after the combination is turned on, and after CAL ALL, CAL TRK GEN, and TRACKING PEAK have been run.

| | |
|---|---|
| Output Frequency Range | 9 kHz to 2.9 GHz |
| Warm-up time | 30 minutes |
| Output Power Level | |
| Range | -1 dBm to -66 dBm |
| Resolution | 0.1 dB |
| Absolute Accuracy (-20 dBm at 300 MHz) (25 °C ±10 °C) | ±0.75 dB |
| Vernier | |
| Range | 9 dB |
| Accuracy (25 °C ±10 °C) (-20 dBm at 300 MHz, 16 dB attenuation) | ±0.2 dB/dB |
| Incremental Cumulative | ±0.5 dB Total |
| Output Attenuator Range | 0 to 56 dB in 8 dB steps |
| Output Power Sweep | |
| Range | (-10 dBm to -1 dBm) - (source attenuator setting) |
| Resolution | 0.1 dB |
| Output Flatness (referenced to 300 MHz, -20 dBm) | |
| Frequency > 10 MHz | ±2 dB |
| Frequency ≤ 10 MHz | ±3 dB |
| Tracking Generator Feedthrough 400 kHz to 2.9 GHz | ≤ -110 dBm |

Tracking Generator Specifications (continued)

| | |
|--|----------------|
| Spurious Output (-1 dBm output) | |
| Harmonic Spurs from 300 kHz to 2.9 GHz TG output 300 kHz to 2.9 GHz | ≤ -25 dBc |
| Non-harmonic Spurs from 300 kHz to 2.9 GHz TG output 300 kHz to 2.0 GHz | ≤ -27 dBc |
| TG output 2.0 GHz to 2.9 GHz | ≤ -23 dBc |
| LO Feedthrough LO frequency 3.9214 GHz to 6.8214 GHz | ≤ -16 dBm |

Frequency Characteristics

These are not specifications. Characteristics provide useful but nonwarranted information about instrument performance.

| | |
|-----------------------------|---|
| Frequency Reference | |
| Aging | 5×10^{-10} /day, 7 day average after being powered on for seven days |
| Warm-up | 1×10^{-8} after 30 minutes on |
| Initial Achievable Accuracy | $\pm 2.2 \times 10^{-8}$ after being powered on for 24 hours |

| | |
|---|-----------------------------|
| Stability | |
| Drift (after warm-up at stabilized temperature) | <2 kHz/minute of sweep time |
| Frequency spans ≤ 10 MHz, free run trigger | |

Drift occurs only while receiver is sweeping frequency. Additional drift occurs when using Line, Video, or External trigger while waiting for the appropriate trigger.

Amplitude Characteristics

These are not specifications. Characteristics provide useful but nonwarranted information about instrument performance.

| Input Attenuator Uncertainty | |
|--|-----------|
| Attenuator Setting | |
| 0 dB | ± 0.2 dB |
| 10 dB | Reference |
| 20 dB | ± 0.4 dB |
| 30 dB | ± 0.5 dB |
| 40 dB | ± 0.7 dB |
| 50 dB | ± 0.8 dB |
| 60 dB | ± 1.0 dB |
| 70 dB | ± 1.0 dB |
| 10 dB Step Uncertainty (attenuator setting 10 to 70 dB) | ± 0.8 dB |
| Repeatability | ±0.05 dB |

| Unpeaked Frequency Response (dc coupled) (without preselector peaking, span ≤50 MHz, 10 dB input attenuation) | Absolute* | Relative† |
|--|-----------------|-----------|
| | 2.75 to 6.5 GHz | |
| Preamplifier On | ±3 dB | ±1 dB |
| Preamplifier Off | ±2 dB | ±1 dB |

* Referenced to 300 MHz CAL OUT.
† Referenced to midpoint between highest and lowest frequency response deviations.

| AC Coupled Insertion Loss‡ | |
|----------------------------|---------------------------|
| 100 kHz to 300 kHz | 0.7 dB |
| 300 kHz to 1 MHz | 0.2 dB |
| 1 MHz to 100 MHz | 0.07 dB |
| 100 MHz to 2.9 GHz | 0.05 dB + (0.06 × F)** dB |
| 2.9 GHz to 6.5 GHz | 0.05 dB + (0.13 × F)** dB |

‡ Referenced to dc coupled mode.
** F = frequency in GHz.

| Marker Readout Resolution (digitizing resolution) | |
|--|----------------------------|
| Log Scale | ±0.31 dB |
| Linear Scale | |
| Frequency ≤1 GHz | ±0.59 % of Reference Level |
| Frequency ≥1 GHz | ±1.03 % of Reference Level |

Amplitude Characteristics (continued)

| FM Demodulation | |
|------------------------|--|
| Input Level | $>(-60 \text{ dBm} + \text{attenuator setting})$ |
| Signal Level | 0 to -30 dB below reference level |
| FM Offset | 400 Hz nominal |
| FM Deviation (FM GAIN) | |
| Resolution | 1 kHz/volt nominal |
| Range | 10 kHz/volt to 1 MHz/volt |
| Bandwidth (6 dB) | $\text{FM Deviation} \div 2$ |
| FM Linearity | $\leq 1\%$ of FM deviation + 290 Hz |

Tracking Generator Characteristics

| | |
|--|-------------------------------|
| Tracking Drift Usable in a 1 kHz IF Bandwidth after a 5 minute warm-up | 1.5 kHz/5 minutes |
| RF Power Off Residuals 9 kHz to 2.9 GHz | < -120 dBm |
| Dynamic Range (Difference between maximum power out and tracking generator feedthrough) | > 109 dB |
| Output Attenuator Repeatability 300 kHz to 300 MHz 300 MHz to 2.0 GHz 2.0 GHz to 2.9 GHz | ±0.1 dB ±0.2 dB ±0.3 dB |
| Output VSWR 0 dB attenuation 8 dB attenuation | <3.0:1 <1.5:1 |

Physical Characteristics

| Front Panel Inputs and Outputs | |
|-----------------------------------|---|
| Input | Type N female, 50 Ω nominal |
| Calibrator Output | Type N female, 50 Ω nominal |
| Tracking Generator Output | Type N female, 50 Ω nominal |
| Probe Power* Voltage / Current | + 15 Vdc \pm 7% at 150 mA max. – 12.6 Vdc \pm 10% at 150 mA max. |
| Earphone Jack | 1/8 inch monaural jack |
| External ALC | Negative Detector |

* Total current drawn from the + 15 Vdc on the PROBE POWER and the AUX INTERFACE connectors cannot exceed 150 mA. Total current draw from the – 12.6 Vdc on the PROBE POWER and the – 15 Vdc on the AUX INTERFACE connectors cannot exceed 150 mA.

| Rear Panel Inputs and Outputs | |
|-------------------------------|------------------------|
| 10 MHz REF OUTPUT | |
| Connector | BNC female |
| Impedance | 50 Ω |
| Output Amplitude | >0 dBm |
| EXT REF IN | |
| Connector | BNC female |
| Input Amplitude Range | –2 dBm to + 10 dBm |
| Frequency | 10 MHz |
| AUX IF OUT | |
| Connector | BNC female |
| Frequency | 21.4 MHz |
| Amplitude Range | – 10 dBm to – 60 dBm |
| Impedance | 50 Ω |
| AUX VIDEO OUT | |
| Connector | BNC female |
| Amplitude Range | 0 to 1 V (uncorrected) |

HP 85462A Receiver RF Section

Physical Characteristics (continued)

| Rear Panel Inputs and Outputs (continued) | |
|---|---|
| EXT KEYBOARD | Interface compatible with HP part number C1405 Option ABA and most IBM/AT non auto-switching keyboards. |
| EXT TRIG INPUT Connector Trigger Level | BNC female Positive edge initiates sweep in EXT TRIG mode (TTL) |
| LO OUTPUT Connector Impedance Frequency Range | SMA female (must be terminated in 50 Ω when not used) 50 Ω 3.0 to 6.8214 GHz |
| HI-SWEEP IN/OUT (input/output 85462A) Connector Output Input | SMA female High = sweep, Low = retrace (TTL) Open collector, low stops sweep |
| SWEEP INPUT / OUTPUT (output 85462A) Connector Output | SMA female 0 to +10 V ramp |
| REMOTE INTERFACE (85462A) | HP-IB (RS-232 optional) |
| MONITOR OUTPUT | R, G, B (composite video on G) 25 kHz horizontal rate 60 Hz vertical rate |

AUX INTERFACE

Connector Type: 9-pin subminiature D

Connector Pinout:

| Pin # | Function | Current | Logic Mode | Serial Bit Mode |
|-------|------------------|---------|------------------|------------------|
| 1 | Control A | --- | TTL Output Hi/Lo | TTL Output Hi/Lo |
| 2 | Control B | --- | TTL Output Hi/Lo | TTL Output Hi/Lo |
| 3 | Control C | --- | TTL Output Hi/Lo | Strobe |
| 4 | Control D | --- | TTL Output Hi/Lo | Serial Data |
| 5 | Control I | --- | TTL Input Hi/Lo | TTL Input Hi/Lo |
| 6 | Gnd | --- | Gnd | Gnd |
| 7* | -15 Vdc \pm 7% | 150 ma | --- | --- |
| 8* | +5 Vdc \pm 5% | 150 ma | --- | --- |
| 9* | +15 Vdc \pm 5% | 150 ma | --- | --- |

* Total current drawn from the +15 Vdc on the PROBE POWER and the AUX INTERFACE cannot exceed 150 mA. Total current drawn from the -12.6 Vdc on the PROBE POWER and the -15 Vdc on the AUX INTERFACE cannot exceed 150 mA.

| WEIGHT | |
|---------------------|----------|
| Receiver RF Section | 62.5 lb. |

HP 85462A Receiver RF Section

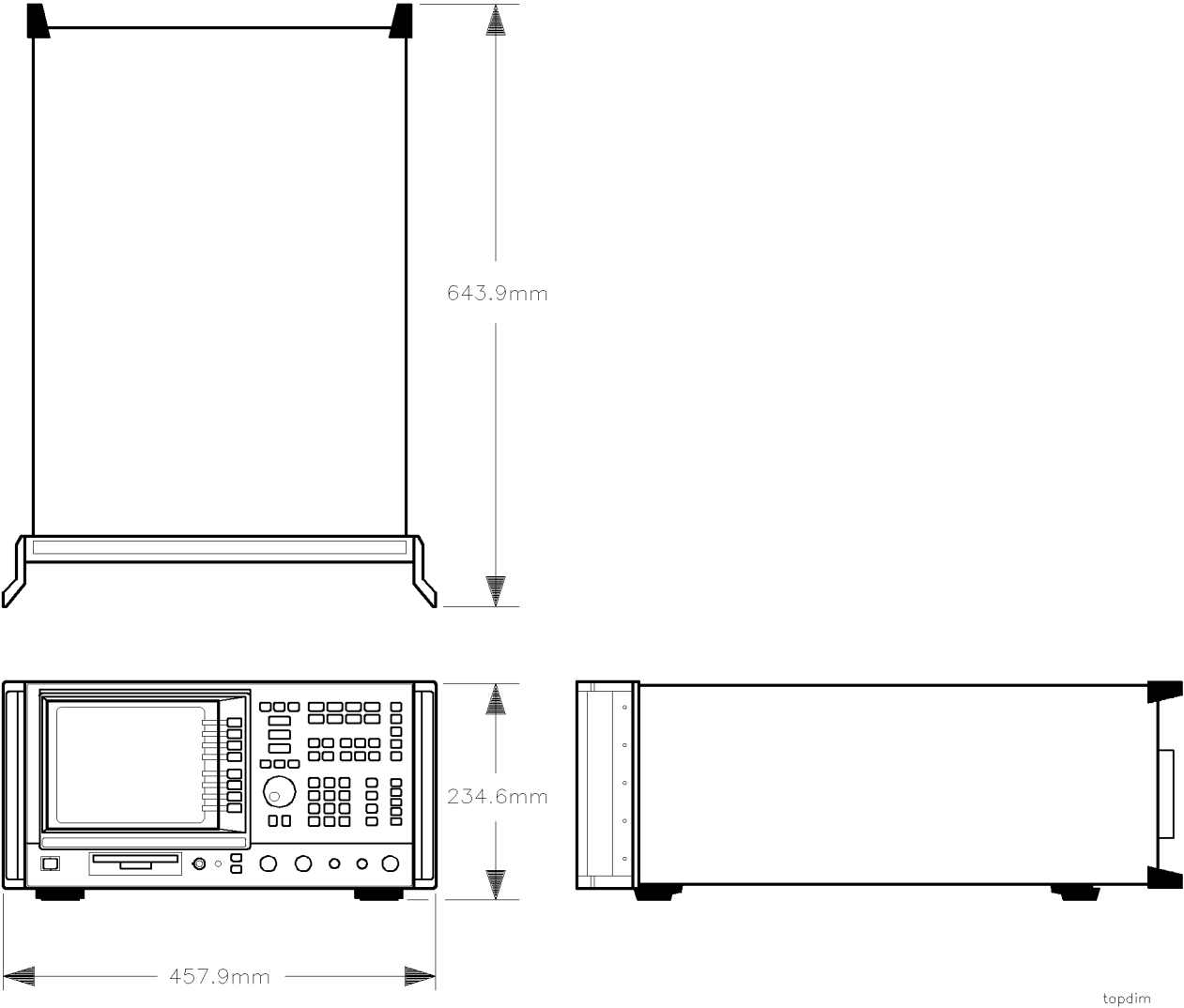

Figure 2-2. HP 85462A Receiver RF Section Dimensions

Regulatory Information

The information on the following page applies to the HP 8546A EMI receiver and HP 85462A receiver RF section.

DECLARATION OF CONFORMITY

according to ISO/IEC Guide 22 and EN 45014

Manufacturer's Name: Hewlett-Packard Co.

Manufacturer's Address: Santa Rosa Systems Division
1400 Fountaingrove Parkway
Santa Rosa, CA 95403-1799
USA

declares that the product

Product Name: EMI Receiver

Model Number: HP 8542E, HP 85420E, HP 85422E,
HP 8546A, HP 85460A, HP 85462A

Product Options: This declaration covers all options of the
above product.

conforms to the following Product specifications:

Safety: IEC 1010-1:1990+A1 / EN 61010-1:1993
CAN/GSA-C22.2 No. 1010.1-92

EMC: CISPR 11:1990/EN 55011:1991 Group 1, Class B
IEC 801-2:1984/EN 50082-1:1992 4 kV CD, 8 kV AD
IEC 801-3:1984/EN 50082-1:1992 3 V/m, 27-500 MHz
IEC 801-4:1988/EN 50082-1:1992 0.5 kV Sig. Lines, 1 kV Power Lines

Supplementary Information:

The product herewith complies with the requirements of the Low Voltage Directive 73/23/EEC and the EMC Directive 89/336/EEC.

Santa Rosa, California, USA 11 Sept 1995

Dixon Browder/Quality Manager

European Contact: Your local Hewlett-Packard Sales and Service Office or Hewlett-Packard GmbH, Department ZQ/Standards Europe, Herrenberger Strasse 130, D-71034 Böblingen, Germany (FAX +49-7031-14-3143)

Notice for Germany: Noise Declaration

LpA < 70 dB
am Arbeitsplatz (operator position)
normaler Betrieb (normal position)
nach DIN 45635 T. 19 (per ISO 7779)

Key Menus

This chapter contains the key menu diagrams for the EMI receiver and receiver RF section. Each diagram is arranged alphabetically according to the front-panel key name.

User Defined Keys

The top two softkeys are user-definable keys that remain the same regardless of the key menu selected. The default softkey definitions are:

- **Last Hrd Key Menu** toggles between the lowest level accessed on the last two hardkey menus selected. (toggles between the lowest level menu accessed by the last two hardkeys previously selected?)
- **SPAN** duplicates the SPAN softkey located under the **SPAN** key.

To define a user-definable softkey, use the **DEFINE USER KEY** on the third page of the SETUP menus. For more information on the user-defined keys, refer to Chapter 12, "User-Definable Softkeys," of the *EMI Receiver Series User's Guide*.

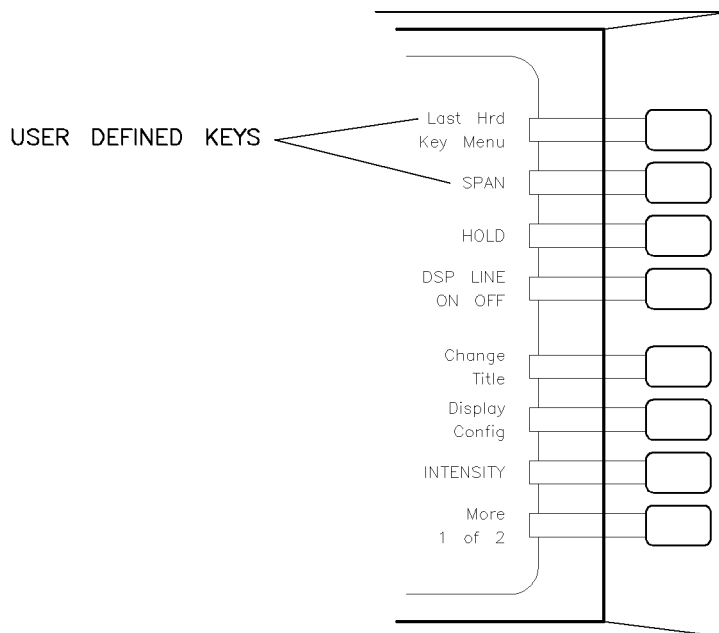

userdef

AMPLITUDE

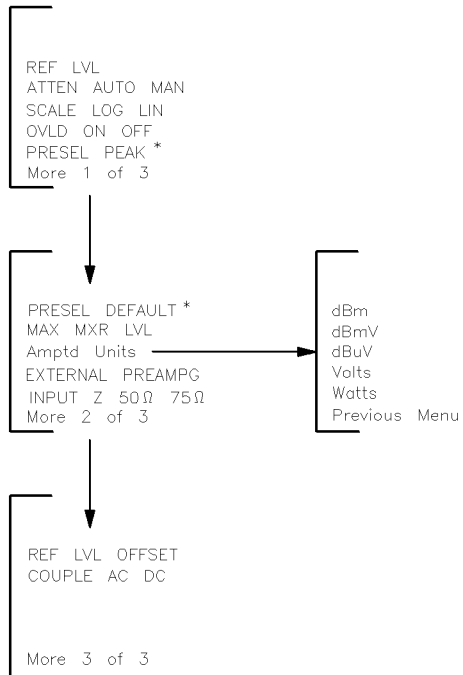

* Available only for an HP 8546A or an HP 85462A.

amplitud

AUTO COUPLE

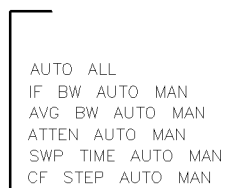

autocoup

AUTO RANGE

autorang

AUX CTRL

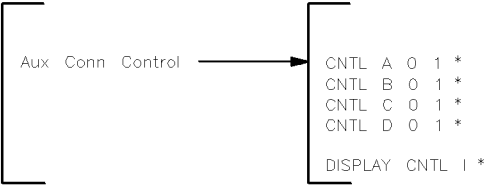

* Available only for a standalone receiver RF section.

auxctrl

AVERAGE

average

BW

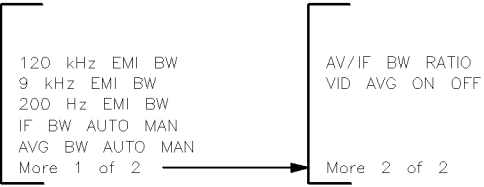

bw

CALIBRATE

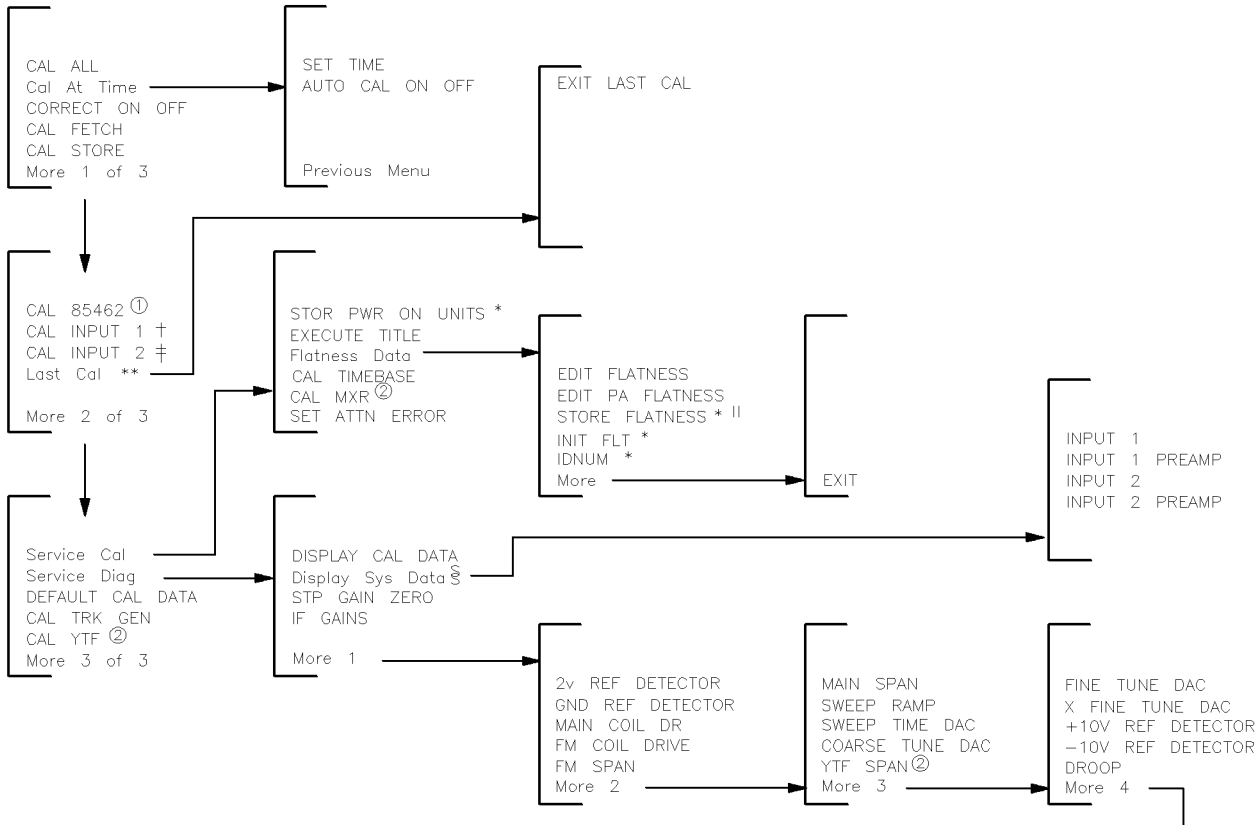

* For service use only.

† Softkey changes to CAL FREQ for a standalone receiver RF section.

‡ Softkey changes to CAL AMP for a standalone receiver RF section.

§ Softkey changes to DACS for a standalone receiver RF section.

|| Only appears when EDIT FLATNESS or EDIT PA FLATNESS are pressed.

** Available only for an EMI receiver.

① Softkey changes to CAL 85422 for an HP 85422E.

② Available only for an HP 8546A or an HP 85462A.

calbrate

CAL CHECK

calcheck

CONFIG

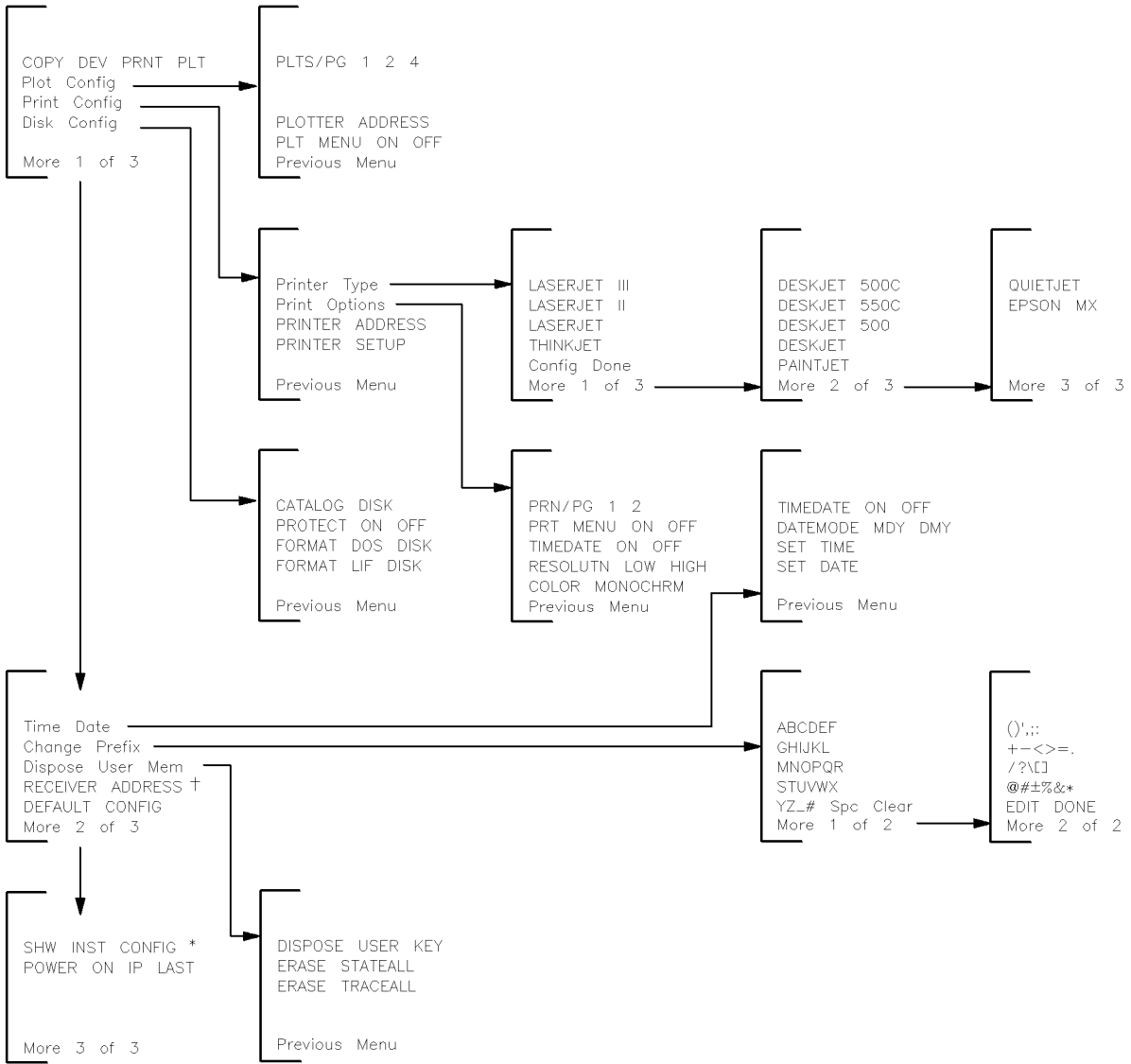

* When pressed, softkey changes to EXIT SHOW.
 † With Option 023, softkey is BAUD RATE.

config

COPY

copymenu

DEMODO

ON/OFF

SELECT

DEMODO ON OFF
DEMODO AM FM
SPEAKER ON OFF
SQUELCH
FM GAIN
DWELL TIME

demod

DISPLAY hardkey—in RECEIVER mode only

The DISPLAY hardkey has different Limit Lines softkey menus between the receiver and signal analysis modes.

DISPLAY

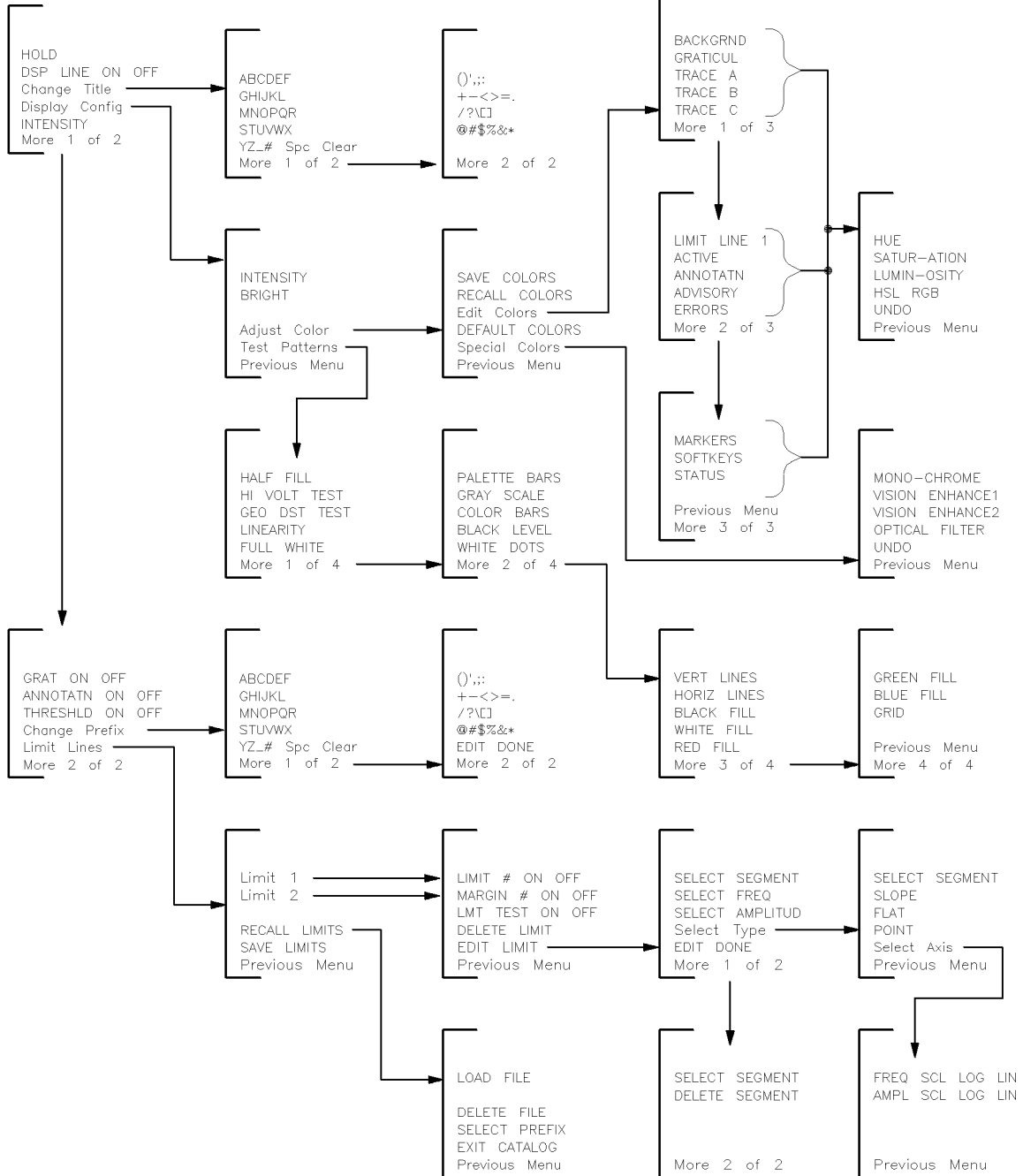

displayr

DISPLAY hardkey—in SIGNAL ANALYSIS mode only

The DISPLAY hardkey has different Limit Lines softkey menus between the receiver and signal analysis modes.

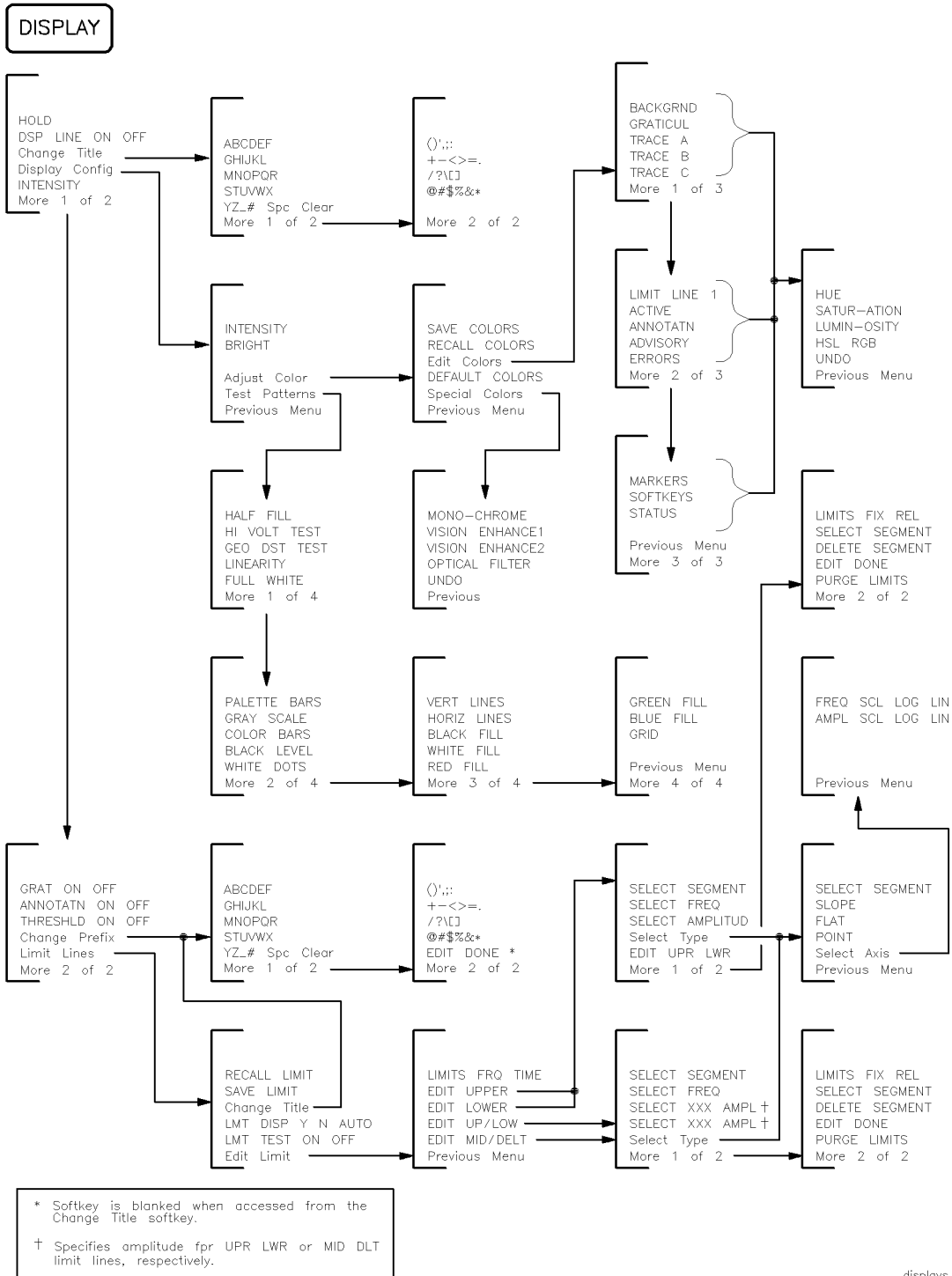

displays

FREQUENCY

CENTER FREQ
START FREQ
STOP FREQ
CF STEP AUTO MAN
SWEEP LOG LIN
More 1 of 2

FREQ OFFSET
Band Lock †
LOGF SPD STD FAST
INPT LCK ON OFF*
More 2 of 2

0-2.9 Gz BAND 0 †
2.75-6.5 BAND 1 †
BND LOCK ON OFF †
Previous Menu

* Available only for an EMI receiver.

† Available only for an HP 8546A or an HP 85462A.

frequenc

INPUT

INPUT 1 9k-50M*
INPUT 2 20M-2.9G*
INPUT 2 1-6.5G †
INPUT 2 BYPASS*
VIEW CAL ON OFF

* Available only for an EMI receiver.

† Available only for an HP 8546A.

inputm

LINEARITY CHECK

linechk

**MEAS/
USER**

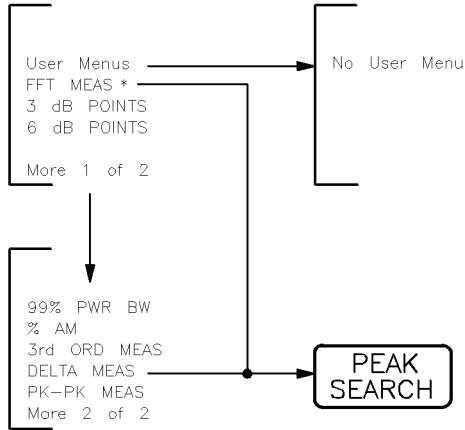

* Available only when LIN is selected for the SWEEP LOG LIN softkey.

measuser

MKR

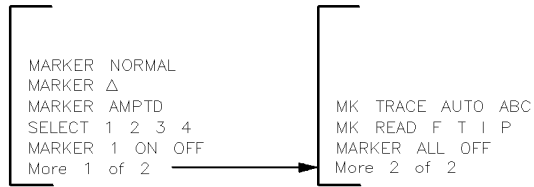

mkp

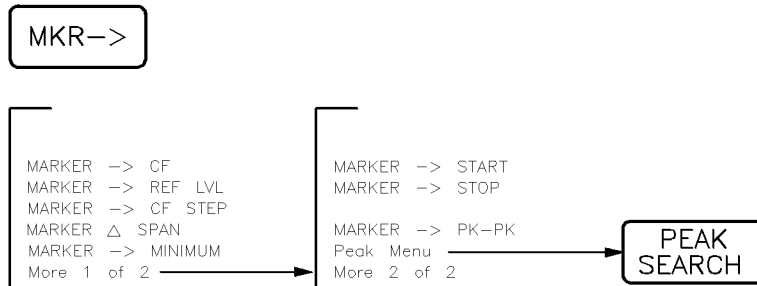

mkrright

MARKER FUNCTION

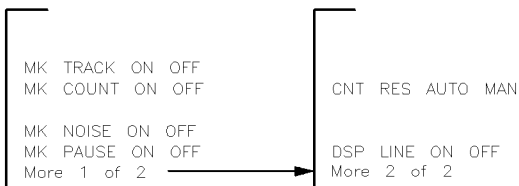

mkrfctn

MODE

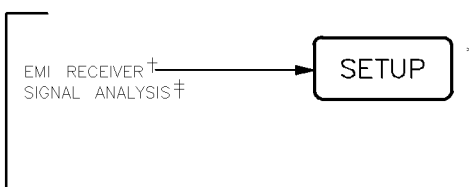

* Only occurs when switching from signal analysis mode to receiver mode.

† When EMI RECEIVER mode is active, pressing the MODE hardkey twice displays the softkey PRESET RECEIVER.

‡ When SIGNAL ANALYSIS mode is active, pressing the MODE hardkey twice displays the softkey PRESET SPECTRUM.

mode

OUTPUT

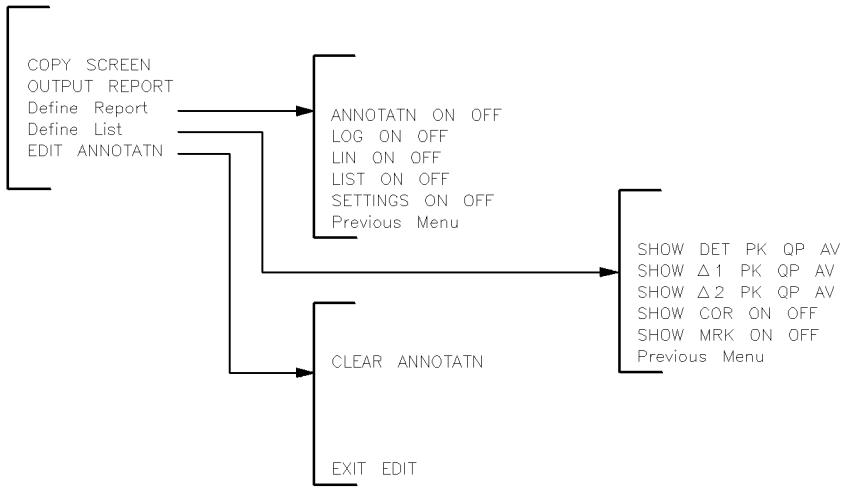

output

PEAK SEARCH

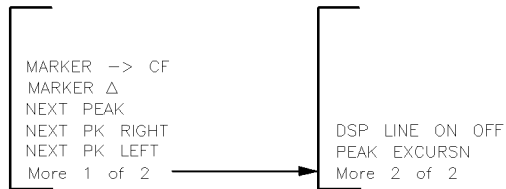

peaksrch

PREAMP

preamp

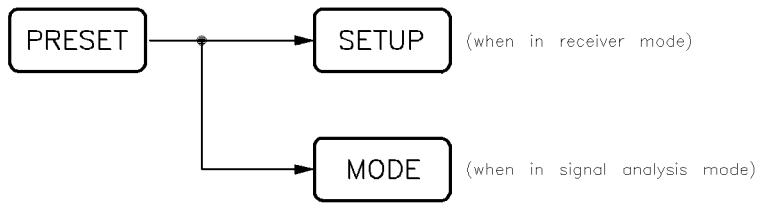

preset

QUASI-
PEAK

quasipk

RECALL

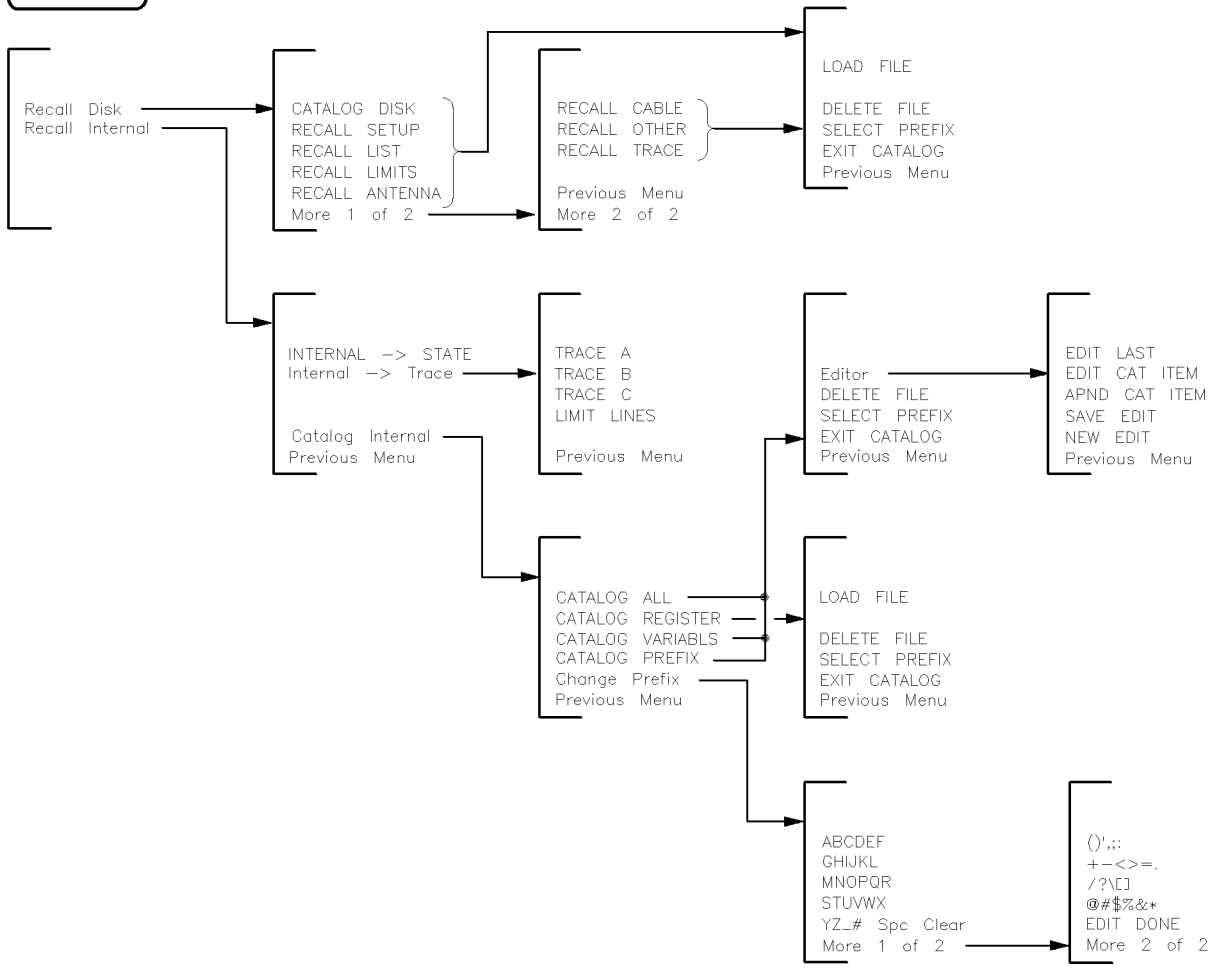

recall

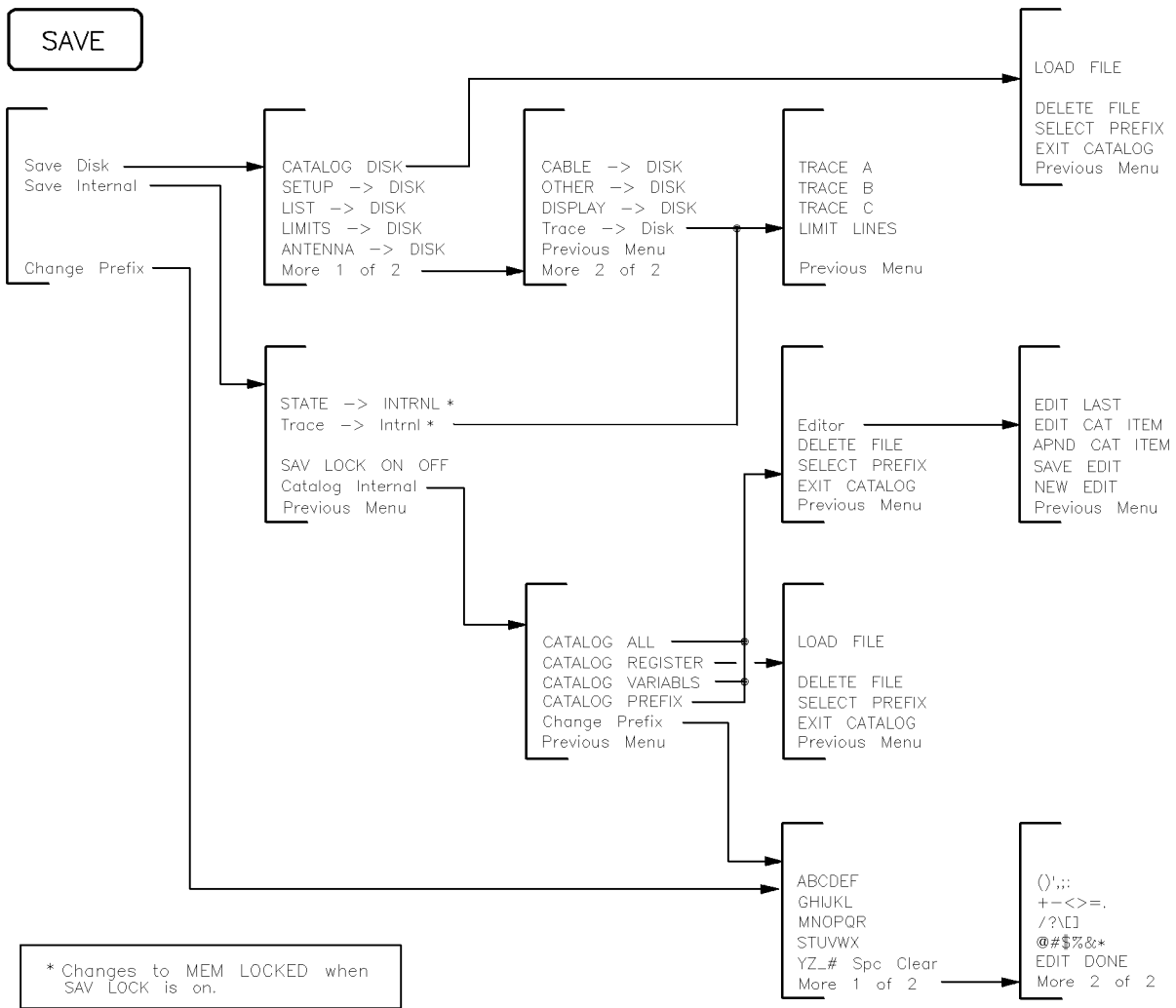

savemenu

SETUP hardkey—in RECEIVER mode only

The SETUP hardkey has different Limit Lines softkey menus between the receiver and signal analysis modes.

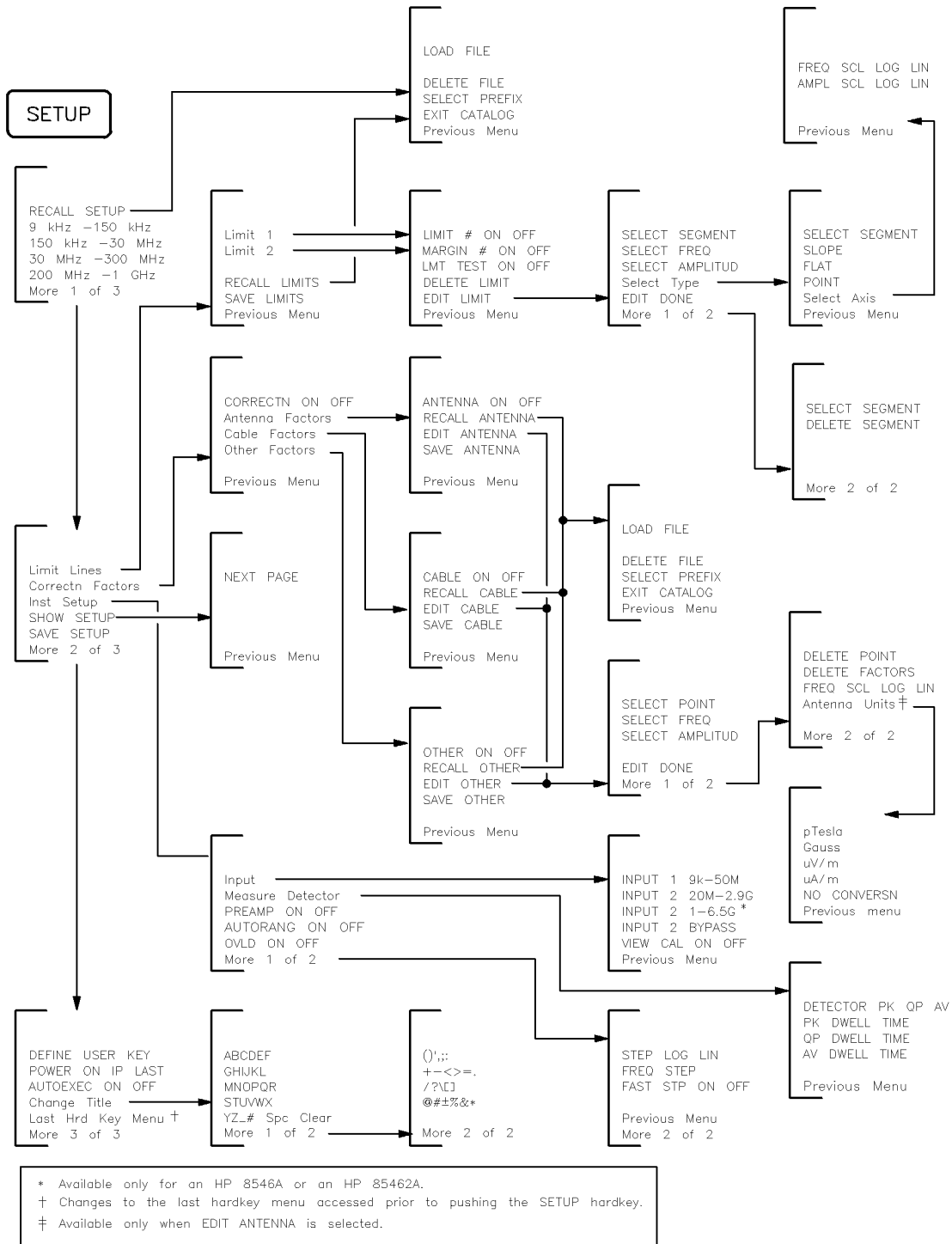

setupr

SETUP hardkey—in SIGNAL ANALYSIS mode only

The SETUP hardkey has different Limit Lines softkey menus between the receiver and signal analysis modes.

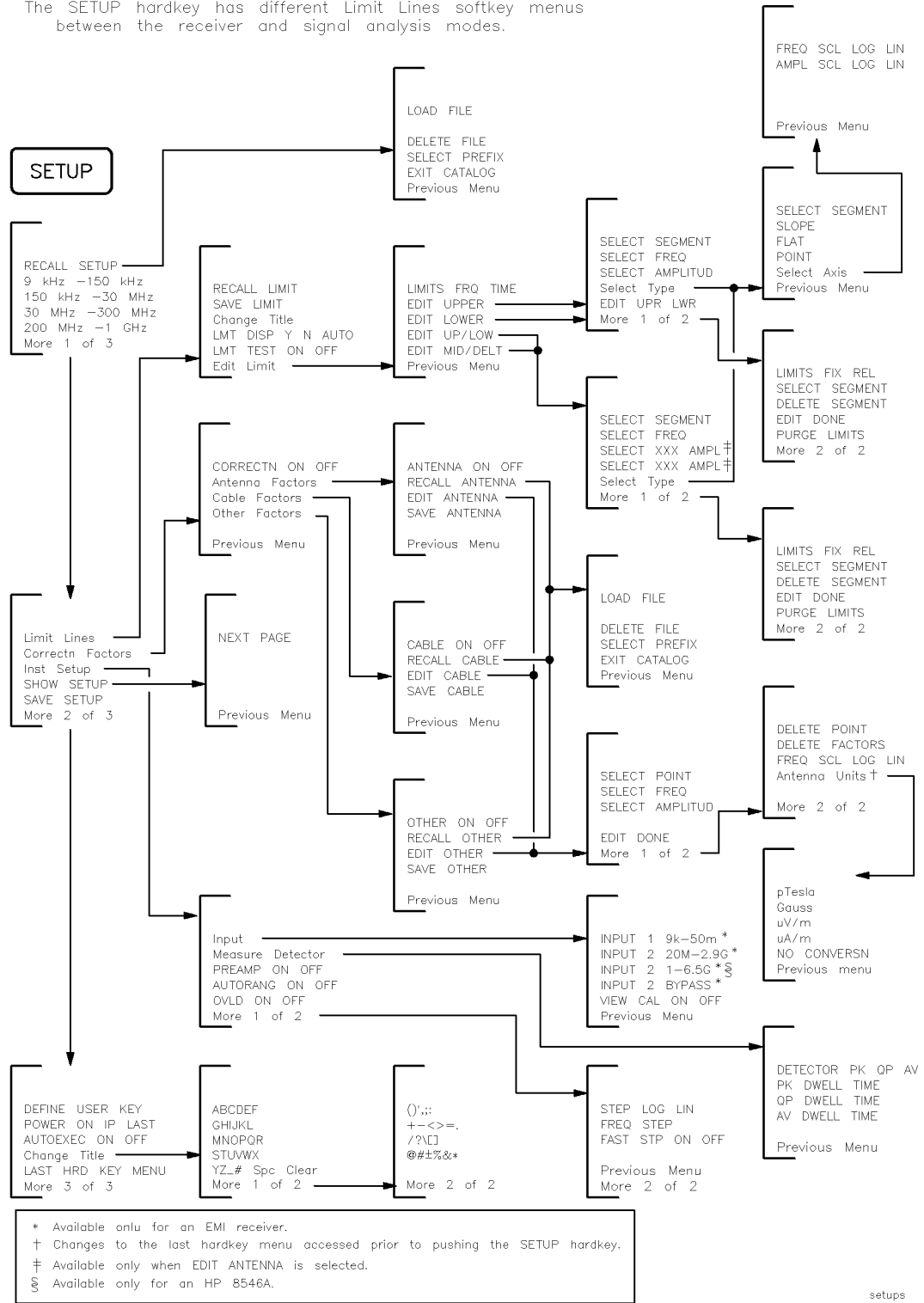

SINGLE

single

SPAN

SPAN
SPAN ZOOM
FULL SPAN
ZERO SPAN
LAST SPAN

spanmenu

SWEEP

SWP TIME AUTO MAN
SWEEP CONT SGL

SWEEP LOG LIN
LOGF SPD STD FAST *

* Available only when LOG is selected for the SWEEP LOG LIN softkey.

sweep

TEST hardkey—in RECEIVER mode only

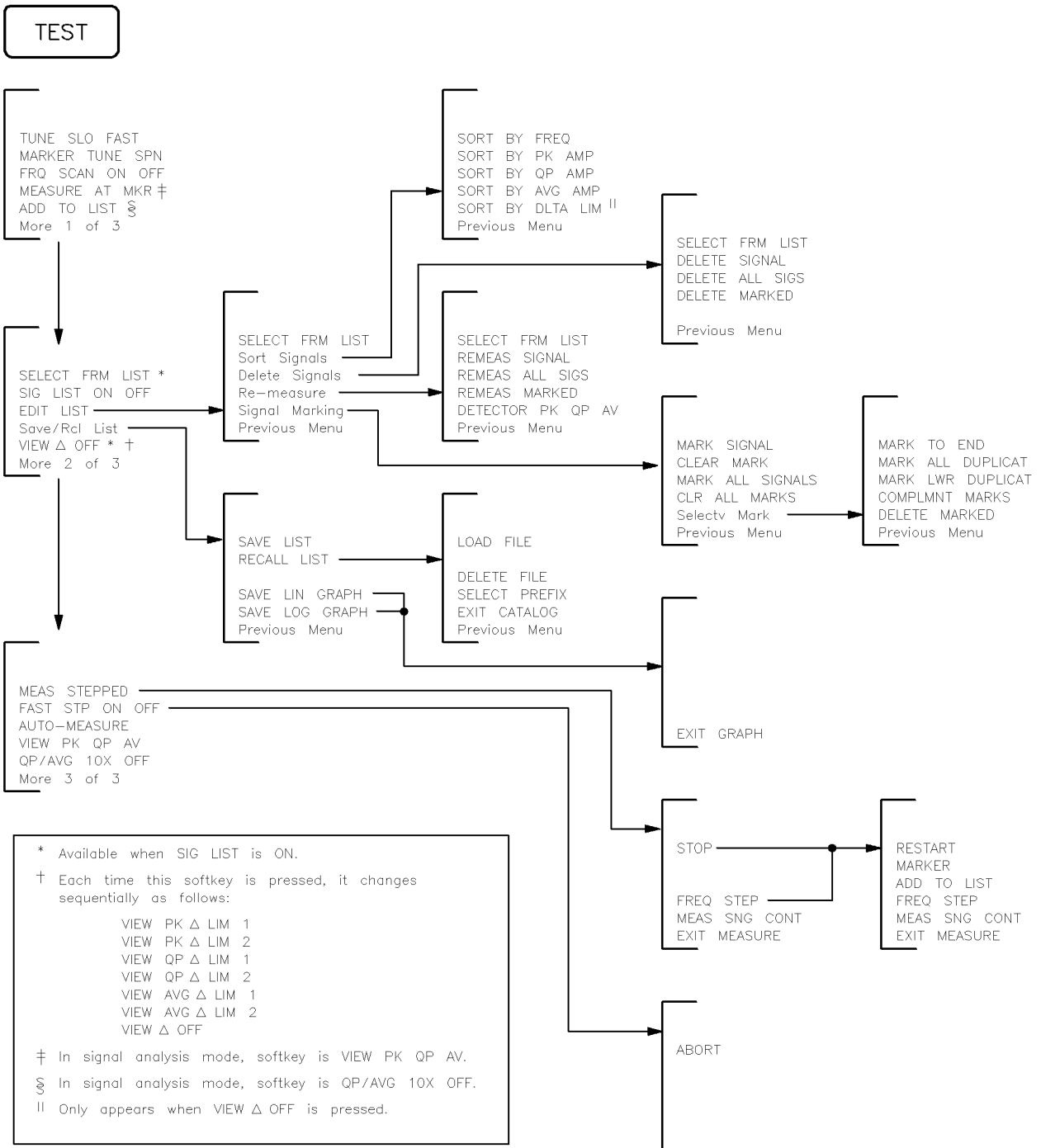

test

(with Trace A selected)

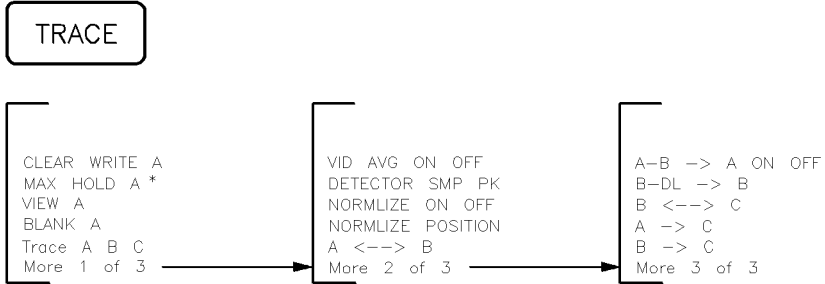

* With Trace C selected, softkey changes to MIN HOLD C.

tracem

TRACK GEN

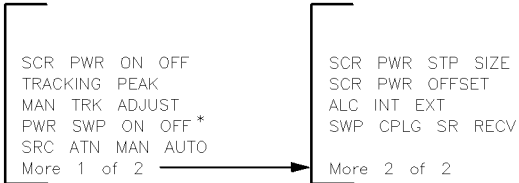

* Available only when LIN is selected for the SWEEP LOG LIN softkey.

trackgen

TRIG

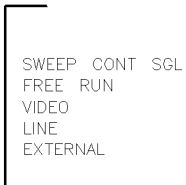

trig

WINDOWS

CTRL

ZONE CENTER
ZONE SPAN
ZONE PK RIGHT
ZONE PK LEFT
PEAK EXCURSN
WINDOWS OFF

NEXT

(If windows are on,
activates alternate
windows.)

ZOOM

(Toggles between
split-screen and
full-size display,
if windows are on.)

windows

Key Dictionary Reference

This chapter describes functions and controls of the instrument. The front-panel keys and softkey functions are listed alphabetically followed by a complete and detailed description.

Brief descriptions for service functions have also been included in this chapter. However, for more detailed descriptions and information about the use of each function, refer to the respective service guide for your instrument. A listing of all service calibration and service diagnostic functions has been provided in the following “Service Functions” section.

All softkeys and their relationship to the front-panel keys are shown in Chapter 3.

Service Functions

Two types of functions are available for service use only:

- Service calibration functions.
- Service diagnostic functions.

These service functions are designed for service use only. However, brief descriptions for each function are provided in this chapter.

Service Calibration Functions

Service Cal accesses the following service calibration softkeys:

```
CAL MXR
CAL TIMEBASE
EDIT FLATNESS
EDIT PA FLATNESS
EXECUTE TITLE
EXIT
Flatness Data
IDNUM
INIT FLT
SET ATTN ERROR
STOR PWR ON UNITS
STORE FLATNESS
```

Service Diagnostic Functions

Service Diag accesses the following diagnostic softkeys:

```
φ LOCK ON OFF
+10V REF DETECTOR
-10V REF DETECTOR
2v REF DETECTOR
COARSE TUNE DAC
DACS
DISPLAY CAL DATA
Display Sys Data
DROOP
FINE TUNE DAC
FM COIL DRIVE
FM GAIN
FM OFFSET
FM SPAN
FREQ DIAG
FRQ DISC NORM OFF
GND REF DETECTOR
IF GAINS
MAIN COIL DR
MAIN SPAN
MIXER BIAS DAC
```

PRESEL DAC
QP DET ON OFF
QP GAIN ON OFF
QPD OFFSET
QPD RST ON OFF
STP GAIN ZERO
SWEEP RAMP
SWEEP TIME DAC
X FINE TUNE DAC
YTF DRIVER
YTF SPAN
YTF TUNE COARSE
YTF TUNE FINE

Key Functions

% AM

Softkey that determines the percent of amplitude modulation of the largest displayed signal and its two sidebands. The sidebands are assumed to be entirely from amplitude modulation. If there are differences in the sideband amplitude, the larger value is used. The measurement runs continuously, reexecuting at the end of each sweep.

All three signal must be displayed. The frequency spacing of the sideband signals must be the same within the span accuracy of the measurement. All of the signals must be greater than the peak excursion above the threshold. The amplitude scale may be either linear or logarithmic.

Key Path

(MEAS\USER) **More** **% AM**
1 of 2 **ON OFF**

Related Programming Command

none

φ LOCK
ON OFF

Softkey that turns off phase locking on the instrument. The counter is turned off so frequency correction is no longer done at the start of each sweep. Turning the phase locking off increases measurement speed, but it decreases frequency accuracy. This is a service diagnostic function and is for service use.

Key Path

(CALIBRATE) **More** **More** **Service**
1 of 3 2 of 3 **Diag** **More 1 ... More 4**
φ LOCK
ON OFF

Related Programming Command

none

$\mu\text{A}/\text{m}$

Softkey that selects $\mu\text{A}/\text{m}$ as the transducer conversion units for the antenna amplitude-correction factors.

Key Path

| | | | | |
|---------|----------|------------------------|---------|--------|
| More | Correctn | Antenna | EDIT | More |
| 1 of 3 | Factors | Factors | ANTENNA | 1 of 2 |
| Antenna | | | | |
| Units | | $\mu\text{A}/\text{m}$ | | |

Related Programming Command

XUNITS

$\mu\text{V}/\text{m}$

Softkey that selects $\mu\text{V}/\text{m}$ as the transducer conversion units for the antenna amplitude-correction factors.

Key Path

| | | | | |
|---------|----------|------------------------|---------|--------|
| More | Correctn | Antenna | EDIT | More |
| 1 of 3 | Factors | Factors | ANTENNA | 1 of 2 |
| Antenna | | | | |
| Units | | $\mu\text{V}/\text{m}$ | | |

Related Programming Command

XUNITS

0-2.9 Gz
BAND 0

For an HP 8546A/HP 85462A only.

Softkey that locks onto harmonic Band 0. Once 0-2.9Gz BAND 0 has been pressed only frequencies and spans that fall within this frequency band may be entered. The span is reduced automatically to accommodate a center frequency specified near the end of the band range.

If a start frequency is entered that is outside of the current band boundaries, it will be set to the nearest band edge instead. If a start frequency that is greater than the current stop frequency is entered, the (possibly modified) start frequency is used for both the start and the stop frequency; therefore, the span will be set to zero. If the start and stop frequencies specify too large a span, they will be modified.

If a stop frequency is entered that is outside of the current band boundaries, it will be set to the nearest band edge instead. If a stop frequency that is less than the current start frequency is entered, the (possibly modified) stop frequency will be used for both the start and stop frequency; therefore, the span will be set to zero.

The span will be modified if necessary to get the center frequency specified without crossing the band edges. The span will be limited as necessary to keep the start and stop frequencies within the band

edges without changing the center frequency. The maximum span allowed is 2.904 GHz.

Note

For this softkey function to work properly, the corresponding **INPUT** must first be selected.

Key Path

FREQUENCY More 1 of 2 Band Lock 0-2.9 Gz BAND 0

Related Programming Command

HNLOCK

**2v REF
DETECTOR**

Softkey that displays the output of the 2 V reference produced on the A16 processor/video assembly as a horizontal line at the top graticule. This is a service diagnostic function and is for service use only.

Key Path

CALIBRATE More 1 of 3 More 2 of 3 Service Diag More 1 2v REF DETECTOR

Related Programming Command

none

**2.75-6.5
BAND 1**

For an HP 8546A/HP 85462A only.

Softkey that locks onto harmonic Band 1. Once **2.75-6.5 BAND 1** has been pressed only frequencies and spans that fall within this frequency band may be entered. The span is reduced automatically to accommodate a center frequency specified near the end of the band range.

If a start frequency is entered that is outside of the current band boundaries, it will be set to the nearest band edge instead. If a start frequency that is greater than the current stop frequency is entered, the (possibly modified) start frequency is used for both the start and the stop frequency; therefore, the span will be set to zero. If the start and stop frequencies specify too large a span, they will be modified.

If a stop frequency is entered that is outside of the current band boundaries, it will be set to the nearest band edge instead. If a stop frequency that is less than the current start frequency is entered, the (possibly modified) stop frequency will be used for both the start and stop frequency; therefore, the span will be set to zero.

The span will be modified if necessary to get the center frequency specified without crossing the band edges. The span will be limited as necessary to keep the start and stop frequencies within the band

edges without changing the center frequency. The maximum span allowed is 3.6 GHz.

Note

For this softkey function to work properly, the corresponding **INPUT** must first be selected.

Key Path

FREQUENCY More Band 2.75-6.5
1 of 2 Lock BAND 1

Related Programming Command

HNLOCK

**3 dB
POINTS**

Softkey that initiates an automatic 3 dB bandwidth measurement on the highest peak displayed on screen.

Key Path

MEAS/USER 3 dB
POINTS

Related Programming Command

none

**3rd ORD
MEAS**

Softkey that initiates an automatic frequency and amplitude measurement on a third-order product. At least one of the fundamental tones and the third-order product must be displayed on the screen.

Key Path

MEAS/USER More 3rd ORD
1 of 2 MEAS

Related Programming Command

none

6 dB
POINTS

Softkey that initiates an automatic 6 dB bandwidth measurement on the highest peak displayed on the screen.

Key Path

6 dB
POINTS
(MEAS/USER)

Related Programming Command

none

9 kHz -
150 kHz

Softkey that presets the instrument to the predefined settings:

| | |
|------------------|---------------|
| Start frequency: | 9 kHz |
| Stop frequency: | 150 kHz |
| I.F. bandwidth: | 200 Hz |
| Reference level: | 70 dB μ V |
| Attenuation: | 10 dB |

Key Path

9 kHz -
150 kHz
(SETUP)

Related Programming Command

none

9 kHz
EMI BW

Softkey that allows a 6 dB intermediate frequency bandwidth of 9 kHz. This bandwidth is useful when performing electromagnetic interference (EMI) measurements.

Key Path

9 kHz
EMI BW
(BW)

Related Programming Command

none

+10V REF DETECTOR

Softkey that displays the output of the +10 V reference from the analog interface circuit board as a horizontal line at the top of the graticule. This is a service diagnostic function and is for service use only.

Key Path

CALIBRATE More More Service
1 of 3 2 of 3 Diag More 1 ... More 3
+10V REF
DETECTOR

Related Programming Command

none

-10V REF DETECTOR

Softkey that displays the output of the -10 V reference from the analog circuit board as a horizontal line at the bottom graticule. This is a service diagnostic function and is for service use only.

Key Path

CALIBRATE More More Service
1 of 3 2 of 3 Diag More 1 ... More 3
-10V REF
DETECTOR

Related Programming Command

none

30 MHz - 300 MHz

Softkey that presets the receiver to the predefined settings:

| | |
|------------------|---------------|
| Start frequency: | 30 MHz |
| Stop frequency: | 300 MHz |
| I.F. bandwidth: | 120 kHz |
| Reference level: | 80 dB μ V |
| Attenuation: | 10 dB |

Key Path

SETUP 30 MHz -
300 MHz

Related Programming Command

none

99% PWR
BW

Softkey that initiates an automatic measurement of the 99% power bandwidth of the largest signal displayed on the screen.

Key Path

More 99% PWR
(MEAS/USER) 1 of 2 BW

Related Programming Command

none

120 kHz
EMI BW

Softkey that allows a 6 dB intermediate frequency bandwidth of 120 kHz. This bandwidth is useful when performing electromagnetic interference (EMI) measurements.

Key Path

120 kHz
(BW) EMI BW

Related Programming Command

none

150 kHz -
30 MHz

Softkey that presets the instrument to the predefined settings:

| | |
|------------------|---------------|
| Start frequency: | 150 kHz |
| Stop frequency: | 30 MHz |
| I.F. bandwidth: | 9 kHz |
| Reference level: | 75 dB μ V |
| Attenuation: | 10 dB |

Key Path

150 kHz -
(SETUP) 30 MHz

Related Programming Command

none

200 Hz
EMI BW

Softkey that allows a 6 dB intermediate frequency bandwidth of 200 Hz. This bandwidth is useful when performing electromagnetic interference (EMI) measurements.

Key Path

200 Hz
(BW) EMI BW

Related Programming Command

none

200 MHz -
1 GHz

Softkey that presets the instrument to the predefined settings:

| | |
|------------------|---------------|
| Start frequency: | 200 MHz |
| Stop frequency: | 1 GHz |
| I.F. bandwidth: | 120 kHz |
| Reference level: | 80 dB μ V |
| Attenuation: | 10 dB |

Key Path

200 MHz -
(SETUP) 1 GHz

Related Programming Command

none

A<-->B

Softkey that exchanges the contents of the trace A register with the trace B register and puts trace A in view mode.

Key Path

More
(TRACE) 1 of 3 A<-->B

Related Programming Command

AXB

A - B -> A
ON OFF

Softkey that when ON is underlined, subtracts the data in trace B from the measured data in trace A. A minus sign (-) appears between the trace A status and the trace B status in the screen annotation while the function is active.

To deactivate this function, press **A - B -> A ON OFF** so that OFF is underlined. The A-B -> A and B-DL -> B functions are math functions. Unlike operations on dBm units, math functions operate on measurement units. Measurement units are used to format trace data for data within the graticule limits. The displayed amplitude of each element falls on one of 8000 vertical points with the value of 8000 being equal to the reference level. For log scale data, each point is equal to 0.01 dB. The peak of a signal equal to -10 dBm, or one division below the reference level, is equal to 7000 measurement units (8000 - 1000 = 7000). In linear mode, each point has a resolution of [reference level in volts/8000].

For example, if trace A contains amplitude values of -10 dBm and trace B contains amplitude values of -40 dBm, the result of the A - B -> A function would be -10.004 dBm if dBm units were used. Since measurement units are used for the A - B -> A function, the result of A - B -> A is -50 dBm (-10 dBm = 7000 measurement units, -40 dBm = 4000 measurement units; the result is 3000 measurement units, which is equal to -50 dBm).

Key Path

TRACE **More** **More** **A - B -> A**
1 of 3 **2 of 3** **ON OFF**

Related Programming Command

AMB

A -> C

Softkey that copies trace A into trace C.

Key Path

TRACE **More** **More** **A -> C**
1 of 3 **2 of 3**

Related Programming Command

none

ABCDEF

Softkey that accesses the softkey menu for selecting screen title characters A through F.

Key Access

(CONFIG), (DISPLAY), (RECALL), (SAVE), or (SETUP)

Related Programming Command

none

ABORT

Softkey that exits the Auto Measure function.

Key Path

(TEST) More 1 of 3 More 2 of 3 AUTO-MEASURE ABORT

Related Programming Command

none

ACTIVE

Softkey that displays the current settings of the display subsystem's color editor.

Key Path

(DISPLAY) Display Config Adjust Color Edit Colors More 1 of 3 ACTIVE

Related Programming Command

SETC

ADD TO LIST

Softkey that adds a signal to the internal signal list. The signal added is either for the last MEASURE AT MKR result or the measurement at the marker position after a stepped measurement.

Key Path

(TEST) ADD TO LIST

(TEST) More 1 of 3 More 2 of 3 MEAS STEPPED STOP ADD TO LIST

(TEST) More 1 of 3 More 2 of 3 MEAS STEPPED FREQ STEP ADD TO LIST

Related Programming Command

SIGADD

Adjust
Color

Softkey that accesses a menu used to adjust the color editor display subsystem.

Key Path

Display Adjust
Config Color
(DISPLAY)

Related Programming Command

SETC

ADVISORY

Softkey that activates the advisory portion of the display screen for color editing.

Key Path

Display Adjust Edit More
Config Color Colors 1 of 3 ADVISORY
(DISPLAY)

Related Programming Command

SETC

ALC
INT EXT

Softkey that activates internal (INT) leveling or external (EXT) leveling.

Key Path

More ALC
1 of 2 INT EXT
(TRACK GEN)

Related Programming Command

SRCALC

AMPL SCL
LOG LIN

Softkey that specifies whether the limit line is derived from a logarithmic or linear amplitude axis. Underline LIN to set the amplitude axis to linear or LOG to set the amplitude axis to logarithmic.

Key Path

Receiver mode

More Limit EDIT Select Select
1 of 2 Lines ... * LIMIT Type Axis
AMPL SCL
LOG LIN

More Limit EDIT Select Select
1 of 3 Lines ... * LIMIT Type Axis
AMPL SCL
LOG LIN

Signal analysis mode

More Limit Edit Select Select
1 of 2 Lines Limit ... † Type Axis
AMPL SCL
LOG LIN

More Limit Edit Select Select
1 of 3 Lines Limit ... † Type Axis
AMPL SCL
LOG LIN

* Either Limit 1 or Limit 2 can be used to complete the key path.

† Any of the following can be used to complete the key path:

EDIT UPPER, EDIT LOWER, EDIT UP/LOW, or EDIT MID/DELT.

Related Programming Command

LIMIAMPSCCL

AMPLITUDE

Hardkey that activates the reference level function and accesses the amplitude menu. The softkeys accessed when you press AMPLITUDE change reference level, input attenuation, vertical scale, mixer level, amplitude units, input impedance, and amplitude offset. Pressing AMPLITUDE accesses the preselector peaking and preselector default functions also.

Related Programming Command

none

**Amptd
Units**

Softkey that accesses a menu to select the desired amplitude units. Amplitude units can be selected by pressing, **dBm**, **dBmV**, **dBuV**, **Volts**, or **Watts**.

Key Path

AMPLITUDE **More** **Amptd**
1 of 3 **Units**

Related Programming Command

AUNITS

ANNOTATN

Softkey that activates the annotation portion of the display screen for color editing.

Key Path

DISPLAY **Display** **Adjust** **Edit** **More**
Config **Color** **Colors** 1 of 3 **ANNOTATN**

Related Programming Command

SETC

**ANNOTATN
ON OFF**

*As accessed from **DISPLAY**.*

Softkey that turns the screen annotation on or off. However, softkey annotation will remain on the screen. The screen annotation may not be required for prints or plots, or during remote operation. Refer to the **HOLD** softkey description regarding softkey annotation.

*As accessed from **OUTPUT**.*

Softkey that turns on or off the generation of a tabular listing of the screen annotation. The listing will be sent to the printer when **OUTPUT REPORT** is executed.

Key Path

DISPLAY **More** **ANNOTATN**
1 of 2 **ON OFF**

OUTPUT **Define** **ANNOTATN**
Report **ON OFF**

Related Programming Command

ANNOT

ANTENNA
-> DISK

Softkey that saves the current antenna amplitude-correction factors to a floppy disk. To save antenna data press, ANTENNA -> DISK . REGISTER # and PREFIX= are displayed on the screen. Use the data keys to enter the desired register number then press (ENTER). The message Saving to :FILENAME is displayed. The antenna data has now been saved to a disk.

Key Path

Save ANTENNA
(SAVE) Disk -> DISK

Related Programming Command

none

Antenna
Factors

Softkey that accesses a menu to turn on, recall, edit, or save antenna amplitude-correction factors. Antenna factors are conversion factors relating field strength to measured voltage.

Key Path

More Correctn Antenna
(SETUP) 1 of 3 Factors Factors

Related Programming Command

AMPCOR

ANTENNA
ON OFF

Softkey that turns on or off antenna amplitude-correction factors.

Key Path

More Correctn Antenna ANTENNA
(SETUP) 1 of 3 Factors Factors ON OFF

Related Programming Command

AMPCOR

Antenna Units

Softkey that accesses a menu of the transducer conversion units for the antenna-correction factors. This specifies the units of the physical attribute to which an antenna actually responds and which will be indicated on the display for reference level, display line level, threshold level, and marker readouts.

Key Path

| | | | | | |
|---------|---------|----------|---------|---------|--------|
| | More | Correctn | Antenna | EDIT | More |
| (SETUP) | 1 of 3 | Factors | Factors | ANTENNA | 1 of 2 |
| | Antenna | | | | |
| | Units | | | | |

Related Programming Command

XUNITS

APND CAT ITEM

Softkey that starts the DLP editor function and allows the highlighted item from the catalog of instrument memory to be added to the end of the item that is currently in the DLP editor memory of the instrument. If the item to be added will not fit in the available memory space, it will not be appended.

Key Path

| | | | | | |
|----------|----------|----------|-------|--------|----------|
| | Recall | Catalog | | APND | |
| (RECALL) | Internal | Internal | ... * | Editor | CAT ITEM |
| | Save | Catalog | | APND | |
| (SAVE) | Internal | Internal | ... * | Editor | CAT ITEM |

* Any of the following can be used to complete the key path:
CATALOG ALL , CATALOG PREFIX , or CATALOG VARIABLES .

Related Programming Command

none

ATTEN AUTO MAN

Softkey that sets the input attenuation in 10 dB increments. The instrument input attenuator, which is normally coupled (linked) to the reference level control, reduces the power level of the input signal at the input mixer. The attenuator is recoupled when AUTO is underlined.

Key Path

| | |
|-------------|----------|
| | ATTEN |
| (AMPLITUDE) | AUTO MAN |

(AUTO COUPLE) ATTEN
AUTO MAN

CAUTION

- To prevent damage to the input mixer, the power level at the input mixer must not exceed +30 dBm. To prevent signal compression, power at the input to the input mixer must be kept below -10 dBm.
- To protect the mixer from possible damage, 0 dB RF attenuation (no input power reduction to the mixer) can be selected only from the data keys.

Related Programming Command

AT

AUTO
ALL

Softkey that couples the following functions:

- intermeditate frequency bandwidth
- average video bandwidth
- attenuation
- sweep time
- center-frequency step
- average video bandwidth
- average-video-bandwidth to intermediate-frequency-bandwidth ratio.

Key Path

(AUTO COUPLE) AUTO
ALL

Related Programming Command

AUTO

AUTO CAL
ON OFF

Softkey that turns the automatic calibration feature of the EMI receiver on or off.

Key Path

(CALIBRATE) Cal At AUTO CAL
Time ON OFF

Related Programming Command

AUTO CAL

AUTO COUPLE

Hardkey that accesses the softkey menu of functions that can be coupled. (Coupled functions are functions that are linked: if one function is changed, the other function is changed.) The functions that can be auto-coupled are listed below:

- Intermediate frequency bandwidth couples to span.
- Average video bandwidth couples to intermediate frequency bandwidth when the instrument has a average-video-bandwidth to intermediate-frequency-bandwidth ratio of 0.3.
- Sweep time couples to span, intermediate frequency bandwidth, and average video bandwidth.
- RF attenuation couples to reference level.
- Center frequency step size couples to 10% of span.

During normal operation, the sweep time, intermediate frequency bandwidth, and average video bandwidth are coupled to yield optimum performance. If any of these functions becomes uncoupled (that is, is manually set), a “#” will appear next to the screen annotation representing the function on the screen.

If one or more function(s) is manually set so that the amplitude or frequency becomes uncalibrated, MEAS UNCAL appears on the top right-side of the graticule.

Recouple a single function by pressing the function label (to activate the function), and pressing the function again so that AUTO is underlined.

Pressing **AUTO COUPLE**, **AUTO ALL** couples all coupled functions listed.

Related Programming Command

none

AUTO- MEASURE

Softkey that finds all signals on the display and makes an EMI measurement using specified detectors. Each signal is tuned to in sequence, the span is reduced in steps to zero span, and a maximum of three detectors are measured. The detectors used are selected using **DETECTOR PK QP AV**. Measurement time is determined by selecting **AV DWELL TIME**, **PK DWELL TIME**, or **QP DWELL TIME**. After each signal is measured it is added to the signal list. If a limit margin is on, only signals above the margin are measured and added to the list.

Key Path

(TEST) [More](#) [More](#) [AUTO-](#)
1 of 3 2 of 3 MEASURE

Related Programming Command

MEASALLSIGS

(AUTO RANGE)

Hardkey that turns the current state of the auto-range function on or off. When on, the auto-range function automatically adjusts RF attenuation or reference level (IF step-gain) in response to either an IF or RF overload condition detected during the previous sweep.

Auto range requires overload detection capability. The RF filter section must be present (and not in a bypass state) for RF overload detection. IF overload detection does not require the RF filter section.

When on, auto range automatically enables overload detection. When disabled, auto range does *not* disable over load detection.

Related Programming Command

ARNG

AUTOEXEC
ON OFF

Softkey that enables and disables the automatic loading and execution of the file named "AUTOEXEC.DLP" from a DOS disk ("dAUTOEXEC" from a LIF disk). When enabled, the instrument, upon a power-up sequence, will search the disk for an "AUTOEXEC" file and if found will load and execute it.

Key Path

(SETUP) [More](#) [More](#) [AUTOEXEC](#)
1 of 3 2 of 3 ON OFF

Related Programming Command

none

AUTORANG
ON OFF

Softkey that turns the current state of the auto-range function on or off. When on, the auto-range function automatically adjusts RF attenuation or reference level (IF step-gain) in response to either an IF or RF overload condition detected during the previous sweep.

Auto range requires overload detection capability. The RF filter section must be present (and not in a bypass state) for RF overload detection. IF overload detection does not require the RF filter section.

When on, auto range automatically enables overload detection. When disabled, auto range does *not* disable over load detection.

Key Path

SETUP More 1 of 3 Inst Setup AUTORANG ON OFF

Related Programming Command

none

Aux Conn Control

Available only for a standalone receiver RF section.

Softkey that accesses the menu used to control the auxiliary outputs and input. The auxiliary outputs are controlled by pressing **CNTL A 0 1**, **CNTL B 0 1**, **CNTL C 0 1**, and **CNTL D 0 1**. The status of the auxiliary input (control line I), can be displayed on the screen with **DISPLAY CNTL I**.

Key Path

AUX CTRL Aux Conn Control

Related Programming Command

none

AUX CTRL

Hardkey that accesses the softkey menu used for control of the auxiliary interface connector.

Related Programming Command

none

AV DWELL TIME

Softkey that sets the measurement time when the average detector is measured. This key is used in conjunction with **MEASURE AT MKR**, **RE-measure**, **AUTO-MEASURE**, and **MEAS STEPPED**.

Key Path

SETUP More 1 of 3 Inst Setup Measure Detector AV DWELL TIME

Related Programming Command

MEASTIMEAVG

AVERAGE

Hardkey that toggles the average detector on and off. When on, the instrument is placed in linear amplitude detection, the average detector is turned on, and the system settings are optimized to accurately measure average amplitude.

Related Programming Command

none

AVG BW
AUTO MAN

Softkey that specifies the averaging bandwidth, which is a post-detection, low-pass filter. The intermediate frequency bandwidth, average video bandwidth, and sweep time are normally coupled to the span. Selecting MAN uncouples the average video bandwidth from intermediate frequency bandwidth (it does nothing to the sweeptime and span coupling). Selecting AUTO recouples average video bandwidth to the intermediate frequency bandwidth.

Frequency values other than the values in the 1, 3, 10 sequence are rounded to the nearest permissible value.

Key Path

AUTO COUPLE **AVG BW**
AUTO MAN

BW **AVG BW**
AUTO MAN

Related Programming Command

AVBW, VB

AV/IF
BW RATIO

Softkey that determines the automatic setting of average video bandwidth by multiplying the parameter by the intermediate frequency bandwidth. Ratio values other than the values in the 1, 3, 10 sequence are rounded to the nearest permissible value.

Key Path

BW **More** **AV/IF**
1 of 2 **BW RATIO**

Related Programming Command

VBR

B -> C

Softkey that moves trace B into trace C, then stops updating trace C by placing it in the view mode. Trace B is unchanged by BTC. Trace B must contain a complete sweep of measurement information.

Key Path

TRACE More More
1 of 3 2 of 3 B -> C

Related Programming Command

BTC

B <--> C

Softkey that exchanges the contents of trace B with trace C and puts trace B in view mode.

Key Path

TRACE More More
1 of 3 2 of 3 B <--> C

Related Programming Command

BXC

B-DL -> B

Softkey that subtracts the display line from trace B and places the result in trace B. The B-DL -> B function is a math operation. See the **A-B -> A ON OFF** softkey description for information about math operations.

Key Path

TRACE More More
1 of 3 2 of 3 B-DL -> B

Related Programming Command

BML

BACKGRND

Softkey that activates the background of the display screen for color editing.

Key Path

DISPLAY Display Adjust Edit
Config Color Colors BACKGRND

Related Programming Command

SETC

Band Lock

For an HP 8546A/HP 85462A only.

Softkey that accesses the harmonic band menu and the band lock function. Selecting a harmonic band causes the instrument to lock onto the specified harmonic band and automatically select the settings shown in Table 4-1.

Table 4-1.
Center Frequency and Span Settings for Harmonic Bands

| Softkey | Center Frequency | Span | Description |
|-----------------|------------------|-----------|---|
| 0-2.9 Gz BAND 0 | 1.45 GHz | 2.865 GHz | Low-pass filtered, first harmonic mixing. |
| 2.75-6.5 BAND 1 | 4.638 GHz | 3.6 GHz | Preselected, first harmonic mixing. |

BND LOCK ON OFF locks the instrument onto a selected frequency band (local oscillator harmonic number). When only one frequency band is being swept the corresponding softkey will be underlined, even if band lock is off.

Note

For this softkey function to work properly, the corresponding **(INPUT)** must first be selected.

Key Path

(FREQUENCY) More Band
1 of 2 Lock

Related Programming Command

HNLOCK

BAUD RATE

Softkey that specifies the baud rate of an instrument with the RS-232 interface installed.

Note

The RS-232 interface is only available with Option 023.

Key Path

(CONFIG) More BAUD
1 of 3 RATE

Related Programming Command

BAUDRATE

**BLACK
FILL**

Softkey that replaces the standard display screen with a black box. This is one of 18 test patterns that can be used for display-troubleshooting and screen-alignment procedures.

Key Path

| | | | | | |
|-----------|---------|----------|--------|--------|-------|
| | Display | Test | More | More | BLACK |
| (DISPLAY) | Config | Patterns | 1 of 4 | 2 of 4 | FILL |

Related Programming Command

none

**BLACK
LEVEL**

Softkey that replaces the standard display screen with four color bars overlaid on a black background. This is one of 18 test patterns that can be used for display-troubleshooting and screen-alignment procedures.

Key Path

| | | | | |
|-----------|---------|----------|--------|-------|
| | Display | Test | More | BLACK |
| (DISPLAY) | Config | Patterns | 1 of 4 | LEVEL |

Related Programming Command

none

BLANK A

Softkey that stores the amplitude data for trace A and removes it from the screen. The trace A register will not be updated as the instrument sweeps.

Key Path

| | |
|---------|---------|
| (TRACE) | BLANK A |
|---------|---------|

Related Programming Command

BLANK

BLANK B

Softkey that stores the amplitude data for trace B and removes it from the screen. The trace B register will not be updated as the instrument sweeps.

Key Path

(TRACE) BLANK B

Related Programming Command

BLANK

BLANK C

Softkey that stores the amplitude data for trace C and removes it from the screen. The trace C register will not be updated as the instrument sweeps.

Key Path

(TRACE) BLANK C

Related Programming Command

BLANK

BLUE

Softkey that changes the intensity of the blue portion of the primary light source output for the display annotation, traces, graticule, and so on.

Key Path

(DISPLAY) Display Adjust Edit HSL
Config Color Colors ... RGB BLUE

Related Programming Command

none

BLUE FILL

Softkey that replaces the standard display screen with a blue box. This is one of 18 test patterns that can be used for display-troubleshooting and screen-alignment procedures.

Key Path

(DISPLAY) Display Test More More More BLUE
Config Patterns 1 of 4 2 of 4 3 of 4 FILL

Related Programming Command

none

BND LOCK
ON OFF

For an HP 8546A/HP 85462A only.

Softkey that when ON is underlined, the instrument is locked to the lowest frequency band (local oscillator harmonic number) containing the correct center frequency. Start and stop frequencies will be changed if necessary. Executing a band lock limits the tuning range to the selected harmonic number. Selecting the softkeys for either band 0 or band 1 turns on the band lock function automatically.

If the start frequency is well within a lower band, turning band lock off will result in a multiband sweep. If a specific band had been selected prior to changing to a multiband sweep, the softkey label of the selected band will no longer be underlined indicating that it is not selected. Sweep of a single band is indicated if the softkey label of the selected band is underlined.

Note

Before changing the frequency range to another harmonic band, unlock the band by pressing **BND LOCK ON OFF** so that OFF is underlined.

Key Path

| | | | |
|------------------|--------|------|----------|
| | More | Band | BND LOCK |
| FREQUENCY | 1 of 2 | Lock | ON OFF |

Related Programming Command

HNLOCK, HNUNLK

BRIGHT

Softkey that changes the brightness or luminance of the display. The brightness level is shown on the top left-hand side of the screen. Use the knob or step keys to adjust the brightness level.

Key Path

| | | |
|----------------|---------|--------|
| | Display | |
| DISPLAY | Config | BRIGHT |

Related Programming Command

none

BW

Hardkey that activates the intermediate frequency bandwidth function and accesses the softkeys that control the bandwidth functions: 120 kHz EMI BW , 9 kHz EMI BW , 200 Hz EMI BW , IF BW AUTO MAN , AVG BW AUTO MAN , AV/IF BW RATIO , and VID AVG ON OFF . (Also see the IF BW AUTO MAN softkey description.)

Related Programming Command

none

**CABLE
-> DISK**

Softkey that saves cable amplitude-correction data to a floppy disk. To save cable data press, CABLE -> DISK . REGISTER # and PREFIX= are displayed on the screen. Use the data keys to enter the desired register number then press **ENTER** . The message Saving to :FILENAME is displayed. The cable data has now been saved to a disk.

Key Path

| | | | |
|-------------|------|--------|---------|
| | Save | More | CABLE |
| SAVE | Disk | 1 of 2 | -> DISK |

Related Programming Command

none

**Cable
Factors**

Softkey that accesses a menu to turn on, recall, edit, or save cable amplitude-correction factors. Cable factors are conversion factors used to correct for cable insertion loss.

Key Path

| | | | |
|--------------|--------|----------|---------|
| | More | Correctn | Cable |
| SETUP | 1 of 3 | Factors | Factors |

Related Programming Command

AMPCOR

CABLE
ON OFF

Softkey that turns on or off cable amplitude correction factors.

Key Path

(SETUP) More Correctn Cable CABLE
1 of 3 Factors Factors ON OFF

Related Programming Command

AMPCOR

CAL
85422

Softkey that performs a calibration only on the HP 85422E receiver RF section when configured as an HP 8542E EMI receiver.

Key Path

(CALIBRATE) More CAL
1 of 3 85422

Related Programming Command

CAL

CAL
85462

Softkey that performs a calibration only on the HP 85462A receiver RF section when configured as an HP 8546A EMI receiver.

Key Path

(CALIBRATE) More CAL
1 of 3 85462

Related Programming Command

CAL

CAL
ALL

Softkey that initiates frequency and amplitude correction routines.

Key Path

(CALIBRATE) CAL ALL

Related Programming Command

CAL

CAL
AMP

Available only for a standalone receiver RF section.
Softkey that initiates the amplitude correction routine.

Key Path

(CALIBRATE) More 1 of 3 CAL
AMP

Related Programming Command

CAL

Cal
At Time

Softkey that accesses a menu to set the time of an automatic calibration.

Key Path

(CALIBRATE) Cal
At Time

Related Programming Command

CAL

(CAL CHECK)

Hardkey that checks the calibration of the 300 MHz input.

Related Programming Command

CALCHECK

CAL
FETCH

Softkey that retrieves stored self-calibration correction factors from the last calibration saved using CAL STORE.

Key Path

(CALIBRATE) CAL
FETCH

Related Programming Command

CAL

CAL
FREQ

Available only for a standalone receiver RF section.
Softkey that initiates the frequency correction routine.

Key Path

CALIBRATE More CAL
1 of 3 FREQ

Related Programming Command

CAL

CALIBRATE

Hardkey that accesses menus used for the self-calibration, service-diagnostics, and service-calibration functions.

Related Programming Command

none

CAL
INPUT 1

Softkey that calibrates the conducted measurement band of the instrument, 9 kHz to 50 MHz, for amplitude flatness through each filter.

Key Path

CALIBRATE More CAL
1 of 3 INPUT 1

Related Programming Command

CAL

CAL
INPUT 2

Softkey that calibrates the radiated measurement band of the instrument, 20 MHz to 2.9 GHz, for amplitude flatness through each filter.

Key Path

CALIBRATE More CAL
1 of 3 INPUT 2

Related Programming Command

CAL

CAL MXR

For an HP 8546A/HP 85462A only.

Softkey that adjusts the bias-current DAC setting for the optimum displayed-signal amplitude using the 300 MHz CAL OUT signal. This is a service calibration function and is for service use only.

Key Path

(CALIBRATE) More 1 of 3 More 2 of 3 Service Cal CAL MXR

Related Programming Command

none

CAL STORE

Softkey that stores the correction factors from the last calibration. The stored correction factors are automatically retrieved when the instrument is turned on. If correction factors are not stored, they will be retained only until the instrument is turned off. See the description for the CAL FETCH softkey.

Key Path

(CALIBRATE) CAL STORE

Related Programming Command

CAL

CAL TIMEBASE

Softkey that changes the setting of the 10 MHz reference (standard timebase) DAC that is located on the A25 counter lock assembly. This is a service calibration function and is for service use only.

Key Path

(CALIBRATE) More 1 of 3 More 2 of 3 Service Cal CAL TIMEBASE

Related Programming Command

none

CAL
TRK GEN

Softkey that performs absolute amplitude, and vernier self-calibration routines. The instrument should be amplitude calibrated by pressing CAL AMP prior to using the CAL TRK GEN function. Connect the tracking generator output to the instrument input before pressing CAL TRK GEN.

Key Path

| | | | |
|-------------|--------|--------|---------|
| | More | More | CAL |
| (CALIBRATE) | 1 of 3 | 2 of 3 | TRK GEN |

Related Programming Command

CAL

CAL
YTF

For an HP 8546A/HP 85462A only.

Softkey that generates the best slope and offset adjustment to calibrate the YIG-tuned filter (YTF) for each harmonic band. The self-calibration routine, CAL ALL should be performed before running the CAL YTF routine.

Key Path

| | | | |
|-------------|--------|--------|-----|
| | More | More | CAL |
| (CALIBRATE) | 1 of 3 | 2 of 3 | YTF |

Related Programming Command

CAL

CATALOG
ALL

Softkey that catalogs all the programs and variables stored in instrument memory. Press CATALOG REGISTER to catalog states, traces, and limit-line tables, saved in instrument memory.

Key Path

| | | | |
|----------|----------|----------|---------|
| | Recall | Catalog | CATALOG |
| (RECALL) | Internal | Internal | ALL |
| | Save | Catalog | CATALOG |
| (SAVE) | Internal | Internal | ALL |

Related Programming Command

none

CATALOG DISK

Softkey that catalogs the floppy disk. Existing data on the floppy disk will be displayed if the disk has been formatted. If the disk has not been formatted the following message will be displayed:

Cannot read disk drive. Please verify drive door is closed and that disk is formatted and error free.

When cataloging a floppy disk, you can specify the type of information to be cataloged, in either LIF or DOS format.

Key Path

| | | |
|----------|--------|---------|
| | Disk | CATALOG |
| (CONFIG) | Config | DISK |
| | Recall | CATALOG |
| (RECALL) | Disk | DISK |
| | Save | CATALOG |
| (SAVE) | Disk | DISK |

Related Programming Command

CAT

Catalog Internal

Softkey that accesses a menu of cataloging functions for instrument memory: CATALOG ALL, CATALOG REGISTER, CATALOG VARIABLES, and CATALOG PREFIX. Each catalog function displays catalog information. The catalog contains information about the data stored in internal memory. See Figure 4-1 and Table 4-2.

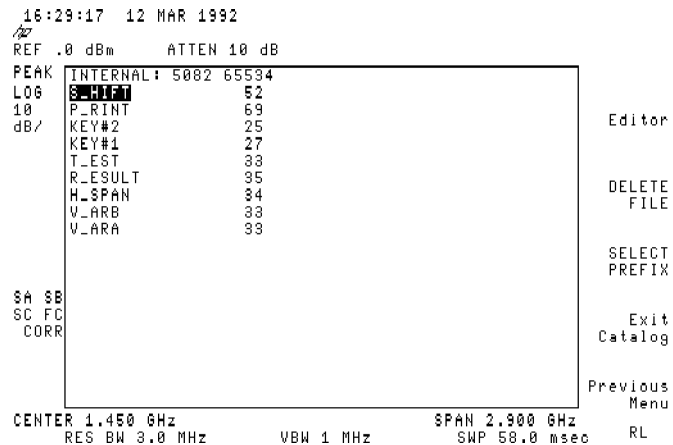

Figure 4-1. Internal Memory Catalog Information

Table 4-2. Internal Memory Catalog Information*

| Callout Number | Description of Items in Figure 4-1 |
|----------------|---|
| 1 | Name of the catalog source. |
| 2 | Bytes of internal memory used. |
| 3 | Total bytes of internal memory available. |
| 4 | Bytes used by item. |
| 5 | Name of item. |

* This table is not applicable when using `CATALOG REGISTER`.

Unlike saving to the floppy disk, data is saved as an item in internal memory.

Use the step keys or knob to view different sections of the directory, then press `LOAD FILE` to select a file. The selected file is highlighted in inverse video.

Each of the catalog softkey functions access the menu that has the `DELETE FILE` function. Use `DELETE FILE` to delete the item from internal memory.

Pressing `CATALOG REGISTER` allows access to the `LOAD FILE` function. Use `LOAD FILE` to load a state or trace from internal memory. Do not use `LOAD FILE` to load limit-line table and amplitude-correction factor items.

Also see the `CATALOG ALL` and `CATALOG VARIABLES` softkey descriptions.

Key Path

`RECALL` `Recall` `Catalog`
`Internal` `Internal`

`SAVE` `Save` `Catalog`
`Internal` `Internal`

Related Programming Command

CAT

CATALOG PREFIX

Softkey that catalogs all of the saved data, that has the specified prefix, that is either on the floppy disk or in internal memory. The entire prefix does not have to be specified. For example, if you want to catalog all the files beginning with the prefix S, specify S as the prefix, using the change prefix function, then select **CATALOG PREFIX**. Prefixed items can be saved in internal memory by either loading in from a floppy disk or using remote programming commands to define them.

Key Path

| | | | |
|-----------------|----------|----------|---------|
| | Recall | Catalog | CATALOG |
| (RECALL) | Internal | Internal | PREFIX |

| | | | |
|---------------|----------|----------|---------|
| | Save | Catalog | CATALOG |
| (SAVE) | Internal | Internal | PREFIX |

Related Programming Command

none

CATALOG REGISTER

Softkey that displays the status of state and trace registers in internal memory. States 1 through 8 are displayed with the center frequency (denoted by CF) and span (denoted by SP). The status of trace registers 0 to the maximum number of traces is displayed also. If a trace, limit-line table, or amplitude correction factors have been saved in the trace register, the screen title (denoted by "TR:") is displayed, otherwise UNUSED is displayed. If the screen title length allows, or if no title is saved with the trace, the time and date are displayed. To load the contents of the state or trace register into internal memory, use the knob or step keys to select the register and press **LOAD FILE**. The **DELETE FILE** key can be used to delete a state or trace register from internal memory.

Note

Do not use **LOAD FILE** to load the contents of a trace register containing limit-line tables or amplitude-correction factors.

Key Path

| | | | |
|-----------------|----------|----------|----------|
| | Recall | Catalog | CATALOG |
| (RECALL) | Internal | Internal | REGISTER |

| | | | |
|---------------|----------|----------|----------|
| | Save | Catalog | CATALOG |
| (SAVE) | Internal | Internal | REGISTER |

Related Programming Commands

none

**CATALOG
VARIABLES**

Softkey that catalogs all of the variables saved in internal memory. Variables can be saved in internal memory by loading in a downloadable program from the floppy disk or defining a function using remote programming commands (VARDEF or TRDEF).

Note

Variables beginning with an underscore are used by the instrument firmware. Modifying these is not recommended and may give unexpected results.

Key Path

Recall Catalog CATALOG
(RECALL) Internal Internal VARIABLES

Save Catalog CATALOG
(SAVE) Internal Internal VARIABLES

Related Programming Command

none

**CENTER
FREQ**

Softkey that activates the center-frequency function to allow the selection of frequency that will be at the center of the screen.

Key Path

CENTER
(FREQUENCY) FREQ

Related Programming Command

CF

**CF STEP
AUTO MAN**

Softkey that changes the step size for the center frequency function. Once a step size has been selected and the center frequency function is activated, the step keys change center frequency by the step-size value. The step size function is useful for finding harmonics and sidebands beyond the current frequency span of the instrument. When auto-coupled, the center frequency step size is set to one graticule (10 percent of the span).

Key Path

CF STEP
(AUTO COUPLE) AUTO MAN

CF STEP
(FREQUENCY) AUTO MAN

Related Programming Command

SS

Change Prefix

Softkey that allows you to enter a prefix that can be used for saving and recalling data to and from the floppy disk, and for cataloging by the prefix. The prefix can be from one to seven characters long. The longer the prefix, the shorter the register number must be. The total length of the prefix and register number cannot exceed eight characters. The prefix can be any character; however, the underscore should not be the first character of the prefix. Pressing **Change Prefix** accesses a menu containing the letters of the alphabet, the underscore symbol (_), the number symbol (#), a space, and the clear function. To select a character, press the softkey that displays the group of characters that contains the desired character. The softkey menu changes to allow you to select an individual character. If you make a mistake, press **(BK SP)** to space back over the incorrect character. Additional characters are available by pressing **More 1 of 2**. Numbers may be selected with the data keys.

A prefix can be cleared with the clear function. Press **(CONFIG)** or **(DISPLAY)**, **Change Prefix**, **YZ_# Spc Clear**, **Clear** to clear the current prefix. The current prefix is blanked by pressing **DEFAULT CONFIG**.

Key Path

| | | |
|-----------------|-----------------------|-------------------------|
| (CONFIG) | More 1 of 3 | Change Prefix |
|-----------------|-----------------------|-------------------------|

| | | |
|------------------|-----------------------|-------------------------|
| (DISPLAY) | More 1 of 2 | Change Prefix |
|------------------|-----------------------|-------------------------|

| | | | |
|-----------------|---------------------------|----------------------------|-------------------------|
| (RECALL) | Recall Internal | Catalog Internal | Change Prefix |
|-----------------|---------------------------|----------------------------|-------------------------|

| | |
|---------------|-------------------------|
| (SAVE) | Change Prefix |
|---------------|-------------------------|

| | | | |
|---------------|-------------------------|----------------------------|-------------------------|
| (SAVE) | Save Internal | Catalog Internal | Change Prefix |
|---------------|-------------------------|----------------------------|-------------------------|

Related Programming Command

PREFIX

Change Title

Softkey that allows you to write a 53-character screen title across the top of the screen. The marker readout may interfere with the last 26 characters. The markers can be turned off by pressing **(MKR)**, **More 1 of 2**, and **MARKER ALL OFF**. Pressing **Change Title** accesses the softkey menus that contain the available characters and symbols. A programming command can be entered in the screen title area. It can then be executed from the front panel by pressing **EXECUTE TITLE**.

The screen title will remain on the screen until either **Change Title** is pressed again or a trace is recalled that was saved with a screen title. A screen title can also be cleared by using the clear function. Press **(DISPLAY)**, **Change Title**, **YZ_# Spc Clear**, **Clear** to clear the current screen title.

Pressing **Change Title** accesses a menu containing the letters of the alphabet, the underscore symbol (**_**), the number symbol (**#**), a space, and the **Clear** softkey. To select a character, press the softkey that displays the group of characters that contains the desired character. The softkey menu changes to allow you to select an individual character. If you make a mistake, press **(BK SP)** to space back over the incorrect character. Additional characters are available by pressing **More 1 of 2**. Numbers may be selected by using the data keys.

Key Path

Receiver Mode

| | | | |
|------------------|---------------|---------------|---------------|
| | Change | | |
| (DISPLAY) | Title | | |
| | More | More | Change |
| (SETUP) | 1 of 3 | 2 of 3 | Title |

Signal Analysis Mode

| | | | |
|------------------|---------------|--------------|---------------|
| | More | Limit | Change |
| (DISPLAY) | 1 of 2 | Lines | Title |
| | More | Limit | Change |
| (SETUP) | 1 of 3 | Lines | Title |

Related Programming Command

TITLE

**CLEAR
ANNOTATN**

Softkey that clears the annotation editor of all text.

Key Path

(OUTPUT) EDIT CLEAR
ANNOTATN ANNOTATN

Related Programming Command

none

**CLEAR
MARK**

Softkey that clears the mark from a signal on the signal list.

Key Path

(TEST) More EDIT Signal CLEAR
1 of 3 LIST Marking MARK

Related Programming Command

SIGUNMARK

**CLEAR
WRITE A**

Softkey that erases any data previously stored in trace A and continuously displays any signals during the sweep of the instrument. This function is activated at power on and by pressing (PRESET).

Changing the trace mode of trace C to clear write or minimum hold can change the trace mode of trace A. If trace A is in clear-write mode or maximum-hold mode when trace C is changed to clear write or minimum hold, the trace mode of trace A is changed to store blank. The following table shows the trace mode of trace A before and after changing trace C to clear-write or minimum-hold trace mode.

| Trace Mode of Trace A Before | Trace Mode of Trace A After |
|------------------------------|-----------------------------|
| Clear write | Store blank |
| Maximum hold | Store blank |
| View | View |

Changing the trace mode of trace A to clear write or maximum hold can change the trace mode of trace C. If trace C is in clear-write mode when trace A is changed to clear write or minimum hold, the trace mode of trace C is changed to minimum hold.

| Trace Mode of Trace C Before | Trace Mode of Trace C After |
|------------------------------|-----------------------------|
| Clear write | Minimum hold |
| Minimum hold | Minimum hold |
| View | View |

Key Path

CLEAR
(TRACE) WRITE A

Related Programming Command

CLRW

CLEAR
WRITE B

Softkey that erases any data previously stored in trace B and continuously displays any signals detected during the sweep of the instrument. This function is activated at power on and by pressing (PRESET).

Changing the trace mode of trace C to clear write or minimum hold can change the trace mode of trace B. If trace B is in clear-write mode or maximum-hold mode when trace C is changed to clear write or minimum hold, the trace mode of trace B is changed to store blank.

The following table shows the trace mode of trace B before and after changing trace C to clear-write or minimum-hold trace mode.

| Trace Mode of Trace B Before | Trace Mode of Trace B After |
|------------------------------|-----------------------------|
| Clear write | Store blank |
| Maximum hold | Store blank |
| View | View |

Changing the trace mode of trace B to clear write or maximum hold can change the trace mode of trace C. If trace C is in clear-write mode when trace B is changed to clear write or minimum hold, the trace mode of trace C is changed to minimum hold.

| Trace Mode of Trace C Before | Trace Mode of Trace C After |
|------------------------------|-----------------------------|
| Clear write | Minimum hold |
| Minimum hold | Minimum hold |
| View | View |

Key Path

CLEAR
(TRACE) WRITE B

Related Programming Command

CLRW

**CLEAR
WRITE C**

Softkey that erases any data previously stored in trace C and continuously displays any signals detected during the sweep of the instrument. This function is activated at power on and by pressing **(PRESET)**.

Changing the trace mode of trace C to clear write or minimum hold can change the trace mode of trace A and trace B. If trace A or trace B is in clear-write mode or maximum-hold mode when trace C is changed to clear write or minimum hold, the trace mode of trace A or trace B is changed to store blank. The following table shows the trace mode of trace A or trace B before and after changing trace C to clear-write or minimum-hold trace mode.

| Trace Mode of Trace A or B Before | Trace Mode of Trace A or B After |
|-----------------------------------|----------------------------------|
| Clear write | Store blank |
| Maximum hold | Store blank |
| View | View |

If you want to use trace A or trace B in the clear-write or maximum-hold mode and do not want trace C to blank it, use minimum-hold or view-trace mode for trace C.

Key Path

(TRACE) **CLEAR
WRITE C**

Related Programming Command

CLRW

**CLR ALL
MARKS**

Softkey that clears all signals in the signal list.

Key Path

(TEST) **More
1 of 3** **EDIT
LIST** **Signal
Marking** **CLR ALL
MARKS**

Related Programming Command

SIGUNMARK

CNTL A
0 1

Available only for a standalone receiver RF section.

Softkey that makes the auxiliary-interface control line A output high or low (TTL). This line can be used to control any external drive that takes a TTL input.

Key Path

| | | |
|----------|----------|--------|
| | Aux Conn | CNTL A |
| AUX CTRL | Control | 0 1 |

Related Programming Command

CNTLA

CNTL B
0 1

Available only for a standalone receiver RF section..

Softkey that makes the auxiliary-interface control line B output high or low (TTL). This line can be used to control any external drive that takes a TTL input.

Key Path

| | | |
|----------|----------|--------|
| | Aux Conn | CNTL B |
| AUX CTRL | Control | 0 1 |

Related Programming Command

CNTLB

CNTL C
0 1

Available only for a standalone receiver RF section.

Softkey that makes the auxiliary-interface control line C output high or low (TTL). This line can be used to control any external drive that takes a TTL input.

Key Path

| | | |
|----------|----------|--------|
| | Aux Conn | CNTL C |
| AUX CTRL | Control | 0 1 |

Related Programming Command

CNTLC

CNTL D
0 1

Available only for a standalone receiver RF section.

Softkey that makes the auxiliary-interface control line D output high or low (TTL). This line can be used to control any external drive that takes a TTL input.

Key Path

(AUX CTRL) Aux Conn CNTL D
Control 0 1

Related Programming Command

CNTLD

COARSE
TUNE DAC

Softkey that displays the analog output of the YTO coarse-tune DAC located on the A7 analog interface assembly. This is a service diagnostic function and is for service use only.

Key Path

(CALIBRATE) More More Service
1 of 3 2 of 3 Diag More 1 More 2
COARSE
TUNE DAC

Related Programming Command

none

COLOR
BARS

Softkey that replaces the standard display screen with a color bars. This is one of 18 test patterns that can be used for display-troubleshooting and screen-alignment procedures.

Key Path

(DISPLAY) Display Test More COLOR
Config Patterns 1 of 4 BARS

Related Programming Command

none

COLOR
MONOCHRM

Softkey that specifies either a color print when COLOR is underlined or a black and white print when MONOCHRM is underlined. This function is used when a color printer is connected to the output port.

Key Path

CONFIG Print Config Print Options COLOR MONOCHRM

Related Programming Command

none

COMPLMNT
MARKS

Softkey that complements all marked signals in the signal list. For example, if all the even numbered signals in the signal list are marked, pressing **COMPLMNT MARKS**, with mark all odd numbered signals instead.

Key Path

TEST More 1 of 3 EDIT LIST Signal Marking Selectv Mark COMPLMNT MARKS

Related Programming Command

SIGMARK

CONFIG

Hardkey that accesses the menu used for printer and plotter configurations, time and date display functions, changing the current prefix, floppy disk configuration functions, disposing of user-defined variables and programs from internal memory, changing the instrument address or the baud rate, displaying the installed options on screen, and changing the format of the MONITOR output. Pressing **CONFIG** after the instrument has been placed in the remote mode places the instrument in the local mode and enables front-panel control. During remote operation, an R appears in the lower-right corner of the screen indicating remote mode. Pressing **CONFIG** removes the R annotation from the lower-right corner.

Related Programming Command

none

CONFIG
DONE

Softkey that sets the specified printer type then exits the menu.

Key Path

Print Printer Config
CONFIG Config Type Done

Related Programming Command

none

COPY

Hardkey that initiates an output of the screen data, without an external controller, to a previously specified graphics printer or plotter. Refer to the programmer's guide for detailed information about printing and plotting.

The printer or plotter must have already been selected using CONFIG and either Plot Config (for a plotter) or Print Config (for a printer). To obtain a print, press CONFIG, COPY DEV PRNT PLT (so that PRNT is underlined), then Print Config.

If the instrument is connected to an HP PaintJet printer and you want a color printout, press Printer Type, More 1 of 3, PAINTJET PRINTER. If the instrument is connected to an HP PaintJet printer and you want a black and white printout, press Print Options then, COLOR MONOCHRM so that MONOCHRM is underlined. The paintjet printer's mode switches must be set correctly for use with the instrument. The switch settings are indicated in Table 4-3. If the switch settings are changed, the printer must be turned off and then back on after they are changed. More Thinkjet printer information can be found in the programmer's guide.

Table 4-3. Setting of Thinkjet Printer Mode Switches

| Switch Number | Setting | Comments |
|---------------|---------|---|
| 1 | down | Printer performs a carriage return only. |
| 2 | down | Printer performs a line feed only. |
| 3 | up | Sets the printer to skip paper perforations |
| 4 | down | Sets the printer for a paper length of 11 inches. |
| 5 | down | Sets the printer to HP MODE. |
| 6 | up | Sets the printer to USASCII. |
| 7 | down | |
| 8 | down | |

If you want the softkey labels to be printed with the instrument display printout when using COPY, press PRT MENU ON OFF so that ON is underlined.

Press **COPY** and the process will begin. The screen remains frozen (no further sweeps taken) until the data transfer to the printer is complete. The instrument works with many Hewlett-Packard printers.

The plotting process is similar to the printing process. On the spectrum analyzer, press **CONFIG**, **Plot Config**. For Option 023, use **BAUD RATE** to change the baud rate of the instrument, if necessary.

With **PLTS/PG 1 2 4**, you can choose a full-page, half-page, or quarter-page plot. Press **PLTS/PG 1 2 4** to underline the number of plots per page desired. If two or four plots per page are chosen, a softkey function is displayed that allows you to select the location of the plotter output on the paper. If two plots per page are selected, **PLT []LOC _ _** is displayed. If four plots per page are selected, **PLT []_LOC _ _** is displayed. Press the softkey until the rectangular marker is in the desired section of the softkey label. The upper and lower sections of the softkey label graphically represent the position of the page where the plotter output will be located.

Note

The HP 7470A plotter does not support two plots per page output, you can select one or four plots per page, but not two plots per page.

For a multipen plotter, the pens of the plotter draw the different components of the screen as follows:

| Pen Number | Description |
|------------|--|
| 1 | Draws trace A, the active function, markers, display line, and softkeys. |
| 2 | Draws limit 2, status and error messages. |
| 3 | Draws limit 1 and the annotation. |
| 4 | Draws the graticule. |
| 5 | Draws trace C. |
| 6 | Draws trace B. |

To plot, press **Previous Menu**, **COPY DEV PRNT PLT** (PLT should be underlined), and **COPY**.

Printing is usually faster than plotting, but plotting provides higher resolution output. The instrument works with plotters such as the HP 7440A.

Figure 4-2 shows the rear view of a typical printer and instrument configuration.

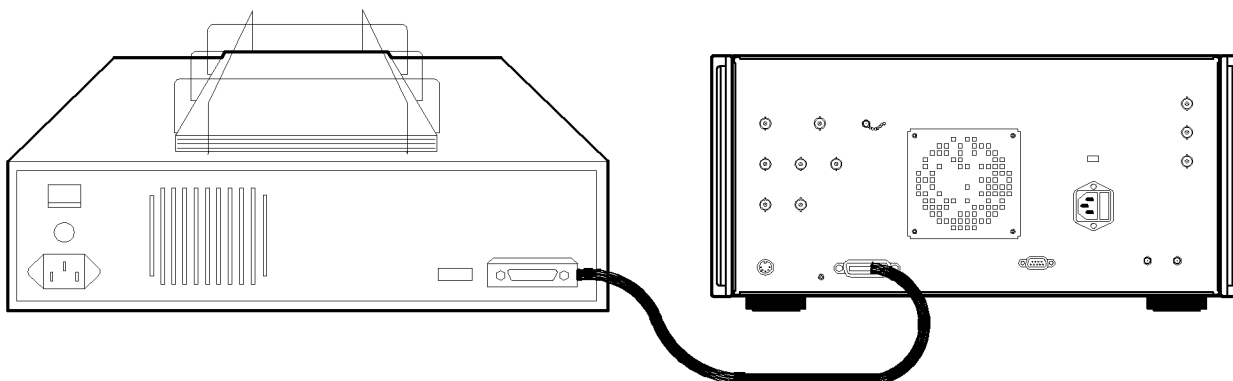

Figure 4-2. Connecting a Printer to the Instrument

Note Printing and plotting require an optional interface. Generally, instruments with an HP-IB interface set the plotter address to 5 and the printer address to 1. Instruments with an RS-232 interface must have the baud rate set to match the baud rate of the printer or plotter being used. The programmer's guide that comes with the optional interfaces details the different interfaces. Refer to the programmer's guide for more information about printing and plotting.

Related Programming Commands

PLOT, PRINT

COPY DEV
PRNT PLT

Softkey that changes between a printer and plotter. For example, if you have been printing and want to do a plot, press COPY DEV PRNT PLT to underline PLT before pressing (COPY).

Key Path

(CONFIG) COPY DEV
PRNT PLT

Related Programming Command

none

COPY
SCREEN

Softkey that sends a copy of the current display to the printer specified by **Printer Type**.

Key Path

OUTPUT COPY
SCREEN

Related Programming Command

none

CORRECT
ON OFF

Softkey that controls use of some correction factors. When ON is underlined, correction factors are used and CORR appears on the left hand-side of the display. When OFF is underlined, correction factors are not used. Turning the correction factors off degrades amplitude accuracy.

Note

Correction factors must be on for the instrument to meet its specified performance.

Key Path

CALIBRATE CORRECT
ON OFF

Related Programming Command

CAL

Correctn
Factors

Softkey that accesses a menu of correction factors used to create, edit, and view antenna, cable, and other amplitude-correction factors.

Key Path

SETUP More Correctn
1 of 3 Factors

Related Programming Command

AMPCOR

CORRECTN
ON OFF

Softkey that turns antenna, cable, or other amplitude-correction factors on or off.

Key Path

More Correctn CORRECTN
(SETUP) 1 of 3 Factors ON OFF

Related Programming Command

CORREK

COUPLE
AC DC

Softkey that specifies alternating-current (AC) or direct-current (DC) coupling at the instrument input. Selecting ac coupling blocks any dc voltage at the instrument input; however, the ac coupling also decreases the frequency range of the instrument. The input coupling is set to ac by an instrument preset.

Amplitude specifications apply only when coupling is set to DC.

CAUTION

Do not use dc coupling if there is any dc voltage at the instrument input.

Key Path

More More COUPLE
(AMPLITUDE) 1 of 3 2 of 3 AC DC

Related Programming Command

COUPLE

CNT RES
AUTO MAN

Softkey that sets the resolution of the marker frequency counter. When AUTO is underlined, the marker counter resolution is set to 6 kHz. When MAN is underlined, the marker counter resolution can be set manually from 1 Hz to 100 kHz.

Key Path

More CNT RES
(MARKER FUNCTION) 1 of 2 AUTO MAN

Related Programming Command

MKFCR

CTRL

Hardkey that activates the windows display mode and accesses the menu of window zone functions. The windows display function splits the screen into two separate displays. Only one of these displays is active at a time. The currently active window will have a highlighted line around the graticule. The WINDOWS **NEXT** key will switch the active display between the upper and lower windows. The instrument state of the active window can be changed without affecting the state of the inactive window. The complete annotation is not displayed for each window because of space limitations.

When the windows display mode is first turned on, the top window will contain an inactive copy of the previous full display. The lower window will be active and will display a subset of the frequency span of the upper window. The displayed span, or zone, of the lower window will be indicated on the upper window by two vertical lines called zone markers. The zone can be moved and changed using the zone keys which are accessed by pressing the WINDOWS **CTRL** key. Changing the span or center frequency of the lower window will change the corresponding zone markers on the upper window.

Most functions can be used from within the windows display mode. Some functions, like editing limit lines and showing the options, require a full-sized display. They will temporarily exit the windows display format. When the function is finished the instrument will return to a windows display. Other functions will permanently exit the windows display and it will be necessary to restart the windows display mode by pressing WINDOWS **CTRL**. See Table 4-4.

Limit lines can be displayed and tested within the windows display mode. Viewing and testing must be turned on independently in each window. The current limit lines will be common to both windows.

SAVE and **RECALL** do not save the windows display mode. If the windows display mode is being used, the save state function saves the state of the currently active window. The recall state function recalls the stored state into the currently active window. See the **STATE -> INTRNL** softkey description for more information about saving the display.

Table 4-4.
Functions Which Exit The Windows Display Format

| Function | Description |
|-----------------------|---|
| Calibration Functions | self-calibration routines |
| Dispose User Memory | deletes user's items from instrument memory |
| Instrument Preset | returns instrument to preset state |

Related Programming Command

WINON

DACS

Available only for a standalone receiver RF section.

Softkey that changes the DAC numbers of the span, DAC YTO coarse-tune, DAC YTO fine-tune, and YTO FM tune DAC located on the A7 analog interface assembly. This is a service diagnostic function and is for service use only.

Key Path

CALIBRATE More 1 of 3 More 2 of 3 Service Diag More 1 ... More 6
DACS

Related Programming Command

none

DATEMODE MDY DMY

Softkey that changes the display of the date from a month-day-year format to a day-month-year format. It is set to a month-day-year format by pressing **DEFAULT CONFIG**.

Key Path

CONFIG More 1 of 3 Time date DATEMODE MDY DMY

Related Programming Command

DATEMODE

dBm

Softkey that changes the amplitude units to dBm for the current setting (logarithmic or linear).

Key Path

AMPLITUDE More 1 of 3 Amptd Units dBm

Related Programming Command

none

dBmV

Softkey that changes the amplitude units to dBmV for the current setting (logarithmic or linear).

Key Path

AMPLITUDE More 1 of 3 Amptd Units dBmV

Related Programming Command

none

dB μ V

Softkey that changes the amplitude units to dB μ V for the current setting (logarithmic or linear).

Key Path

AMPLITUDE More 1 of 3 Amptd Units dB μ V

Related Programming Command

none

**DEFAULT
CAL DATA**

Softkey that accesses the factory-default correction factors. A special pass code is required for use. If the message Self cal needed appears when **DEFAULT CAL DATA** is pressed, the **CAL FREQ** and **CAL AMP** routines need to be run. **CAL ALL** must be run to ensure specifications. (If the maximum frequency of interest is higher than 3 GHz, the **CAL YTF** routine must also be run.) The calibration results must then be saved by pressing **CAL STORE**.

Key Path

CALIBRATE More 1 of 3 More 2 of 3 DEFAULT CAL DATA

Related Programming Command

CAL

DEFAULT COLORS

Softkey that sets all the display screen attributes to the factory-defined colors. To change the color elements, refer to [Edit Colors](#).

Key Path

DISPLAY Display Adjust DEFAULT
Config Color COLORS

Related Programming Command

SETC

DEFAULT CONFIG

Softkey that resets the instrument configuration to the state it was in when it was originally shipped from the factory then performs an instrument preset. See [Table 4-5](#) for the default user-configuration values set by pressing [DEFAULT CONFIG](#).

Table 4-5. Default Configuration Values

| Configuration | Default Value |
|--|-------------------------|
| Analyzer address ¹ | 18 |
| Copy device | printer |
| CRT position (Horizontal and Vertical) | 10, 48 |
| Printer address (Option 023) | 1 |
| Plotter address (Option 023) | 5 |
| Baud rate (Option 023) | 1200 |
| External preamp | 0 dB |
| Save lock (internal states or traces) | Off |
| Printer | black and white printer |
| Print menu | on |
| Plots per page | 1 |
| Time/date display | on |
| Date mode | month-day-year format |
| Prefix | (blank) |
| Analyzer state at power on | instrument preset |

¹ Signal analysis mode only.

Key Path

CONFIG More DEFAULT
1 of 3 CONFIG

Related Programming Command

none

Define List

Softkey that accesses a menu that specifies what elements of a table are output to the printer when `OUTPUT REPORT` is executed. If any of the elements are set to on, they will be included as part of the list portion of the report.

Key Path

`(OUTPUT)` Define List

Related Programming Command

TBLDEF

Define Report

Softkey that accesses a menu which specifies what elements of a report are output to the printer or the plotter. If any of the elements are set to on, they will be sent to the printer followed by a form feed. Only `LOG ON OFF` and `LIN ON OFF` can be used when outputting to a plotter. The report is generated by `OUTPUT REPORT`.

Key Path

`(OUTPUT)` Define Report

Related Programming Command

RPTDEF

DEFINE USER KEY

Softkey that sets the instrument in a mode for redefining a user-defined key. It freezes the display and presents instructions in the active function area. The mode is exited by pressing one of the two user-defined keys.

Key Path

`(SETUP)` More 1 of 3 More 2 of 3 DEFINE USER KEY

Related Programming Command

UDKDEFINE, UDKSET

**DELETE
ALL SIGS**

Softkey that deletes all signals from the signal list.

Key Path

TEST More 1 of 3 EDIT LIST Delete Signals DELETE ALL SIGS

Related Programming Command

SIGDEL

**DELETE
FACTORS**

Softkey that deletes all antenna, cable, or other amplitude-correction factors.

Key Path

SETUP More 1 of 3 Correctn Factors Antenna Factors EDIT ANTENNA More 1 of 2
DELETE FACTORS

SETUP More 1 of 3 Correctn Factors Cable Factors EDIT CABLE More 1 of 2
DELETE FACTORS

SETUP More 1 of 3 Correctn Factors Other Factors EDIT OTHER More 1 of 2
DELETE FACTORS

Related Programming Command

none

**DELETE
FILE**

Softkey that deletes an item from internal memory or a file from the floppy disk. Use the step keys to view different sections of the directory and use the knob to select the file or item to delete. Pressing **DELETE FILE** causes a message to appear on the screen: If you are sure, press key again to purge data. Press **DELETE FILE** again if you want to delete the memory item.

Note

Deleting items beginning with an underscore from the instrument is not recommended and may have unexpected results. Items beginning with an underscore are used by the instrument.

Key Path

| | | | |
|---------------|--------------------|---------------------|----------------------------------|
| RECALL | Recall Disk | ... * | DELETE FILE |
| RECALL | Recall Disk | More 1 of 2 | ... † DELETE FILE |
| RECALL | Recall Internal | Catalog Internal | ... § DELETE FILE |
| SAVE | Save Disk | CATALOG DISK | DELETE FILE |
| SAVE | Save Internal | Catalog Internal | ... § DELETE FILE |
| SETUP | RECALL SETUP | DELETE FILE | |
| SETUP | More 1 of 3 | Correctn Factors | ... DELETE FILE |
| TEST | More 1 of 3 | Save/Rcl List | RECALL LIST DELETE FILE |

Receiver mode only

| | | | | |
|----------------|----------------|----------------|------------------|----------------|
| DISPLAY | More 1 of 2 | Limit Lines | RECALL LIMITS | DELETE FILE |
|----------------|----------------|----------------|------------------|----------------|

* Any of the following can be used to complete the key path:
CATALOG DISK, RECALL SETUP, RECALL LIST,
RECALL LIMITS, or RECALL ANTENNA.

† Any of the following can be used to complete the key path:
RECALL CABLE, RECALL OTHER, or RECALL TRACE.

§ Any of the following can be used to complete the key path:
CATALOG ALL, CATALOG REGISTER, CATALOG VARIABLES,
or CATALOG PREFIX.

|| Any of the following groups of softkeys can be used to complete the key path:
Antenna Factors EDIT ANTENNA, or Cable Factors EDIT CABLE,
or Other Factors EDIT OTHER.

Related Programming Command

PURGE

**DELETE
LIMIT**

Receiver mode only.

Softkey that deletes the selected limit-line table.

Key Path

(DISPLAY) More 1 of 2 Limit Lines ... * DELETE LIMIT

(SETUP) More 1 of 3 Limit Lines ... * DELETE LIMIT

* Either **Limit 1** or **Limit 2** can be used to complete the key path.

Related Programming Command

LIMIDEL

**DELETE
MARKED**

Softkey that deletes all marked signals from the signal list. Signals can be marked using **MARK ALL SIGNALS**, **MARK SIGNAL**, and **Selectv Mark**.

Key Path

(TEST) More 1 of 3 EDIT LIST Delete Signals DELETE MARKED

Related Programming Command

SIGDEL, SIGMARK

**DELETE
POINT**

Softkey that deletes an amplitude-correction factor that was previously selected by **SELECT POINT**.

Key Path

(SETUP) More 1 of 3 Correctn Factors Antenna Factors EDIT ANTENNA More 1 of 2 DELETE POINT

(SETUP) More 1 of 3 Correctn Factors Cable Factors EDIT CABLE More 1 of 2 DELETE POINT

(SETUP) More 1 of 3 Correctn Factors Other Factors EDIT OTHER More 1 of 2 DELETE POINT

Related Programming Command

none

DELETE SEGMENT

Softkey that deletes the limit-line entry for the selected segment number. Use the knob or step keys to highlight the segment number to be deleted, then press **DELETE SEGMENT**.

Key Path

Receiver Mode

| | | | | | | |
|----------------|--------|-------|-------|-------|--------|---------|
| | More | Limit | | EDIT | More | DELETE |
| DISPLAY | 1 of 2 | Lines | ... * | LIMIT | 1 of 2 | SEGMENT |
| | More | Limit | | EDIT | More | DELETE |
| SETUP | 1 of 3 | Lines | ... * | LIMIT | 1 of 2 | SEGMENT |

* Either **Limit 1** or **Limit 2** can be used to complete the key path.

Signal Analysis Mode

| | | | | | | |
|----------------|--------|-------|-------|-------|--------|---------|
| | More | Limit | Edit | | More | DELETE |
| DISPLAY | 1 of 2 | Lines | Limit | ... * | 1 of 2 | SEGMENT |
| | More | Limit | Edit | | More | DELETE |
| SETUP | 1 of 3 | Lines | Limit | ... * | 1 of 2 | SEGMENT |

* Any of the following can be used to complete the key path:
EDIT UPPER, **EDIT LOWER**, **EDIT UP/LOW**, or **EDIT MID/DELT**.

Related Programming Command

SEGDEL

DELETE SIGNAL

Softkey that deletes the signal located at the cursor from the signal list.

Key Path

| | | | | |
|-------------|--------|------|---------|--------|
| | More | EDIT | Delete | DELETE |
| TEST | 1 of 3 | LIST | Signals | SIGNAL |

Related Programming Command

SIGDEL

Delete Signals

Softkey that accesses a menu which deletes one or more signals from the signal list.

Key Path

More EDIT Delete
(TEST) 1 of 3 LIST Signals

Related Programming Command

SIGDEL

DELTA MEAS

Softkey that accesses the (PEAK SEARCH) menu. See (PEAK SEARCH) for more information.

Key Path

More DELTA
(MEAS/USER) 1 of 2 MEAS

Related Programming Command

none

DEMOD AM FM

Softkey that allows selection of amplitude (AM) or frequency (FM) demodulation.

Activating AM detection turns off FM demodulation (if it is on). When the frequency span is greater than 0 Hz, a 30 kHz intermediate frequency bandwidth is used during demodulation, regardless of the screen annotation.

Turning FM demodulation on turns off AM demodulation (if it is on). When the frequency span is greater than 0 Hz, a 100 kHz bandwidth is used during the demodulation, regardless of the screen annotation. When the span is equal to 0 Hz, the displayed bandwidth is used.

Key Path

DEMOD
(SELECT) AM FM

Related Programming Command

none

DEM
ON OFF

Softkey that turns the AM or FM demodulation on and off. If the instrument is in a nonzero span, a marker is placed at center screen if an onscreen marker is not already present. The marker pause is changed to equal the current dwell time value. Demodulation takes place on any signal that is indicated by the marker position during the marker pause. There is no change to the display during marker pause, but the demodulation signal is present on the AUX VIDEO OUT. Also see the `SPEAKER ON OFF` softkey description.

Pressing `DEM ON OFF` selects the sample peak detector for AM demodulation, the FMV detector for FM demodulation. If the instrument is in zero span, demodulation is done continuously, with or without an onscreen marker.

Key Path

DEM
ON OFF

Related Programming Command

DEM
ON OFF

DESKJET

Softkey that specifies DeskJet as the printer connected to the output port.

Key Path

Print Printer More
Config Type 1 of 3 DESKJET

Related Programming Command

PRNTTYPE

DESKJET
500

Softkey that specifies DeskJet 500 as the printer connected to the output port.

Key Path

Print Printer More DESKJET
Config Type 1 of 3 500

Related Programming Command

PRNTTYPE

**DESKJET
500C**

Softkey that specifies DeskJet 500C as the printer connected to the output port.

Key Path

| | | | | |
|-----------------|--------|---------|--------|---------|
| | Print | Printer | More | DESKJET |
| (CONFIG) | Config | Type | 1 of 3 | 500C |

Related Programming Command

PRNTTYPE

**DESKJET
550C**

Softkey that specifies DeskJet 550C as the printer connected to the output port.

Key Path

| | | | | |
|-----------------|--------|---------|--------|---------|
| | Print | Printer | More | DESKJET |
| (CONFIG) | Config | Type | 1 of 3 | 550C |

Related Programming Command

PRNTTYPE

**DETECTOR
PK QP AV**

Softkey that turns automatic measuring on or off for the peak, quasi-peak, and average detectors. Underline the desired detector or detectors by pressing DETECTOR PK QP AV.

Key Path

| | | | | |
|----------------|--------|-------|----------|-----------------|
| | More | Inst | Measure | DETECTOR |
| (SETUP) | 1 of 3 | Setup | Detector | <u>PK QP AV</u> |

| | | | | |
|---------------|--------|------|---------|-----------------|
| | More | EDIT | Re- | DETECTOR |
| (TEST) | 1 of 3 | LIST | measure | <u>PK QP AV</u> |

Related Programming Command

AUTOAVG, AUTOQPD

**DETECTOR
SMP PK**

Softkey that selects either positive peak detection or sample detection. When sample detection is selected, SMPL appears in the upper-right corner of the screen. In sample mode, the instantaneous signal value at the present display point is placed in memory. Sample detection is activated automatically for noise level markers, during video averaging, and for FFT measurements.

When positive peak detection is selected, PEAK appears in the upper-right corner of the screen. Positive peak detection obtains the maximum video signal between the last display point and the present display point and stores this value in the trace memory address. Positive peak detection is selected at power on and by pressing **PRESET**.

Key Path

TRACE **More** **DETECTOR**
1 of 3 **SMP PK**

Related Programming Command

DET

**Disk
Config**

Softkey that accesses a menu to format a 3.5 inch double-sided floppy disk in either LIF or DOS format. **Disk Config** also accesses the Catalog Disk and Protect functions.

Key Path

CONFIG **Disk**
Config

Related Programming Command

none

DISPLAY

Hardkey that activates the display line, hold, and threshold functions. It controls the display of the graticule and screen annotation, and provides for title and prefix entries. **DISPLAY** also accesses display configuration capabilities such as color adjustments and test pattern selections.

Related Programming Command

none

DISPLAY
-> DISK

Softkey that saves display images to a floppy disk. To save display images press, DISPLAY -> DISK . REGISTER # and PREFIX= are displayed on the screen. Use the data keys to enter the desired register number then press (ENTER). The message Saving to :FILENAME is displayed. The display image has now been saved to a disk. For a DOS file system, the file is a standard *.BMP file which can be used in many windows applications.

Key Path

(SAVE) Save More DISPLAY
Disk 1 of 2 -> DISK

Related Programming Command

none

DISPLAY
CAL DATA

Softkey that displays the current correction-factor data generated by the frequency and amplitude self-calibration routines. This is a service diagnostic function and is for service use only.

Key Path

(CALIBRATE) More More Service DISPLAY
1 of 3 2 of 3 Diag CAL DATA

Related Programming Command

none

DISPLAY
CNTL I

Available only for a standalone receiver RF section.

Softkey that displays the status of the auxiliary connector input (control line I) onscreen (high = 1 or low = 0, in TTL).

Key Path

(AUX CTRL) Aux Conn DISPLAY
Control CNTL I

Related Programming Command

CNTLI

Display Config

Softkey that accesses a menu that includes adjust color and test pattern menus along with softkeys to adjust the intensity and brightness of your display.

Key Path

Display
Config
DISPLAY

Related Programming Command

none

Display Sys Data

Softkey that accesses a menu to display system calibration data for input 1. These keys are for service use only.

Key Path

More More Service Display
1 of 3 2 of 3 Diagnostic Sys Data
CALIBRATE

Related Programming Command

none

DISPOSE USER KEY

Softkey that frees internal memory that was previously allocated for the user-defined keys and reverts the keys to their factory definitions.

Key Path

More Dispose DISPOSE
1 of 3 User Mem USER KEY
CONFIG

Related Programming Command

DISPOSE

Dispose User Mem

Softkey that accesses a menu to dispose of all the user programs and variables that are in internal memory.

Note

Use **DELETE FILE** to selectively delete stored programs or variables from internal memory.

Using **DISPOSE USER MEM** may change the printer or plotter configuration. Pressing **DISPOSE USER MEM** sets the printer output to print a black and white print by selecting **COLOR MONOCHRM**, sets the copy device to print when **COPY DEV PRNT PLT** has PRNT

underlined, and sets the print menu to on when **PRT MENU ON OFF** has ON underlined. Use **Print Config** to change any of these functions.

Key Path

CONFIG More 1 of 3 Dispose User Mem

Related Programming Command

DISPOSE

DROOP

Softkey that disables the reset of the peak detector on the A16 processor/video assembly after each analog-to-digital conversion. This is a service diagnostic function and is for service use only.

Key Path

CALIBRATE More 1 of 3 More 2 of 3 Service Diag More 1 ... More 3
DROOP

Related Programming Command

none

DSP LINE ON OFF

Softkey that activates an adjustable horizontal line that is used as a visual reference line. The line, which can be used for trace arithmetic, has amplitude values that correspond to its vertical position when compared to the reference level. The value of the display line appears in the active function block and on the left side of the screen. The display line can be adjusted using the step keys, knob, or data keys. To deactivate the display line, press **DSP LINE ON OFF** so that OFF is underlined. (Also see the **VIDEO** softkey description.)

Key Path

DISPLAY DSP LINE ON OFF

MARKER FUNCTION More 1 of 2 DSP LINE ON OFF

PEAK SEARCH More 1 of 2 DSP LINE ON OFF

Related Programming Command

DL

DWELL
TIME

Softkey that sets the dwell time for marker pause, during which demodulation can take place in nonzero span sweeps. The dwell time can be set from 2 milliseconds to 100 seconds.

Key Path

(SELECT) DWELL
TIME

Related Programming Command

none

EDIT
ANNOTATN

Softkey that accesses the annotation editor. The annotation editor allows entry of up to 1500 characters of text using an external keyboard. The annotation text can be stored to a disk or printed using `OUTPUT REPORT`.

Key Path

(OUTPUT) EDIT
ANNOTATN

Related Programming Command

EDITANNOT

EDIT
ANTENNA

Softkey that accesses a menu used to edit antenna amplitude-correction factors.

Key Path

(SETUP) More Correctn Antenna EDIT
1 of 3 Factors Factors ANTENNA

Related Programming Command

AMPCOR

**EDIT
CABLE**

Softkey that accesses a menu used to edit cable amplitude-correction factors.

Key Path

(**SETUP**) More Correctn Cable EDIT
1 of 3 Factors Factors CABLE

Related Programming Command

AMPCOR

**EDIT
CAT ITEM**

Softkey that starts the DLP editor function and loads the highlighted item from the catalog of instrument memory to be displayed and edited. It copies the item into the instruments internal DLP editor memory which is a 2500 byte memory buffer. If an item is edited, the new edited version will not be overwritten in the internal memory until it is processed by the **SAVE EDIT** softkey.

Key Path

(**RECALL**) Recall Catalog EDIT
Internal Internal ... * Editor CAT ITEM

(**SAVE**) Save Catalog EDIT
Internal Internal ... * Editor CAT ITEM

* Any of the following can be used to complete the key path:

CATALOG ALL , CATALOG VARIABLE , or CAT PREFIX .

Related Programming Command

none

**Edit
Colors**

Softkey that accesses a menu to change the display screen colors.

Key Path

(**DISPLAY**) Display Adjust Edit
Config Color Colors

Related Programming Command

SETC

EDIT DONE

Softkey that can be accessed through the amplitude-correction, menu the limit-line menu, and the change prefix menu. When accessed from the amplitude-correction menu, the amplitude-correction factors table is erased from the screen and the amplitude-correction menu is restored onscreen. When accessed from the limit-line menu, the limit-line table is erased from the screen and the limit-line menu is restored onscreen. Use **EDIT DONE** when all the amplitude-correction factors have been entered.

When accessed from the change prefix menu, **EDIT DONE** erases the prefix from the screen and restores the previous menu. Use **EDIT DONE** when prefix characters have all been entered.

Key Path

| | | | | |
|---------------|--------|--------|--------|------|
| | More | Change | More | EDIT |
| CONFIG | 1 of 3 | Prefix | 1 of 2 | DONE |

| | | | | |
|----------------|--------|--------|--------|------|
| | More | Change | More | EDIT |
| DISPLAY | 1 of 2 | Prefix | 1 of 2 | DONE |

| | | | | | |
|---------------|----------|----------|--------|--------|------|
| | Recall | Catalog | Change | More | EDIT |
| RECALL | Internal | Internal | Prefix | 1 of 2 | DONE |

| | | | | | |
|-------------|----------|----------|--------|--------|------|
| | Save | Catalog | Change | More | EDIT |
| SAVE | Internal | Internal | Prefix | 1 of 2 | DONE |

| | | | |
|-------------|--------|--------|------|
| | Change | More | EDIT |
| SAVE | Prefix | 1 of 2 | DONE |

Receiver Mode

| | | | | | |
|----------------|--------|-------|-------|-------|------|
| | More | Limit | | EDIT | EDIT |
| DISPLAY | 1 of 2 | Lines | ... * | LIMIT | DONE |

| | | | | |
|----------------|--------|--------|--------|------|
| | More | Change | More | EDIT |
| DISPLAY | 1 of 2 | Prefix | 1 of 2 | DONE |

| | | | | | |
|--------------|--------|-------|-------|-------|------|
| | More | Limit | | Edit | EDIT |
| SETUP | 1 of 3 | Lines | ... * | limit | DONE |

| | | | | |
|--------------|--------|----------|-------|------|
| | More | Correctn | | EDIT |
| SETUP | 1 of 3 | Factors | ... † | DONE |

Signal Analysis Mode

| | | | | | | |
|----------------|--------|-------|-------|-------|--------|------|
| | More | Limit | Edit | | More | EDIT |
| DISPLAY | 1 of 2 | Lines | Limit | ... § | 1 of 2 | DONE |

| | | | | | | |
|--------------|--------|-------|-------|-------|--------|------|
| | More | Limit | Edit | | More | EDIT |
| SETUP | 1 of 3 | Lines | Limit | ... § | 1 of 2 | DONE |

* Either **Limit 1** or **Limit 2** can be used to complete the key path.

† Any of the following groups of softkeys can be used to complete the key path:

Antenna Factors EDIT ANTENNA, or Cable Factors EDIT CABLE,
or Other Factors EDIT OTHER.

§ Any of the following can be used to complete the key path:

EDIT UPPER, EDIT LOWER, EDIT UP/LOW, or EDIT MID/DELT.

Related Programming Command

none

EDIT
FLATNESS

Softkey that allows flatness-correction constants to be viewed or modified. This is a service calibration function and is for service use only.

Key Path

(CALIBRATE) More More Service Flatness EDIT
1 of 3 2 of 3 Cal Data FLATNESS

Related Programming Command

none

EDIT
LAST

Softkey that starts the DLP editor function and allows the most recent item that was being edited, in the DLP editor buffer, to be accessed again. The item will not be in the user memory of the instrument until it is processed by the SAVE EDIT softkey. The DLP editor memory remains intact when the instrument is preset and when it is powered off.

Key Path

(RECALL) Recall Catalog EDIT
Internal Internal ... * Editor LAST

(SAVE) Save Catalog EDIT
Internal Internal ... * Editor LAST

* Any of the following can be used to complete the key path:

CATALOG ALL, CATALOG VARIABLES, or CATALOG PREFIX.

Related Programming Command

none

**Edit
Limit**

Signal analysis mode only.

Softkey that allows you to edit the current limit-line tables by accessing **Edit Upper**, **Edit Lower**, **Edit Up/Low**, and **Edit Mid/Delt**. Use **PURGE LIMITS** under any of the above edit menus to dispose of the current limit-line table.

Key Path

(DISPLAY) More Limit Edit
1 of 2 Lines Limit

(SETUP) More Limit Edit
1 of 3 Lines Limit

Related Programming Command

none

**EDIT
LIMIT**

Receiver mode only.

Softkey that allows you to edit the current limit-line tables for limit line 1 or limit line 2. Use **DELETE LIMITS** under this menu to dispose of the current limit-line table.

Key Path

(DISPLAY) More Limit EDIT
1 of 2 Lines ... * LIMIT

(SETUP) More Limit EDIT
1 of 3 Lines ... * LIMIT

* Either **Limit 1** or **Limit 2** can be used to complete the key path.

Related Programming Command

none

**EDIT
LIST**

Softkey that accesses a menu to edit signal marking functions.

Key Path

(TEST) More EDIT
1 of 3 LIST

Related Programming Command

none

EDIT
LOWER

Signal analysis mode only.

Softkey that allows you to view or edit the lower limit-line table. Up to 30 entries are allowed for the lower limit-line table. With the lower limit-line table format, the coordinates for the lower limit-line are specified, but none are specified for the upper limit line. Even if upper limit-line values exist or the values had been entered as an upper and lower limit-line table, the lower limit-line values are treated as a separate table from the upper limit-line values. The lower limit-line entries can have independent frequency (or time) and amplitude coordinates from upper limit-line table entries.

Key Path

| | | | | |
|-----------|--------|-------|-------|-------|
| | More | Limit | Edit | EDIT |
| (DISPLAY) | 1 of 2 | Lines | Limit | LOWER |

| | | | | |
|---------|--------|-------|-------|-------|
| | More | Limit | Edit | EDIT |
| (SETUP) | 1 of 3 | Lines | Limit | LOWER |

Related Programming Command

LIMIMODE

EDIT
MID/DELT

Signal analysis mode only.

Softkey that allows you to view or edit the upper and lower limit-line tables simultaneously. These tables are edited by entering a middle amplitude value and an amplitude deviation. Up to 30 entries are allowed for the upper and lower limit-line tables. Like the upper and lower limit-line table format, the mid/delta limit-line table format provides a means of specifying the upper and lower limit lines at the same time. Unlike the upper and lower table format, the amplitude values are specified as a middle amplitude value with a delta (the upper and lower limit lines are drawn equal positive and negative distance from the middle amplitude).

With the mid/delta format the frequency (or time), and the middle amplitude plus the delta comprise the upper limit line; the frequency (or time), and the middle amplitude minus the delta comprise the lower limit line. The difference between the mid/delta and the upper/lower format is the way the amplitude values are entered; the frequency (time) coordinate begins a segment regardless of the format chosen. The mid/delta format can be used if the upper and lower limit lines are symmetrical with respect to the amplitude axis. An upper and lower amplitude component are specified for every frequency (or time) component.

Key Path

| | | | | |
|-----------|--------|-------|-------|----------|
| | More | Limit | Edit | EDIT |
| (DISPLAY) | 1 of 2 | Lines | Limit | MID/DELT |

| | | | | |
|---------|--------|-------|-------|----------|
| | More | Limit | Edit | EDIT |
| (SETUP) | 1 of 3 | Lines | Limit | MID/DELT |

Related Programming Command

LIMIMODE

EDIT
OTHER

Softkey that accesses the ampcor editor to edit correction factors for devices other than antennas and cables.

Key Path

| | | | | |
|---------|--------|----------|---------|-------|
| | More | Correctn | Other | EDIT |
| (SETUP) | 1 of 3 | Factors | Factors | OTHER |

Related Programming Command

AMPCOR

EDIT PA
FLTNESS

Softkey that allows the service center or factory to view the preamp on flatness data of the instrument.

Note

The service password must be entered to execute this command.

Key Path

| | | | | | |
|-------------|--------|--------|---------|----------|----------|
| | More | More | Service | Flatness | EDIT PA |
| (CALIBRATE) | 1 of 3 | 2 of 3 | Cal | Data | FLATNESS |

Related Programming Command

none

EDIT
UP/LOW

Signal analysis mode only.

Softkey that allows you to view or edit the upper and lower limit-line tables simultaneously. Up to 30 entries are allowed for the upper and lower limit-line tables. With the upper and lower limit-line table format, the upper and lower limit-lines can be entered at the same time.

With the upper and lower limit-line format, the frequency (or time), upper amplitude, and lower amplitude are specified. The frequency (or time) and upper amplitude value comprise the coordinate point

for the upper limit line, the frequency (or time) and lower amplitude value comprise the coordinate point for the lower limit line. It is not necessary to specify both an upper and lower amplitude component for every frequency (or time) component.

Key Path

| | | | | |
|-----------|--------|-------|-------|--------|
| | More | Limit | Edit | EDIT |
| (DISPLAY) | 1 of 2 | Lines | Limit | UP/LOW |

| | | | | |
|---------|--------|-------|-------|--------|
| | More | Limit | Edit | EDIT |
| (SETUP) | 1 of 3 | Lines | Limit | UP/LOW |

Related Programming Command

LIMIMODE

EDIT
UPPER

Signal analysis mode only.

Softkey that allows you to view or edit the upper limit-line table. Up to 30 entries are allowed for the upper limit-line table. With the upper limit-line table format, the coordinates of the upper limit line are specified, but none are specified for the lower limit line. Even if lower limit-line values exist or the values had been entered as an upper and lower limit-line table, the upper limit-line values are treated as a separate table from the lower limit-line values. The upper limit-line entries can have independent frequency (or time) and amplitude coordinates from lower limit-line table entries.

Key Path

| | | | | |
|-----------|--------|-------|-------|-------|
| | More | Limit | Edit | EDIT |
| (DISPLAY) | 1 of 2 | Lines | Limit | UPPER |

| | | | | |
|---------|--------|-------|-------|--------|
| | More | Limit | Edit | EDIT |
| (SETUP) | 1 of 3 | Lines | Limit | UPPPER |

Related Programming Command

LIMIMODE

EDIT
UPR LWR

Signal analysis mode only.

Softkey that selects upper or lower limit-line tables. It switches to the limit-line table that is not currently being edited.

Key Path

| | | | | | |
|-----------|--------|-------|-------|-------|---------|
| | More | Limit | Edit | | EDIT |
| (DISPLAY) | 1 of 2 | Lines | Limit | ... * | UPR LWR |

| | | | | | |
|---------|--------|-------|-------|-------|---------|
| | More | Limit | Edit | | EDIT |
| (SETUP) | 1 of 3 | Lines | Limit | ... * | UPR LWR |

* Either `EDIT UPPER` or `EDIT LOWER` can be used to complete the key path.

Related Programming Command

none

Editor

Softkey that accesses the menu of down loadable program (DLP) editor softkeys. Programming commands can be used to write a program to control the instrument. The built-in DLP editor uses the instrument rather than an external computer to create, view, or edit programs. These programs can then be sent to the command parser of the instrument, which is similar to outputting them to the instrument from an external computer.

Key Path

`RECALL` `Recall` `Catalog`
`Internal` `Internal` ... * `Editor`

`SAVE` `Save` `Catalog`
`Internal` `Internal` ... * `Editor`

* Any of the following can be used to complete the key path.
`CATALOG ALL`, `CATALOG VARIABLES`, or `CATALOG PREFIX`.

Related Programming Command

none

EMI RECEIVER

Softkey that configures the instrument as an EMI receiver.

Key Path

`MODE` `EMI`
`RECEIVER`

Related Programming Command

none

EPSON
MX

Softkey that specifies EPSON MX as the printer connected to the output port.

Key Path

(CONFIG) Print Printer More More EPSON
Config Type 1 of 3 2 of 3 MX

Related Programming Command

PRNTTYPE

ERASE
STATEALL

Softkey that disposes of any or all user-defined variables.

Key Path

(CONFIG) More Dispose ERASE
1 of 3 User Mem STATEALL

Related Programming Command

none

ERASE
TRACEALL

Softkey that disposes of any or all user-defined traces.

Key Path

(CONFIG) More Dispose ERASE
1 of 3 User Mem TRACEALL

Related Programming Command

none

ERRORS

Softkey that activates the error portion of the display screen for color editing.

Key Path

(DISPLAY) Display Adjust Edit More
Config Color Colors 1 of 3 ERRORS

Related Programming Command

SETC

EXECUTE TITLE

Softkey that executes a programming command displayed in the screen title area of the instrument. The **Change Title** function can be used to print programming commands in the screen title area of the display. The commands can then be executed from the front panel of the instrument, without an external computer, by pressing the **EXECUTE TITLE** softkey.

Key Path

| | | | | |
|------------------|--------|--------|---------|---------|
| | More | More | Service | EXECUTE |
| CALIBRATE | 1 of 3 | 2 of 3 | Cal | TITLE |

Related Programming Command

none

EXIT

Softkey that exits the **EDIT FLATNESS** menu. This is a service calibration function and is designed for service use only.

Key Path

| | | | | | | |
|------------------|--------|--------|---------|----------|------|------|
| | More | More | Service | Flatness | | |
| CALIBRATE | 1 of 3 | 2 of 3 | Cal | Data | More | EXIT |

Related Programming Command

none

EXIT CATALOG

Softkey that returns the instrument to the state it was in before the current catalog function was invoked. It clears the catalog display and returns to a normal display.

Key Path

Receiver Mode

| | | | | |
|----------------|--------|-------|--------|---------|
| | More | Limit | RECALL | EXIT |
| DISPLAY | 1 of 2 | Lines | LIMITS | CATALOG |

| | | | | |
|--------------|--------|-------|--------|---------|
| | More | Limit | RECALL | EXIT |
| SETUP | 1 of 3 | Lines | LIMITS | CATALOG |

Signal Analysis Mode

| | | | |
|---------------|--------|-------|---------|
| | Recall | | EXIT |
| RECALL | Disk | ... * | CATALOG |

| | | | | |
|---------------|--------|--------|-------|---------|
| | Recall | More | | EXIT |
| RECALL | Disk | 1 of 2 | ... † | CATALOG |

| | | | | |
|---------------|----------|----------|---|---------|
| | Recall | Catalog | | EXIT |
| RECALL | Internal | Internal | § | CATALOG |

| | | | | |
|---------|----------|----------|---------|---------|
| | Save | CATALOG | EXIT | |
| (SAVE) | Disk | DISK | CATALOG | |
| | Save | Catalog | EXIT | |
| (SAVE) | Internal | Internal | ... § | CATALOG |
| | RECALL | EXIT | | |
| (SETUP) | SETUP | CATALOG | | |
| | More | Save/Rcl | RECALL | EXIT |
| (TEST) | 1 of 3 | List | LIST | CATALOG |

* Any of the following can be used to complete the key path.

CATALOG DISK, RECALL SETUP, RECALL LIST, RECALL LIMITS
or RECALL ANTENNA.

† Any of the following can be used to complete the key path.

RECALL CABLE, RECALL OTHER, or RECALL TRACE.

§ Any of the following can be used to complete the key path.

CATALOG ALL, CATALOG VARIABLES, CATALOG PREFIX, or
CATALOG REGISTER.

Related Programming Command

none

EXIT
EDIT

Softkey that exits the annotation editor.

Key Path

| | | |
|----------|----------|------|
| | EDIT | EXIT |
| (OUTPUT) | ANNOTATN | EDIT |

Related Programming Command

EXITANNOT

EXIT
GRAPH

Softkey that exits the SAVE LIN GRAPH or SAVE LOG GRAPH report graph functions.

Key Path

| | | | | |
|--------|--------|----------|-----------|-------|
| | More | Save/Rcl | SAVE | EXIT |
| (TEST) | 1 of 3 | List | LIN GRAPH | GRAPH |
| | More | Save/Rcl | SAVE | EXIT |
| (TEST) | 1 of 3 | List | LOG GRAPH | GRAPH |

Related Programming Command

SIGGRAPH

EXIT
LAST CAL

Softkey that exits the LAST CAL menu.

Key Path

| | | | |
|-------------|--------|----------|----------|
| | More | | EXIT |
| (CALIBRATE) | 1 of 3 | Last Cal | LAST CAL |

Related Programming Code

none

EXIT
MEASURE

Softkey that exits the MEAS STEPPED menu.

Key Path

| | | | | |
|--------|--------|--------|---------|---------|
| | More | More | MEAS | EXIT |
| (TEST) | 1 of 3 | 2 of 3 | STEPPED | MEASURE |

| | | | | | |
|--------|--------|--------|---------|------|---------|
| | More | More | MEAS | | EXIT |
| (TEST) | 1 of 3 | 2 of 3 | STEPPED | STOP | MEASURE |

| | | | | | |
|--------|--------|--------|---------|------|---------|
| | More | More | MEAS | FREQ | EXIT |
| (TEST) | 1 of 3 | 2 of 3 | STEPPED | STEP | MEASURE |

Related Programming Command

none

EXIT
SHOW

Softkey that exits the SHW INST CONFIG function.

Key Path

| | | | | |
|----------|--------|--------|----------|------|
| | More | More | SHW INST | EXIT |
| (CONFIG) | 1 of 3 | 2 of 3 | CONFIG | SHOW |

Related Programming Command

HAVE, ID, REF, SER

EXTERNAL

Softkey that activates the trigger condition that allows the next sweep to start when an external voltage (connected to EXT TRIG INPUT on the rear panel) passes through approximately 1.5 volts. The external trigger signal must be a 0 V to +5 V TTL signal.

Key Path

TRIG EXTERNAL

Related Programming Command

TM

EXTERNAL PREAMPG

Softkey that adds a positive or negative preamplifier gain value, which is subtracted from the displayed signal. EXTERNAL PREAMPG is similar to the REF LVL OFFSET ; however, with the EXTERNAL PREAMPG , the attenuation may be changed depending on the preamplifier gain entered. A preamplifier gain offset is used for measurements that require an external preamplifier or long cables. The offset is subtracted from the amplitude readout so that the displayed signal level represents the signal level at the input of the preamplifier. The preamplifier gain offset is displayed at the top left hand-side of the screen and is removed by entering zero. The preamplifier gain offset is entered using the data keys. Press CAL STORE if you want the instrument to use the current preamplifier gain offset when power is turned on. Preamplifier gain offset is set to zero when DEFAULT CONFIG is pressed. The preamplifier gain value is not affected by an instrument preset.

Key Path

More EXTERNAL
AMPLITUDE 1 of 3 PREAMPG

Related Programming Command

PREAMPG

FAST STP ON OFF

Softkey that determines how stepped measurements are made. When OFF is selected, the MEAS STEPPED softkey performs a stepped measurement between the specified start and stop frequencies in increments set by the FREQ STEP softkey measuring all the selected detectors to the full accuracy of the instrument. When ON is selected and a limit margin is on (MARGIN # ON OFF), only the steps where the peak amplitude exceeds the limit margin are measured using the selected detectors. Using this softkey under normal conditions results in faster measurements due to the limited number of signals being measured.

Key Path

TEST More 1 of 3 More 2 of 3 FAST STP ON OFF

SETUP More 1 of 3 FAST STP ON OFF

Related Programming Command

none

FFT MEAS

This softkey is only available when LIN is selected for the SWEEP LOG LIN softkey.

Softkey that activates a discrete fast Fourier transform based on the current setup. For additional information refer to Chapter 6, Making EMI Diagnostic Measurements, in the *EMI Receiver Series User's Guide*.

Key Path

MEAS/USER FFT MEAS

Related Programming Command

FFT

FINE TUNE DAC

Softkey that displays the output of the YTO fine-tune DAC, which is produced on the A7 analog interface assembly. This is a service diagnostic function and is for service use only.

Key Path

CALIBRATE More 1 of 3 More 2 of 3 Service Diag More 1 ... More 3
FINE
TUNE DAC

Related Programming Command

none

FLAT

Softkey that draws a zero-slope line between the coordinate point of the current segment and the coordinate point of the next segment, producing limit-line values equal in amplitude for all frequencies between the two points. If the amplitude values of the two segments differ, the limit line “steps” to the frequency value of the second segment.

Key Path

Receiver Mode

| | | | | | | |
|----------------|--------|-------|-------|-------|--------|------|
| | More | Limit | | EDIT | Select | |
| DISPLAY | 1 of 2 | Lines | ... * | LIMIT | Type | FLAT |

| | | | | | | |
|--------------|--------|-------|-------|-------|--------|------|
| | More | Limit | | EDIT | Select | |
| SETUP | 1 of 3 | Lines | ... * | LIMIT | Type | FLAT |

Signal Analysis Mode

| | | | | | | |
|----------------|--------|-------|-------|-------|--------|------|
| | More | Limit | Edit | | Select | |
| DISPLAY | 1 of 2 | Lines | Limit | ... † | Type | FLAT |

| | | | | | | |
|--------------|--------|-------|-------|-------|--------|------|
| | More | Limit | Edit | | Select | |
| SETUP | 1 of 3 | Lines | Limit | ... † | Type | FLAT |

* Either **Limit 1** or **Limit 2** can be used to complete the key path.

† Any of the following can be used to complete the key path:

EDIT UPPER, **EDIT LOWER**, **EDIT UP/LOW**, or **EDIT MID/DELT**.

Related Programming Command

none

Flatness Data

Softkey that accesses a menu used to view or edit the flatness-correction constants. This is a service calibration function and is for service use only.

Key Path

| | | | | |
|------------------|--------|--------|---------|----------|
| | More | More | Service | Flatness |
| CALIBRATE | 1 of 3 | 2 of 3 | Cal | Data |

Related Programming Command

none

FM COIL DRIVE

Softkey that displays the output of the FM coil driver produced on the A7 analog interface assembly. This is a service diagnostic function and is for service use only.

Key Path

CALIBRATE More 1 of 3 More 2 of 3 Service Diag More 1 FM COIL DRIVE

Related Programming Command

none

FM GAIN

Softkey that adjusts the FM deviation display. The center graticule represents zero deviation. The top graticule is the positive deviation set by FM GAIN. The bottom graticule is the negative deviation set by FM GAIN. The range for FM gain is from 3 kHz to 1.175 MHz. The default value is 100 kHz. This is a service calibration function and is for service use only.

Key Path

CALIBRATE More 1 of 3 More 2 of 3 Service Diag More 1 ... More 4
FM
GAIN

SELECT FM
GAIN

Related Programming Command

FMGAIN

FM OFFSET

Softkey that adjusts the horizontal trace for center-screen with no modulation on the carrier. This is a service diagnostic function and is for service use only.

Key Path

CALIBRATE More 1 of 3 More 2 of 3 Service Diag More 1 ... More 4
FM
OFFSET

Related Programming Command

none

FM SPAN

Softkey that displays the FM_SPAN signal from the span dividers on the A7 Analog Interface assembly. This is a service diagnostic function and is for service use only.

Key Path

(CALIBRATE) More 1 of 3 More 2 of 3 Service Diag More 1 FM SPAN

Related Programming Command

none

FORMAT DOS DISK

Softkey that formats a 3.5 inch double-sided floppy disk in DOS format.

A DOS filename consists of a:

- prefix (optional)
- register number (required)
- file type descriptor (automatically supplied)

A DOS filename is defined as:

prefix = register #.file type descriptor
for example "PREFIX3.SIG"

The filename, excluding the extension, cannot exceed eight characters. The file type descriptor is a three letter extension such as, "SIG" for a signal list.

Key Path

(CONFIG) Disk Config FORMAT DOS DISK

Related Programming Command

FORMAT

FORMAT LIF DISK

Softkey that formats a 3.5 inch double-sided floppy disk in LIF format.

A LIF filename is defined as:

file type descriptor = prefix_register number
for example, "tPREFIX_3"

The filename cannot exceed eight characters. The file type descriptor is a single character preceding the prefix such as, "t" for a trace.

Key Path

Disk FORMAT
CONFIG Config LIF DISK

Related Programming Command

FORMAT

FREE RUN

Softkey that activates the trigger condition to start the next sweep as soon as possible after the last sweep.

Key Path

TRIG FREE RUN

Related Programming Command

TM

FREQ DIAG

Softkey that displays, in real-time, frequency diagnostic information for the local oscillator section. This is a service diagnostic function and is for service use only.

Key Path

More More Service
CALIBRATE 1 of 3 2 of 3 Diag More 1 ... More 4
FREQ
DIAG

Related Programming Command

none

FRQ DISC NORM OFF

Softkey that indicates the status of the frequency discriminator as a function of LO span. This is a service diagnostic function and is for service use only.

Key Path

More More Service
CALIBRATE 1 of 3 2 of 3 Diag More 1 ... More 4
FRQ DISC
NORM OFF

Related Programming Command

none

**FREQ
OFFSET**

Softkey that inputs a frequency offset value that is added to the frequency readout, to account for frequency conversions external to the instrument. Offset entries are added to all frequency readouts including marker, start frequency, and stop frequency. Entering an offset does not affect the trace. Offsets are not added to the span. Frequency offsets are entered using the data keys.

When a frequency offset is entered, its value is displayed on the top left side of the screen. To eliminate an offset, press **FREQ OFFSET** and 0 (**ENTER**). Pressing (**PRESET**) also sets the offset to zero.

Key Path

(**FREQUENCY**) **More** **FREQ**
1 of 2 **OFFSET**

Related Programming Command

FOFFSET

**FREQ SCL
LOG LIN**

Softkey that specifies whether the limit line is derived from a logarithmic or linear frequency axis. Underline LIN to set the frequency axis to linear or LOG to set the frequency axis to logarithmic.

Key Path

Receiver mode

(**DISPLAY**) **More** **Limit** **EDIT** **Select** **Select**
1 of 2 **Lines** ... * **LIMIT** **Type** **Axis**
AMPL SCL
LOG LIN

(**SETUP**) **More** **Limit** **EDIT** **Select** **Select**
1 of 3 **Lines** ... * **LIMIT** **Type** **Axis**
FREQ SCL
LOG LIN

Signal analysis mode

(**DISPLAY**) **More** **Limit** **Edit** **Select** **Select**
1 of 2 **Lines** **Limit** ... † **Type** **Axis**
FREQ SCL
LOG LIN

| | | | | | |
|---------|----------|-------|-------------|--------|--------|
| | More | Limit | Edit | Select | Select |
| (SETUP) | 1 of 3 | Lines | Limit ... † | Type | Axis |
| | FREQ SCL | | | | |
| | LOG LIN | | | | |

* Either **Limit 1** or **Limit 2** can be used to complete the key path.

† Any of the following can be used to complete the key path:
EDIT UPPER, **EDIT LOWER**, **EDIT UP/LOW**, or **EDIT MID/DELT**.

Related Programming Command

LIMIFRQSC

**FREQ
STEP**

Softkey that sets the size of the frequency step for stepped measurements.

Key Path

| | | | | |
|---------|--------|-------|--------|------|
| | More | Inst | More | FREQ |
| (SETUP) | 1 of 3 | Setup | 1 of 2 | STEP |

| | | | | |
|--------|--------|--------|---------|------|
| | More | More | MEAS | FREQ |
| (TEST) | 1 of 3 | 2 of 3 | STEPPED | STEP |

| | | | | |
|--------|--------|--------|---------|-----------|
| | More | More | MEAS | FREQ |
| (TEST) | 1 of 3 | 2 of 3 | STEPPED | STOP STEP |

Related Programming Command

none

FREQUENCY

Hardkey that activates the center-frequency or start-frequency function and accesses a menu of other frequency functions. The center frequency or start frequency value appears below the graticule on the screen.

Although the instrument allows entry of frequencies greater than the specified frequency range, using frequencies greater than the frequency span of the instrument is not recommended.

Note

When changing both the center frequency and the span, change the frequency first since the span can be limited by the frequency value.

Related Programming Command

none

FRQ SCAN
ON OFF

Softkey that reduces the signal span at the marker to zero span by performing an automatic zoom. When **FREQ SCAN ON OFF** is off, the instrument is restored to its previous setting with the exception of the marker which is placed at the same frequency as the zero scan (span) frequency.

Key Path

(TEST) FRQ SCAN
ON OFF

Related Programming Command

none

FULL
SPAN

Softkey that changes the instrument span to full span. The span can be limited if harmonic band lock (**BND LOCK ON OFF**) is set to ON.

Key Path

(SPAN) FULL
SPAN

Related Programming Command

FS

FULL
WHITE

Softkey that replaces the standard display screen with a full-sized white box. This is one of 18 test patterns that can be used for display-troubleshooting and screen-alignment procedures.

Key Path

(DISPLAY) Display Test FULL
Config Patterns WHITE

Related Programming Command

none

Gauss

Softkey that selects gauss as the transducer conversion units for the antenna amplitude-correction factors.

Key Path

More Correctn Antenna RECALL More
(SETUP) 1 of 3 Factors Factors ANTENNA 1 of 2
Antenna
Units Gauss

Related Programming Command

XUNITS

GEO DST TEST

Softkey that replaces the standard display screen with a geometric distortion test pattern. This is one of 18 test patterns that can be used for display-troubleshooting and screen-alignment procedures.

Key Path

Display Test GEO DST
(DISPLAY) Config Patterns TEST

Related Programming Command

none

GHIJKL

Softkey that accesses the menu used for selecting screen title or prefix characters G through L.

Key Access

(CAL), (CONFIG), (DISPLAY), (RECALL), (SAVE), or (SETUP)

Related Programming Command

none

GND REF DETECTOR

Softkey that displays the output of the analog-ground reference produced on the A16 processor/video assembly. This is a service diagnostic function and is for service use only.

Key Path

More More Service GND REF
(CALIBRATE) 1 of 3 2 of 3 Diag More 1 DETECTOR

Related Programming Command

none

GRAT
ON OFF

Softkey that turns the screen graticule on and off. This is helpful when alternative graphics are drawn on the screen through a remote controller and during plotting, when a graticule is not required.

Key Path

(DISPLAY) More GRAT
1 of 2 ON OFF

Related Programming Command

GRAT

GRATICUL

Softkey that activates the graticule portion of the display screen for color editing.

Key Path

(DISPLAY) Display Adjust Edit
Config Color Colors GRATICUL

Related Programming Command

SETC

GRAY
SCALE

Softkey that replaces the standard display screen with a test pattern. This is one of 18 test patterns that can be used for display-troubleshooting and screen-alignment procedures.

Key Path

(DISPLAY) Display Test More GRAY
Config Patterns 1 of 4 SCALE

Related Programming Command

none

GREEN

Softkey that changes the intensity of the green portion of the primary light source output for the display annotation, traces, graticule, and so on.

Key Path

| | | | | | |
|---------|---------|--------|--------|-----|-----------|
| | Display | Adjust | Edit | | HSL |
| DISPLAY | Config | Color | Colors | ... | RGB GREEN |

Related Programming Command

none

GREEN FILL

Softkey that replaces the standard display screen with a green box. This is one of 18 test patterns that can be used for display-troubleshooting and screen-alignment procedures.

Key Path

| | | | | | |
|---------|---------|----------|--------|--------|--------|
| | Display | Test | More | More | More |
| DISPLAY | Config | Patterns | 1 of 4 | 2 of 4 | 3 of 4 |
| | GREEN | | | | |
| | FILL | | | | |

Related Programming Command

none

GRID

Softkey that replaces the standard display screen with a grid pattern. This is one of 18 test patterns that can be used for display-troubleshooting and screen-alignment procedures.

Key Path

| | | | | | | |
|---------|---------|----------|--------|--------|--------|------|
| | Display | Test | More | More | More | |
| DISPLAY | Config | Patterns | 1 of 4 | 2 of 4 | 3 of 4 | GRID |

Related Programming Command

none

HALF
FILL

Softkey that replaces the standard display screen with half white screen. This is one of 18 test patterns that can be used for display-troubleshooting and screen-alignment procedures.

Key Path

| | | | |
|-----------|---------|----------|------|
| | Display | Test | HALF |
| (DISPLAY) | Config | Patterns | FILL |

Related Programming Command

none

HI VOLT
TEST

Softkey that replaces the standard display screen with a high voltage regulation test pattern. This is one of 18 test patterns that can be used for display-troubleshooting and screen-alignment procedures.

Key Path

| | | | |
|-----------|---------|----------|---------|
| | Display | Test | HI VOLT |
| (DISPLAY) | Config | Patterns | TEST |

Related Programming Command

none

HOLD

Softkey that deactivates the active function and blanks the active function text from the display. No data can be accidentally entered using the knob, step keys, or data keys. Activating another function will turn off the hold function.

Key Path

| | |
|-----------|------|
| (DISPLAY) | HOLD |
|-----------|------|

Related Programming Command

HD

HORIZ
LINES

Softkey that replaces the standard display screen with a horizontal lines. This is one of 18 test patterns that can be used for display-troubleshooting and screen-alignment procedures.

Key Path

| | | | | | |
|-----------|---------|----------|--------|--------|-------|
| | Display | Test | More | More | HORIZ |
| (DISPLAY) | Config | Patterns | 1 of 4 | 2 of 4 | LINES |

Related Programming Command

none

HSL
RGB

Softkey that accesses a menu to select one of the following: red, green, or blue (the three primary light sources that make up any color), hue (the pure color), saturation (the ratio of the pure color mixed with white), or luminosity (the brightness-per-unit area). When RGB is underlined, the softkeys **RED**, **GREEN**, and **BLUE** will be displayed. When HSL is underlined, the softkeys **HUE**, **SATUR-ATION**, and **LUMIN-OSITY** will be display.

Key Path

| | | | | | |
|----------------|---------|--------|--------|-----|-----|
| | Display | Adjust | Edit | | HSL |
| DISPLAY | Config | Color | Colors | ... | RGB |

Related Programming Command

SETC

HUE

Softkey that changes the hue (pure color) of the specified portion of the display annotation.

Key Path

| | | | | | |
|----------------|---------|--------|--------|-----|---------|
| | Display | Adjust | Edit | | HSL |
| DISPLAY | Config | Color | Colors | ... | RGB HUE |

Related Programming Command

SETC

IDNUM

Softkey that is used when the instrument is powered on the first time. It inputs the instrument model number and option information. This is a service calibration function and is for service use only.

Key Path

| | | | | | |
|------------------|--------|--------|---------|----------|-------|
| | More | More | Service | Flatness | |
| CALIBRATE | 1 of 3 | 2 of 3 | Cal | Data | IDNUM |

Related Programming Command

none

IF BW
AUTO MAN

Softkey that specifies the intermediate frequency bandwidth. When MAN is underlined, the coupling between sweep time and intermediate frequency bandwidth is disabled. When AUTO is underlined, coupling is reestablished.

Key Path

IF BW
(BW) AUTO MAN

Related Programming Command

IFBW, RB

IF GAINS

Softkey that displays the gain setting of the following: RF Atten, 3rd Conv DAC, 21.4 Gain, Cal Atten, Lin Gain, and NBW Sgain. This is a service calibration function and is for service use only.

Key Path

(CALIBRATE) More 1 of 3 More 2 of 3 Service Diag IF GAINS

Related Programming Command

none

INIT FLT

Softkey that is used when the instrument is powered on the first time. It sets the defaults for instrument flatness including the start and stop frequencies and the step size. All of the correction values are set to zero. This is a service calibration function and is for service use only.

Key Path

(CALIBRATE) More 1 of 3 More 2 of 3 Service Cal Flatness Data INIT FLT

Related Programming Command

none

INPT LCK
ON OFF

Available only for an EMI receiver.

Softkey that limits tuning to values within the currently selected input path. For example, when input lock is on, and a stop frequency is selected out of the range of the currently selected input path, the actual stop frequency used will be the highest possible value allowed by the selected input path.

Key Path

More INPT LCK
1 of 2 ON OFF
(FREQUENCY)

Related Programming Command

RFLINK

(INPUT)

Hardkey that accesses a menu to specify the input signal routing path through the RF filter section.

Related Programming Command

RFIN

Input

Softkey that accesses a menu that allows switching the 300 MHz calibrator signal so that it is routed to the RF input of the instrument.

Key Path

More Inst
1 of 3 Setup Input
(SETUP)

Related Programming Command

none

INPUT 1

Softkey that displays the filter calibration data for input 1. This is a service calibration function and is for service use only.

Key Path

More More Service Display
1 of 3 2 of 3 Diag Sys Data INPUT 1
(CALIBRATE)

Related Programming Command

none

INPUT 1
9k-50M

Softkey that specifies the 9 kHz to 50 MHz input path (INPUT 1) as the signal routing path of the RF filter section.

Key Path

(INPUT) INPUT 1
9k-50M

(SETUP) More Inst INPUT 1
1 of 3 Setup Input 9k-50M

Related Programming Command

RFIN

INPUT 1
PREAMP

Softkey that displays the calibration data for input 1, with the preamplifier on. This is a service calibration function and is for service use only.

Key Path

(CALIBRATE) More More Service Display INPUT 1
1 of 3 2 of 3 Diag Sys Data PREAMP

Related Programming Command

none

INPUT 2

Softkey that is for service use only.

Key Path

(CALIBRATE) More More Service Display
1 of 3 2 of 3 Diag Sys Data INPUT 2

Related Programming Command

none

INPUT 2
20M-2.9G

Softkey that specifies the 20 MHz to 2.9 GHz input path (INPUT 2) as the signal routing path of the RF filter section.

Key Path

(INPUT) INPUT 2
20M-2.9G

(SETUP) More Inst INPUT 2
1 of 3 Setup Input 20M-2.9G

Related Programming Command

RFIN

INPUT 2
1-6.5G

For an HP 8546A/HP 85462A only.

Softkey that specifies the 1 MHz to 6.5 GHz input path (INPUT 2) as the signal routing path of the HP 85420E/HP 85460A RF filter section.

Key Path

| | | | | | |
|---------|---------|-------|-------|---------|--|
| | INPUT 2 | | | | |
| (INPUT) | 1-6.5G | | | | |
| | More | Inst | | INPUT 2 | |
| (SETUP) | 1 of 3 | Setup | Input | 1-6.5G | |

Related Programming Command

RFIN

INPUT 2
BYPASS

Softkey that specifies the bypass input path (INPUT 2) as the signal routing path of the HP 85420E/HP 85460A RF filter section.

Key Path

| | | | | | |
|---------|---------|-------|-------|---------|--|
| | INPUT 2 | | | | |
| (INPUT) | BYPASS | | | | |
| | More | Inst | | INPUT 2 | |
| (SETUP) | 1 of 3 | Setup | Input | BYPASS | |

Related Programming Command

BYPASS, RFIN

INPUT 2
PREAMP

Softkey that is for service use only.

Key Path

| | | | | | |
|-------------|--------|--------|---------|----------|---------|
| | More | More | Service | Display | INPUT 2 |
| (CALIBRATE) | 1 of 3 | 2 of 3 | Diag | Sys Data | PREAMP |

Related Programming Command

none

INPUT Z
50Ω 75Ω

Softkey that sets the input impedance for voltage-to-power conversions. The impedance you select is for computational purposes only, since the actual impedance of 50Ω is set by internal hardware. The preset value can be changed by using a service function. Select the computational input impedance by pressing INPUT Z 50Ω 75Ω or by entering 50 or 75 using the data keys.

Key Path

More INPUT Z
(AMPLITUDE) 1 of 3 50Ω 75Ω

Related Programming Command

INZ

Inst
Setup

Softkey that accesses a menu which sets up the instrument for making EMI measurements.

Key Path

More Inst
(SETUP) 1 of 3 Setup

Related Programming Command

none

INTENSITY

Softkey that changes the intensity or contrast of the display. The intensity level is shown on the top left-hand side of the screen. Use the knob or step keys to adjust the intensity level.

Key Path

Display
(DISPLAY) Config INTENSITY
(DISPLAY) INTENSITY

Related Programming Command

none

**INTERNAL
-> STATE**

Softkey that recalls the saved instrument state from the selected state register. To recall a state, press **INTERNAL -> STATE** and use the data keys to enter a state register number (valid state register numbers are 1 through 9). State register 9 contains a previous state; state register 0 contains the current state. If windows are being used, the instrument state can only be recalled into the active window.

Key Path

| | | |
|-----------------|----------|----------|
| | Recall | INTERNAL |
| (RECALL) | Internal | -> STATE |

Related Programming Command

RCLS

**Internal
-> Trace**

Softkey that accesses a menu that allows you to either; select the trace in which the trace data is to be recalled (trace A, trace B, or trace C), or recall the current limit-line tables. When recalling a trace, select the trace in which the trace data is to be recalled, enter the trace register number, and press **(ENTER)**. If windows are being used, only the trace of the active window can be recalled.

When recalling a limit-line table, press **LIMIT LINES**, enter the trace register number, and press **(ENTER)**. Valid trace register numbers are 0 through the maximum register number. The maximum register number is the number displayed after **MAX REG # =** during a save or recall operation. If a screen title is present, it is recalled with the trace data (but not with the limit-line table). If the screen title does not exceed 34 characters, the time and date when the data was stored will also be displayed. **INVALID SAVEREG** is displayed if data has not been stored in the trace register.

Key Path

| | | |
|-----------------|----------|----------|
| | Recall | Internal |
| (RECALL) | Internal | -> Trace |

Related Programming Command

RCLT

LASERJET

Softkey that specifies an HP LaserJet as the printer connected to the output port.

Key Path

| | | | |
|----------|--------|---------|----------|
| | Print | Printer | |
| (CONFIG) | Config | Type | LASERJET |

Related Programming Command

PRNTTYPE

LASERJET II

Softkey that specifies an HP LaserJet II as the printer connected to the output port.

Key Path

| | | | |
|----------|--------|---------|----------|
| | Print | Printer | LASERJET |
| (CONFIG) | Config | Type | II |

Related Programming Command

PRNTTYPE

LASERJET III

Softkey that specifies an HP LaserJet III as the printer connected to the output port.

Key Path

| | | | |
|----------|--------|---------|----------|
| | Print | Printer | LASERJET |
| (CONFIG) | Config | Type | III |

Related Programming Command

PRNTTYPE

Last Cal

Available only for an EMI receiver.

Softkey that displays the date of the last calibration for both the receiver RF section and the RF filter section.

Key Path

| | | |
|-------------|--------|------|
| | More | Last |
| (CALIBRATE) | 1 of 3 | Cal |

Related Programming Command

none

Last Hrd
Key Menu

Softkey that changes the menu to the last hardkey menu that was active. This provides quick access between two separate hardkey menus.

Key Path

(SETUP) More 1 of 3 More 2 of 3 Last Hrd Key Menu

Related Programming Command

LASTKEYMENU

LAST
SPAN

Softkey that changes the frequency span of the instrument to the previous span setting.

Key Path

(SPAN) LAST SPAN

Related Programming Command

LSPAN

Limit 1

Receiver mode only.

Softkey that accesses the menu for displaying, testing, deleting, and editing of limit 1 and its corresponding margin.

Key Path

(DISPLAY) More 1 of 2 Limit Lines Limit 1

(SETUP) More 1 of 3 Limit Lines Limit 1

Related Programming Command

LIMINUM

LIMIT 1
ON OFF

Receiver mode only.

Softkey that displays limit line 1 when ON is underlined.

Key Path

(DISPLAY) More 1 of 2 Limit Lines Limit 1 LIMIT 1 ON OFF

(SETUP) More 1 of 3 Limit Lines Limit 1 LIMIT 1 ON OFF

Related Programming Command

LIMILINESTA

Limit 2

Receiver mode only.

Softkey that accesses a menu for displaying, testing, deleting, and editing of limit 2 and its corresponding margin.

Key Path

(DISPLAY) More 1 of 2 Limit Lines Limit 2

(SETUP) More 1 of 3 Limit Lines Limit 2

Related Programming Command

LIMINUM

LIMIT 2
ON OFF

Receiver mode only.

Softkey that displays limit line 2 when ON is underlined.

Key Path

(DISPLAY) More 1 of 2 Limit Lines Limit 2 LIMIT 2 ON OFF

(SETUP) More 1 of 3 Limit Lines Limit 2 LIMIT 2 ON OFF

Related Programming Command

LIMILINESTA

LIMIT
LINE 1

Softkey that activates the limit line 1 portion of the display screen for color editing.

Key Path

| | | | | | |
|-----------|---------|--------|--------|--------|--------|
| | Display | Adjust | Edit | More | LIMIT |
| (DISPLAY) | Config | Color | Colors | 1 of 3 | LINE 1 |

Related Programming Command

SETC

Limit
Lines

Softkey that accesses the limit-line menus.

Key Path

| | | |
|-----------|--------|-------|
| | More | Limit |
| (DISPLAY) | 1 of 2 | Lines |

| | | |
|---------|--------|-------|
| | More | Limit |
| (SETUP) | 1 of 3 | Lines |

Related Programming Command

none

LIMIT
LINES

Softkey that saves or recalls limit-line tables in a trace register to or from a floppy disk or internal memory.

When accessed by (SAVE), the current limit-line table is stored to a trace register in internal memory or on a floppy disk. To save a limit-line table press, LIMIT LINES . REGISTER # and PREFIX= are displayed on the screen. Use the data keys to enter the desired register number then press (ENTER). The message Saving to :FILENAME is displayed. The limit-line table has now been saved to a disk.

When accessed by (RECALL), the limit-line table will be recalled from a trace register in internal memory. To recall a limit-line table press, LIMIT LINES , use the step keys or knob to highlight the desired file then press LOAD FILE .

Key Path

| | | | |
|----------|----------|----------|-------|
| | Recall | Internal | LIMIT |
| (RECALL) | Internal | -> Trace | LINES |

| | | | |
|--------|----------|-----------|-------|
| | Save | Trace | LIMIT |
| (SAVE) | Internal | -> INTRNL | LINES |

| | | | | |
|--------|------|--------|---------|-------|
| | Save | More | Trace | LIMIT |
| (SAVE) | Disk | 1 of 2 | -> Disk | LINES |

Related Programming Command

none

LIMITS
-> DISK

Softkey that saves the current limit-line data to a floppy disk. To save a limit line press, LIMITS -> DISK. REGISTER # and PREFIX= are displayed on the screen. Use the data keys to enter the desired register number then press **ENTER**. The message Saving to :FILENAME is displayed. The limit line has now been saved to a disk.

Key Path

Save LIMITS
SAVE Disk -> DISK

Related Programming Command

none

LIMITS
FIX REL

Signal analysis mode only.

Softkey that allows you to choose fixed or relative type of limit lines. The fixed (FIX) type uses the current limit line as a reference with fixed frequency and amplitude values. The relative (REL) setting causes the current limit-line value to be relative to the displayed center frequency and reference-level amplitude values. When limit lines are specified with time, rather than frequency, the relative setting only affects the amplitude values. The current amplitude values will be relative to the displayed reference-level amplitude, but the time values will always start at the left edge of the graticule.

As an example, assume you have a frequency limit line. If the limit line is specified as fixed, entering a limit-line segment with a frequency coordinate of 300 MHz displays the limit-line segment at 300 MHz. If the same limit-line table is specified as relative, it is displayed relative to the center frequency and reference level of the instrument. If the center frequency is at 1.2 GHz, a relative limit-line segment with a frequency coordinate of 300 MHz will display the limit-line segment at 1.5 GHz. If the amplitude component of the relative limit-line segment is -10 dB, then -10 dB is added to the reference level value to obtain the amplitude of the given component (reference level offset included).

RELATIVE is displayed in the limit-line table when the limit-line type is relative; FIXED is displayed when limit-line type is fixed.

A limit line entered as fixed may be changed to relative, and one entered as relative may be changed to fixed. When changing between fixed and relative limit-lines, the frequency and amplitude values in the limit-line table change so that the limit line remains in the same position for the current frequency and amplitude settings of the

instrument. If a time and amplitude limit line is used, the amplitude values change but the time values remain the same.

Key Path

| | | | | | | |
|-----------|--------|-------|-------|-------|--------|---------|
| | More | Limit | Edit | | More | LIMITS |
| (DISPLAY) | 1 of 2 | Lines | Limit | ... * | 1 of 2 | FIX REL |
| | More | Limit | Edit | | More | LIMITS |
| (SETUP) | 1 of 3 | Lines | Limit | ... * | 1 of 2 | FIX REL |

* Any of the following can be used to complete the key path:
 EDIT UPPER, EDIT LOWER, EDIT UP/LOW, or EDIT MID/DELT.

Related Programming Command

LIMIREL

LIMITS
 FRQ TIME

Signal analysis mode only.

Softkey that selects whether limit lines will be entered using frequency or sweep time to define the segments. Limit lines can be created by the user to test trace data. They can be specified as a table of limit-line segments of amplitude versus frequency, or of amplitude versus time. Time values are evaluated with respect to the spectrum analyzer sweep time. A time value of zero corresponds to the start of the sweep, which is the left edge of the graticule.

Switching the limit line definition between frequency and time will erase the current limit-line table. The message If you are sure, press key again to purge data will appear. Press LIMITS FRQ TIME again to purge the limit-line table and switch between frequency and time.

Key Path

| | | | | |
|-----------|--------|-------|-------|----------|
| | More | Limit | Edit | LIMITS |
| (DISPLAY) | 1 of 2 | Lines | Limit | FRQ TIME |
| | More | Limit | Edit | LIMITS |
| (SETUP) | 1 of 3 | Lines | Limit | FRQ TIME |

Related Programming Command

LIMIFT

LINE

Softkey that activates the trigger condition that allows the next sweep to be synchronized with the next cycle of the line voltage.

Key Path

TRIG LINE

Related Programming Command

TM

LINEARITY

Softkey that replaces the standard display screen with a linearity test pattern. This is one of 18 test patterns that can be used for display-troubleshooting and screen-alignment procedures.

Key Path

DISPLAY Display Test Config Patterns LINEARITY

Related Programming Command

none

LINEARITY CHECK

Hardkey that modifies the input RF attenuation to determine if a measured signal level is undergoing compression. **LINEARITY CHECK** is designed to be used with the Marker Subsystem in order to measure a specific signal level at different RF attenuation values.

Related Programming Command

LINCHK

**LIN
ON OFF**

Softkey that turns on or off the generation of a linear graph of the signal list. The linear graph is sent to the printer or plotter when **OUTPUT REPORT** is executed.

Key Path

OUTPUT Define Report LIN ON OFF

Related Programming Command

RPTDEF

LIST
-> DISK

Softkey that saves the current signal list to a floppy disk. To save a signal list press, LIST -> DISK . REGISTER # and PREFIX= are displayed on the screen. Use the data keys to enter the desired register number then press (ENTER). The message Saving to :FILENAME is displayed. The signal list has now been saved to a disk.

Key Path

| | | |
|--------|------|---------|
| | Save | LIST |
| (SAVE) | Disk | -> DISK |

Related Programming Command

none

LIST
ON OFF

Softkey that enables or disables the generation of a tabular listing of a signal list. The listing is sent to a printer when OUTPUT REPORT is executed.

Key Path

| | | |
|----------|--------|--------|
| | Define | LIST |
| (OUTPUT) | Report | ON OFF |

Related Programming Command

RPTDEF

LMT DISP
Y N AUTO

Signal analysis mode only.

Softkey that displays any portion of the limit lines that are currently within the display boundary of the spectrum analyzer. If Y (yes) is underlined the limit lines are displayed. If N (no) is underlined they are not displayed. If AUTO is underlined, the display of the limit lines is dependent on the limit test function. The limit lines will be displayed while the limit test function is turned on, otherwise they will be turned off.

Key Path

| | | | |
|-----------|--------|-------|----------|
| | More | Limit | LMT DISP |
| (DISPLAY) | 1 of 2 | Lines | Y N AUTO |

| | | | |
|---------|--------|-------|----------|
| | More | Limit | LMT DISP |
| (SETUP) | 1 of 3 | Lines | Y N AUTO |

Related Programming Command

LIMIDISP

LMT TEST ON OFF

Softkey that turns the limit-line testing and (if **LMT DISP AUTO** is selected) turns the display of the limit lines on and off. When limit-line testing is enabled, every measurement sweep of trace A is compared to the limit lines.

Key Path

Receiver Mode

DISPLAY More Limit LMT TEST
1 of 2 Lines ... * ON OFF

SETUP More Limit LMT TEST
1 of 3 Lines ... * ON OFF

* Either **Limit 1** or **Limit 2** can be used to complete the key path.

Signal Analysis Mode

DISPLAY More Limit LMT TEST
1 of 2 Lines ON OFF

SETUP More Limit LMT TEST
1 of 3 Lines ON OFF

Related Programming Command

LIMIFAIL, LIMITEST

LOAD FILE

Softkey that loads a file from the disk in the disk drive or a register into instrument memory.

Use the step keys or knob to view sections of the directory, then press **LOAD FILE** to select the highlighted file or register.

Note

Use of the **LOAD FILE** softkey is not recommended for recalling limit-line tables or amplitude-correction factors stored in internal memory.

Key Path

RECALL Recall LOAD
Disk ... * FILE

RECALL Recall More LOAD
Disk 1 of 2 ... † FILE

RECALL Recall Catalog Catalog LOAD
Internal Internal Register FILE

SAVE Save CATALOG LOAD
Disk DISK FILE

| | | | | |
|---------|----------|----------|----------|------|
| | Save | Catalog | CATALOG | LOAD |
| (SAVE) | Internal | Internal | REGISTER | FILE |
| | RECALL | LOAD | | |
| (SETUP) | SETUP | FILE | | |
| | More | Correctn | | LOAD |
| (SETUP) | 1 of 3 | Factor | ... § | FILE |
| | More | Save/Rcl | RECALL | LOAD |
| (TEST) | 1 of 3 | List | LIST | FILE |

* Any of the following can be used to complete the key path:

CATALOG DISK, RECALL SETUP, RECALL LIST, RECALL LIMITS,
or RECALL ANTENNA.

† Any of the following can be used to complete the key path:

RECALL CABLE, RECALL OTHER, or RECALL TRACE.

§ Any of the following groups of softkeys can be used to complete the key path:

Antenna Factors RECALL ANTENNA, or Cable Factors RECALL CABLE,
or Other Factors RECALL OTHER.

Receiver Mode

| | | | | |
|-----------|--------|-------|--------|------|
| | More | Limit | RECALL | LOAD |
| (DISPLAY) | 1 of 2 | Lines | LIMITS | FILE |
| | More | Limit | RECALL | LOAD |
| (SETUP) | 1 of 3 | Lines | LIMITS | FILE |

Related Programming Command

LOAD

(LOCAL) Pressing (CONFIG) (LOCAL) after the instrument has been placed in the remote mode places the instrument in the local mode and enables front-panel control. During remote operation, “R” appears in the lower-right corner of the screen indicating remote and talk. A “T” or “L” may appear during remote operation, indicating talk or listen. Pressing the (CONFIG) key removes the “R” symbol in the lower-right corner.

LOG
ON OFF

Softkey that turns on or off the generation of a logarithmic graph of the signal list. The logarithmic graph is sent to the printer or plotter when **OUTPUT REPORT** is executed.

Key Path

Define LOG
OUTPUT Report ON OFF

Related Programming Command

RPTDEF

LOGF SPD
STD FAST

*This softkey is only available when LOG is selected for the **SWEEP LOG LIN** softkey.*

Softkey that selects between optimizing the frequency accuracy or minimizing the scan time. When “STD” is selected the frequency accuracy of the sweep is optimized. When “FAST” is selected the scan time of the sweep is minimized.

Note

Selecting the **LOGF SPD STD FAST** function has an effect on the minimum sweep time selected by the **SWP TIME AUTO MAN** function. The minimum sweep time is less than or equal to the minimum sweep time when **SWP TIME AUTO MAN (AUTO)** is selected.

Key Path

More LOGF SPD
FREQUENCY 1 of 2 STD FAST
LOGF SPD
SWEEP STD FAST

Related Programming Command

LOGSWEEPSPD

LUMIN-
OSITY

Softkey that changes the luminosity (the brightness-per-unit area) of the specified portion of the display annotation.

Key Path

Display Adjust Edit HSL LUMIN-
DISPLAY Config Color Colors ... RGB OSITY

Related Programming Command

SETC

MAIN
COIL DR

Softkey that displays the output produced by the main-coil driver on the A7 analog interface assembly. This is a service diagnostic function and is for service use only.

Key Path

(CALIBRATE) More 1 of 3 More 2 of 3 Service Diag More 1 MAIN COIL DR

Related Programming Command

none

MAIN
SPAN

Softkey that displays the main-coil-span signal, MC_SPAN, from the span dividers on the A7 analog interface assembly. This is a service diagnostic function and is for service use only.

Key Path

(CALIBRATE) More 1 of 3 More 2 of 3 Service Diag More 1 More 2 MAIN SPAN

Related Programming Command

none

MAN TRK
ADJUST

Softkey that allows the user to adjust the frequency of the tracking-generator oscillator manually using the step keys or knob. The tracking adjust is tuned to maximize the amplitude of the trace.

Tracking error occurs when the output frequency of the tracking generator is not exactly matched to the input frequency of the instrument. The resulting mixing product from the instrument input mixer is not at the center of the IF bandwidth. Any tracking errors may be compensated for by manually adjusting the oscillator of the tracking generator, or by performing an automatic tracking routine, which is initiated by pressing TRACKING PEAK.

Key Path

(TRACK GEN) MAN TRK ADJUST

Related Programming Command

SRCTK

MARGIN 1
ON OFF

Softkey that sets the amplitude (in negative decibels) and display state for limit margin 1. The limit margin is a fixed amplitude relative to the limit line.

Key Path

(DISPLAY) More 1 of 2 Limit Lines Limit 1 MARGIN 1 ON OFF

(SETUP) More 1 of 3 Limit Lines Limit 1 MARGIN 1 ON OFF

Related Programming Command

LIMIMARGAMP, LIMIMARGSTA

MARGIN 2
ON OFF

Softkey that sets the amplitude (in negative decibels) and display state for limit margin 2. The limit margin is a fixed amplitude relative to the limit line.

Key Path

(DISPLAY) More 1 of 2 Limit Lines Limit 2 MARGIN 2 ON OFF

(SETUP) More 1 of 3 Limit Lines Limit 2 MARGIN 2 ON OFF

Related Programming Command

LIMIMARGAMP, LIMIMARGSTA

MARK ALL
DUPLICAT

Softkey that marks all identical signals in the signal list.

Key Path

(TEST) More 1 of 3 EDIT LIST Signal Marking Selectv Mark MARK ALL DUPLICAT

Related Programming Command

SIGMARK

**MARK ALL
SIGNALS**

Softkey that marks all signals in the signal list.

Key Path

(TEST) More 1 of 3 EDIT LIST Signal Marking MARK ALL SIGNALS

Related Programming Command

SIGMARK

**MARK LWR
DUPLICAT**

Softkey that marks all duplicate signals in the list that are lower in peak amplitude.

Key Path

(TEST) More 1 of 3 EDIT LIST Signal Marking Selectv Mark MARK LWR DUPLICAT

Related Programming Command

SIGMARK

**MARK
SIGNAL**

Softkey that marks the highlighted signal in the signal list.

Key Path

(TEST) More 1 of 3 EDIT LIST Signal Marking MARK SIGNAL

Related Programming Command

SIGMARK

**MARK TO
END**

Softkey that marks all signals, after the highlighted signal, to the end of the list.

Key Path

(TEST) More 1 of 3 EDIT LIST Signal Marking Selectv Mark MARK TO END

Related Programming Command

SIGMARK

MARKER

Softkey that activates a single marker at the center frequency on the active trace if an onscreen marker is not already displayed. If there is an onscreen marker, a frequency marker is enabled at the position of the first marker. Use the knob and data keys to position the marker. When a measurement point is selected with the marker, the frequency and the selected detectors (peak, quasi-peak, and average detectors) are displayed in the marker box.

Key Path

(TEST) More 1 of 3 More 2 of 3 MEAS STEPPED STOP MARKER

(TEST) More 1 of 3 More 2 of 3 MEAS STEPPED FREQ STEP MARKER

Related Programming Command

none

MARKER Δ

Softkey that activates a second marker at the position of the first marker. (If no marker is present, two markers appear at the center of the display.) The amplitude and frequency of the first marker is fixed, and the second marker is under your control. Annotation in the active function block and in the upper-right corner of the screen indicates the frequency and amplitude differences between the two markers. The display mode must not be changed between log and linear while using a delta marker.

Note

If there are already four markers when **MARKER Δ** is pressed, a nonactive marker disappears, the active marker becomes a reference marker, and the delta marker becomes the active marker.

Key Path

(MKR) MARKER Δ

(PEAK SEARCH) MARKER Δ

Related Programming Command

MKD

MARKER
ΔSPAN

Softkey that sets the start and stop frequencies to the values of the delta markers. The start and stop frequencies will not be set if the delta marker is off.

Key Path

MARKER
MKR -> ΔSPAN

Related Programming Command

MKSP

MARKER
->CF

Softkey that changes the instrument settings so that the frequency at the marker becomes the center frequency.

Key Path

MARKER
MKR -> ->CF

MARKER
PEAK SEARCH ->CF

Related Programming Command

MKCF

MARKER
->CF STEP

Softkey that changes the center-frequency step size to match the value of the active marker. Press (FREQUENCY) then CF STEP AUTO MAN to view the step size. If marker delta is active, the step size will be set to the frequency difference between the markers.

Key Path

MARKER
MKR -> ->CF STEP

Related Programming Command

MKSS

MARKER->
MINIMUM

Softkey that moves the active marker to the minimum detected amplitude value.

Key Path

MARKER->
(MKR ->) MINIMUM

Related Programming Command

MKMIN

MARKER
->PK-PK

Softkey that finds and displays the frequency and amplitude differences between the highest and lowest trace points.

Pressing MARKER ->PK-PK performs the routine similar to pressing the following keys: (PEAK SEARCH), MARKER Δ, and MARKER-> MINIMUM.

Key Path

More MARKER
(MKR ->) 1 of 2 ->PK-PK

Related Programming Command

MKPK

MARKER
->REF LVL

Softkey that changes the instrument settings so that the amplitude at the active marker becomes the reference level.

Key Path

MARKER
(MKR ->) ->REF LVL

Related Programming Command

MKRL

MARKER
->START

Softkey that changes the start frequency so that it is equal to the frequency of the active marker. This moves the active marker to the left edge of the display.

Key Path

More MARKER
MRK -> 1 of 2 ->START

Related Programming Command

none

MARKER
->STOP

Softkey that changes the stop frequency so that it is equal to the frequency of the active marker. This moves the active marker to the right edge of the display.

Key Path

More MARKER
MRK -> 1 of 2 ->STOP

Related Programming Command

MKSTOP

MARKER 1
ON OFF

Softkey that makes marker 1 the active marker. If there is more than one marker displayed on the display, marker 1 must be made active before it can be manipulated.

Key Path

MARKER 1
MKR ON OFF

Related Programming Command

MKACTV

MARKER 2
ON OFF

Softkey that makes marker 2 the active marker. If there is more than one marker displayed on the display, marker 2 must be made active before it can be manipulated.

Key Path

MARKER 2
MKR ON OFF

Related Programming Command

MKACTV

MARKER 3
ON OFF

Softkey that makes marker 3 the active marker. If there is more than one marker displayed on the display, marker 3 must be made active before it can be manipulated.

Key Path

MARKER 3
(MKR) ON OFF

Related Programming Command

MKACTV

MARKER 4
ON OFF

Softkey that makes marker 4 the active marker. If there is more than one marker displayed on the display, marker 4 must be made active before it can be manipulated.

Key Path

MARKER 4
(MKR) ON OFF

Related Programming Command

MKACTV

MARKER
ALL OFF

Softkey that turns off all of the markers, including markers used for marker track and demodulation. Marker annotation is also removed.

Key Path

More MARKER
(MKR) 1 of 2 ALL OFF

Related Programming Command

MKOFF

MARKER AMPTD

Softkey that keeps the active marker at the requested amplitude on the screen. Once activated, the marker remains at the amplitude selected by the step keys, knob, or data keys, even if the signal frequency is changed. The marker will be placed on the signal furthest left at that amplitude. If no signal exists at that amplitude, it will be placed above the highest signal amplitude (or below the lowest trace element if it is below all trace elements). When marker delta is active in addition to marker amplitude, the behavior of the active marker is useful for measuring signal bandwidths. For example, place a marker 20 dB below the peak of a signal, press **MARKER Δ**, **MARKER AMPTD**. The marker readout shows the 20 dB bandwidth.

Key Path

MARKER
(MKR) **AMPTD**

Related Programming Command

MKA, MKTYPE

MARKER FUNCTION

Hardkey that accesses the marker function softkeys. These softkeys can be used to access the marker table and to turn on marker functions for tracking the signal and counting its frequency. Noise markers and the marker pause are also accessed under **MARKER FUNCTION**.

Related Programming Command

none

MARKER NORMAL

Softkey that activates a single frequency marker at the center frequency on the active trace if an onscreen marker is not already displayed. If there is an onscreen marker before the **MARKER NORMAL** function is enabled, a frequency marker is enabled at the position of the first marker. Use the data controls to position the marker. Annotation in the active function block and in the upper-right corner indicates the frequency and amplitude of the marker. The marker stays on the trace at the horizontal screen position where it was left unless **MK TRACK ON OFF**, **MARKER AMPTD**, or a “marker to” softkey function (such as **MARKER ->CF**, **MARKER ->REF LVL**, **MARKER ->CF STEP**, **MARKER Δ ->SPAN**, or **MARKER-> MINIMUM**) is selected. Pressing **MARKER NORMAL** turns off the marker-delta function.

Key Path

MARKER
(MKR) NORMAL

Related Programming Command

MKN

MARKERS

Softkey that activates the markers portion of the display screen for color editing.

Key Path

Display Adjust Edit More More
(DISPLAY) Config Colors Colors 1 of 3 2 of 3
MARKERS

Related Programming Command

SETC

MARKER TUNE SPN

Softkey that modifies the behavior of the marker positioning functionality of the instrument when accessed through the data keys, knob, or stepkeys.

When **MARKER TUNE SPN** is activated and TUNE is underlined:

- Data key input, positions frequency and time markers at the specified numeric frequency input, tuning the instrument to the specified frequency if necessary. Numeric key-pad input terminators are “Hz, kHz, MHz, or GHz”.
- Knob input, repositions the marker position as a function of frequency, tuning the instrument to its specified frequency if the knob input places the marker position beyond the limits of the current span.
- Step-key input:
 - Zero-span, steps the marker to the edge of the display and retunes the instrument on succeeding step-key presses.
 - Non-zero span, positions the marker at the next peak left (⏮) or next peak right (⏭) by one half of the intermediate frequency bandwidth. If no signals exist, the marker is positioned at the left edge (⏮) or the right edge (⏭) of the display. If the marker is already at the edge of the display, subsequent steps retune the instrument by a step equal to the size of the current span.

Key Path

MARKER
(TEST) TUNE SPN

Related Programming Command

RCVRMRKR

MAX
HOLD A

Softkey that maintains the maximum level for each trace point of trace A and updates each trace point if a new maximum level is detected in successive sweeps.

Key Path

MAX
(TRACE) HOLD A

Related Programming Command

MXMH

MAX
HOLD B

Softkey that maintains the maximum level for each trace point of trace B and updates each trace point if a new maximum level is detected in successive sweeps.

Key Path

MAX
(TRACE) HOLD B

Related Programming Command

MXMH

MAX MXR
LVL

Softkey that lets you change the maximum input mixer level in 10 dB steps from -10 dBm to -100 dBm. The mixer level is equal to the reference level minus the attenuator setting. As the reference level changes, the input attenuator setting is changed to keep the power levels less than the selected level at the input mixer. Pressing (PRESET) resets the maximum input mixer level to -10 dBm.

Key Path

More MAX MXR
(AMPLITUDE) 1 of 3 LVL

Related Programming Command

ML

MEAS
SNG CONT

Softkey that sets the stepped measurements for either single or continuous sweep mode.

Key Path

| | | | | |
|--------|--------|--------|---------|----------|
| | More | More | MEAS | MEAS |
| (TEST) | 1 of 3 | 2 of 3 | STEPPED | SNG CONT |

| | | | | |
|--------|--------|--------|---------|---------------|
| | More | More | MEAS | MEAS |
| (TEST) | 1 of 3 | 2 of 3 | STEPPED | STOP SNG CONT |

| | | | | | |
|--------|--------|--------|---------|-------|----------|
| | More | More | MEAS | FREQ | MEAS |
| (TEST) | 1 of 3 | 2 of 3 | STEPPED | STEPA | SNG CONT |

Related Programming Command

none

MEAS
STEPPED

Softkey that initiates a stepped measurement. The stepped measurement is taken between the specified start and stop frequencies in conjunction with the selected step size (FREQ STEP), step type (STEP LOG LIN), and step mode (MEAS SNG CONT).

Key Path

| | | | |
|--------|--------|--------|---------|
| | More | More | MEAS |
| (TEST) | 1 of 3 | 2 of 3 | STEPPED |

Related Programming Command

none

MEAS/USER

Hardkey that switches between the User Menu and the menu containing FFT MEAS, 3 dB POINTS, 6 dB POINTS, 99% PWR PW, % AM, 3rd ORD MEAS, DELTA MEAS, and PK-PK MEAS. If no keys have been defined in the user menu, No User Menu is displayed.

MEASURE
AT MKR

Softkey that makes a measurement, using specified detectors, with the marker position as the measurement frequency.

Note

When the selected bandwidth is a non-CISPR bandwidth the message, Non-CISPR bandwidth being used, press CONTINUE to resume or press USE CISPR to change, is displayed.

Key Path

MEASURE
(TEST) AT MKR

Related Programming Command

MEASSIG

Measure
Detector

Softkey that accesses a menu to select automatic measuring or the measurement time of the specified detectors.

Key Path

More Inst Measure
(SETUP) 1 of 3 Setup Detector

Related Programming Command

none

MEM
LOCKED

Softkey available only when SAV LOCK ON OFF is on.

Softkey that locks all the current internal state and trace registers against further data storage. With the state and trace memory locked, the STATE -> INTRNL and Trace -> Intrnl softkey functions are no longer accessible; MEM LOCKED is displayed instead. Pressing DEFAULT CONFIG or (PRESET) sets SAV LOCK ON OFF to OFF.

Note

When SAVE LOCK ON OFF is set to ON, none of the state registers can be overwritten, including state register nine. The instrument automatically updates state register nine with the last state unless the save lock function is on.

Key Path

Save MEM
(SAVE) Internal LOCKED

Related Programming Command

PSTATE

MIN
HOLD C

Softkey that updates trace C with the minimum level detected.

Key Path

(TRACE) MIN
HOLD C

Related Programming Command

MINH

MIXER
BIAS DAC

For an HP 8546A/HP 85462A only.

Softkey that displays the output of the mixer-bias DAC from the first-converter driver on the A7 analog interface assembly. This is a service diagnostic function and is for service use only.

Key Path

(CALIBRATE) More 1 of 3 More 2 of 3 Service Diag More 1 ... More 5
MIXER
BIAS DAC

Related Programming Command

none

MK COUNT
ON OFF

Softkey that turns on the marker counter when ON is underlined. If no marker is active before MK COUNT ON OFF is pressed, a marker is activated at center screen. Press MK COUNT ON OFF (so that OFF is underlined), to turn the marker counter off. Press CNT RES AUTO MAN to change the marker counter resolution to an uncoupled value.

An (*) may appear in the upper right of the display along with the message Marker Count. The ratio of the intermediate frequency bandwidth to span must be greater than 0.01 for the marker count function to work properly. Reduce Span appears on screen if the bandwidth to span ratio is less than 0.01. The function will count the largest signal in a 300 Hz bandwidth even if a narrower bandwidth setting is used.

Key Path

(MARKER FUNCTION) MK COUNT
ON OFF

Related Programming Command

MKFC

MK NOISE
ON OFF

Softkey that reads out the average noise level, referenced to a 1 Hz noise power bandwidth, at the marker position. If no marker is present, a marker appears at the center of the screen. The root-mean-square noise level, normalized to a 1 Hz noise power bandwidth, is read out. The sample detector is activated.

Key Path

(MARKER FUNCTION) MK NOISE
ON OFF

Related Programming Command

MKNOISE

MK PAUSE
ON OFF

Softkey that stops the instrument sweep at the marker position for the duration of the dwell time. The dwell time can be set from 2 milliseconds to 100 seconds.

Key Path

(MARKER FUNCTION) MK PAUSE
ON OFF

Related Programming Command

MKPAUSE

(MKR)

Hardkey that accesses the marker control softkeys which select the type and number of markers and turn them on and off. Markers are diamond-shaped characters that identify points of traces and allow the traces to be manipulated and controlled on the screen. During manual operation, four markers may appear on the display simultaneously; only one can be controlled at a time. The marker that is controlled is called the “active” marker. Pressing (MKR) activates the MARKER NORMAL softkey.

Related Programming Command

none

MKR ->

Hardkey that accesses a menu of marker-to-functions such as,

- **MARKER -> CF**
- **MARKER -> REF LVL**
- **MARKER -> CF STEP**
- **MARKER -> MINIMUM**
- **MARKER -> START**
- **MARKER -> STOP**
- **MARKER -> PK-PK**
- **MARKER Δ SPAN**

Related Programming Command

none

**MK READ
F T I P**

Softkey that selects the marker readout to be displayed in signal frequency, sweep time, the inverse of the sweep time, or the period which is the inverse of the frequency. When the instrument is in zero span the frequency type readout cannot be selected.

Key Path

More **MK READ**
MKR 1 of 2 **F T I P**

Related Programming Command

MKREAD

**MK TRACE
AUTO ABC**

Softkey that assigns a marker to a trace. Pressing **MK TRACE AUTO ABC** will activate a marker on trace A if there are no markers turned on. If a marker is currently active, press **MK TRACE AUTO ABC** until A, B, or C are underlined. The active marker will be moved to the selected trace.

Selecting the auto mode will move the marker to the trace that is automatically selected. The selection order is to first look for a trace in the clear-write mode, in trace A, then trace B, then trace C. If no traces are currently being written, it will select a trace in the view-store mode, again in the order of trace A, B, then C.

Key Path

More MK TRACE
(MKR) 1 of 2 AUTO ABC

Related Programming Command

MKTRACE

MK TRACK
ON OFF

Softkey that moves the signal that is nearest to the active marker to the center of the screen and keeps the signal there. MKR-TRK or CNTR-TRK appears in the upper-right corner of the display. An (*) may appear in the upper-right corner of the display while the instrument is verifying that it has the correct signal.

Pressing MK TRACK ON OFF, (PRESET), MARKER NORMAL, or MARKER ALL OFF turns off the marker-track function.

When marker track is on and the span is reduced, an automatic zoom is performed: the span is reduced in steps so that the signal remains at the center of the screen. If the span is zero, marker track cannot be activated.

Key Path

MK TRACK
(MARKER FUNCTION) ON OFF

Related Programming Command

MKTRACK

MNOPQR

Softkey that accesses a menu for selecting screen title or prefix characters M through R.

Key Access

(CAL), (CONFIG), (DISPLAY), (RECALL), (SAVE), or (SETUP)

Related Programming Command

none

MODE

Hardkey that accesses the menu for selecting **EMI RECEIVER** or **SIGNAL ANALYSIS** modes of operation.

Related Programming Command

none

**MONO-
CHROME**

Softkey that sets the screen display to green monochrome. The monochrome display is uses different shades of green for each green value. This is especially useful for driving external monochrome monitors from the green video output.

Key Path

DISPLAY Display Adjust Special MONO-
Config Color Colors CHROME

Related Programming Command

SETC

**NEW
EDIT**

Softkey that starts the DLP editor function, clearing the DLP editor memory to create a new item in the 2500 byte DLP editor memory. The item will not be in the user memory of the instrument until it is processed by the **SAVE EDIT** softkey. The DLP editor memory buffer remains intact when the instrument is preset and when it is powered off.

Key Path

RECALL Recall Catalog NEW
Internal Internal ... * Editor EDIT
SAVE Save Catalog NEW
Internal Internal ... * Editor EDIT

* Any of the following can be used to complete the key path:
CATALOG ALL , **CATALOG VARIABLES** , or **CATALOG PREFIX** .

Related Programming Command

none

NEXT

Hardkey that selects the upper or lower window as the active window. When the windows display mode is activated, there will be two windows displayed on the screen. Only one of the windows is active (the active window will have a highlighted line around the graticule). Pressing **NEXT** consecutively, will toggle between the two windows.

Related Programming Command

WINNEXT

NEXT PAGE

Softkey that displays the next page of the instrument setup. For example, if you are currently viewing page 2 of the instrument setup pressing **NEXT PAGE** will display page 3 of the instrument setup.

Key Path

More **SHOW** **NEXT**
SETUP 1 of 3 **SETUP** **PAGE**

Related Programming Command

none

NEXT PEAK

Softkey that moves the active marker to the next signal peak of higher amplitude. The signal peak must exceed the threshold value. (Also see the **PEAK EXCURSN** and **THRESHLD ON OFF** softkey descriptions.)

Key Path

NEXT
PEAK SEARCH **PEAK**

Related Programming Command

MKPK

NEXT PK LEFT

Softkey that moves the marker to the next peak left of the current marker. The signal peak must exceed the threshold value. If there is no peak to the left, the marker will not move. (Also see the **PEAK EXCURSN** and **THRESHLD ON OFF** softkey descriptions.)

Key Path

NEXT PK
PEAK SEARCH **LEFT**

Related Programming Command

MKPK

NEXT PK
RIGHT

Softkey that moves the marker to the next peak right of the current marker. The signal peak must exceed the threshold value. If there is no peak to the right, the marker will not move. (Also see the PEAK EXCURSN and THRESHLD ON OFF softkey descriptions.)

Key Path

PEAK SEARCH NEXT PK
RIGHT

Related Programming Command

MKPK

NO
CONVERSN

Softkey that specifies that no conversion units are used for the antenna amplitude-correction factors.

Key Path

SETUP More Correctn Antenna EDIT More
1 of 3 Factors Factors ANTENNA 1 of 2
Antenna NO
Units CONVERSN

Related Programming Command

XUNITS

No User
Menus

Softkey that is displayed if no user menus have been defined by the user.

Key Path

MEAS/USER User No User
Menus Menus

Related Programming Command

none

NORMLIZE
ON OFF

Softkey that subtracts trace B from trace A and adds the result to the display line. The result is displayed in trace A. The trace data is normalized with respect to the display line even if the value of the display line is changed. This function is executed on all subsequent sweeps until it is turned off. A minus sign (–) appears between the trace A status and the trace B status in the screen annotation while the function is active. To turn off the normalize function, press **NORMLIZE ON OFF** so that OFF is underlined.

The normalize function is useful for applying correction data to a trace. For example, store a measurement sweep of the response of a system in trace B. Trace A can be used to measure the response of the system after a device is added. Set **NORMLIZE ON OFF** to ON to subtract the system response from the response of the device under test, to characterize the response of a device under test.

Key Path

More **NORMALIZE**
TRACE 1 of 3 **ON OFF**

Related Programming Command

AMBPL

NORMLIZE
POSITION

Softkey that displays the display line and makes the display line function active. The trace data is normalized with respect to the display line even if the value of the display line is changed.

Key Path

More **NORMALIZE**
TRACE 1 of 3 **POSITION**

Related Programming Command

none

ON/OFF

Hardkey that turns the AM or FM demodulation on and off. If the instrument is in a nonzero span, a marker is placed at center screen if an onscreen marker is not already present. The marker pause is changed to equal the current dwell time value. Demodulation takes place on any signal that is indicated by the marker position during the marker pause. There is no change to the display during marker pause, but the demodulation signal is present on the AUX VIDEO OUT. Also see the **SPEAKER ON OFF** softkey description.

Pressing **ON/OFF** selects the sample peak detector for AM demodulation, the FMV detectors for FM demodulation. If the instrument is in zero span, demodulation is done continuously, with or without an onscreen marker.

Related Programming Command

DEMODO

**OPTICAL
FILTER**

Softkey that selects a vision enhanced mode where an optical filter is used to accommodate the use of protective goggles when viewing lasers.

Key Path

(DISPLAY) Display Config Adjust Color Special Colors OPTICAL FILTER

Related Programming Command

SETC

**OTHER
-> DISK**

Softkey that saves *other* two-port amplitude-correction factors to a disk. To save *other* amplitude-correction factors press, **OTHER -> DISK**. REGISTER # and PREFIX= are displayed on the screen. Use the data keys to enter the desired register number then press **(ENTER)**. The message Saving to :FILENAME is displayed. The *other* two-port amplitude-correction data has now been saved to a disk.

Key Path

(SAVE) Save Disk More 1 of 2 OTHER -> DISK

Related Programming Command

none

**Other
Factors**

Softkey that accesses a menu to turn on, recall, edit, or save *other* amplitude-correction factors for any two-port device, excluding antenna and cable factors, placed between the antenna and the instrument.

Key Path

(SETUP) More 1 of 3 Correctn Factors Other Factors

Related Programming Command

AMPCOR

OTHER
ON OFF

Softkey that turns on or off *other* two-port amplitude-correction factors, excluding antenna and cable factors, placed between the antenna and the instrument.

Key Path

(SETUP) More Correctn Other OTHER
1 of 3 Factors Factors ON OFF

Related Programming Command

AMPCOR

(OUTPUT)

Hardkey that accesses a menu to output reports to a plotter or a printer, or send a copy of the current display to the printer.

Related Programming Command

none

OUTPUT
REPORT

Softkey that outputs a report to the specified plotter or printer.

Key Path

(OUTPUT) OUTPUT
REPORT

Related Programming Command

none

OVL
ON OFF

Softkey that enables or disables RF and IF overload status.

Key Path

(AMPLITUDE) OVL
ON OFF

(SETUP) More Inst OVL
1 of 3 Setup ON OFF

Related Programming Command

OVL

PAINTJET

Softkey that specifies an HP PaintJet as the printer connected to the output port.

Key Path

Print Printer More
(CONFIG) Config Type 1 of 3 PAINTJET

Related Programming Command

PRNTTYPE

PALETTE BARS

Softkey that replaces the standard display screen with palette bars. This is one of 18 test patterns that can be used for display-troubleshooting and screen-alignment procedures.

Key Path

Display Test More PALETTE
(DISPLAY) Config Patterns 1 of 4 BARS

Related Programming Command

none

PEAK EXCURSN

Softkey that sets the minimum amplitude variation of signals that the marker can identify as a peak. If a value of 10 dB is selected, the marker moves only to peaks that rise and fall more than 10 dB above the threshold line (or the noise floor of the display). Pressing (PRESET) or turning on power resets the excursion to 6 dB, and the threshold to 70 dB below the reference level.

Note

When a peak has a lump on its skirt that is the peak-excursion value above the threshold, the lump is considered a peak in its own right only if it has a peak excursion drop on both sides. Two peaks that are so close that only a valley divides them are not differentiated if the valley is not the peak-excursion value deep.

When the peak excursion value is less than 6 dB, the marker-peaking functions may not recognize signals less than 6 dB above the noise floor. To correct this, when measuring signals near the noise floor, the excursion value can be reduced even further. To prevent the marker from identifying noise as signals, reduce the noise floor variance to a value less than the peak-excursion value by reducing the average video bandwidth or by using video averaging.

Key Path

More PEAK
(PEAK SEARCH) 1 of 2 EXCURSN

PEAK
(CTRL) EXCURSN

Related Programming Command

MKPX

Peak Menu

Softkey that accesses the softkeys that are available when (PEAK SEARCH) is pressed (see the key description for (PEAK SEARCH) below). Pressing Peak Menu instead of (PEAK SEARCH) allows you to use the peak-search functions without initiating a new peak search.

Key Path

More Peak
(MKR ->) 1 of 2 Menu

Related Programming Command

none

(PEAK SEARCH)

Hardkey that automatically places a marker on the highest amplitude of a trace, and displays the amplitude and frequency of the marker. It also accesses the menus of marker peak functions.

Related Programming Command

MKPK

PK DWELL TIME

Softkey that sets the measurement time when the peak detector is measured. This key is used in conjunction with MEASURE AT MKR, RE-measure, AUTO-MEASURE, and MEAS STEPPED.

Key Path

More Inst Measure PK DWELL
(SETUP) 1 of 3 Setup Detector TIME

Related Programming Command

MEASTIMEPK

PK-PK MEAS

Softkey that initiates an automatic measurement of the frequency and amplitude differences of the highest and lowest signals displayed on the screen. Pressing PK-PK MEAS performs a routine that is similar to MARKER Δ and then moving the second marker to the lowest detected signal.

Key Path

More PK-PK
MEAS/USER 1 of 2 MEAS

Related Programming Command

none

Plot Config

Softkey that accesses the menu used to address the plotter and to select plotter options. See the COPY key for more information.

Key Path

Plot
CONFIG Config

Related Programming Command

none

PLOTTER ADDRESS

Softkey that changes the HP-IB address of the plotter. The plotter address is set to 5 when DEFAULT CONFIG is pressed.

Key Path

Plot PLOTTER
CONFIG Config ADDRESS

Related Programming Command

none

PLT MENU
ON OFF

Softkey that allows the softkey labels to be plotted along with the display. This function operates when the **(COPY)** key is used in a plot configuration. The plot menu function is set to on when **DEFAULT CONFIG** is pressed.

Key Path

Plot PLT MENU
(CONFIG) Config ON OFF

Related Programming Command

none

PLTS/PG
1 2 4

Softkey that allows you to choose a full-page, half-page, or quarter-page plot. Press **PLTS/PG 1 2 4** to underline the number of plots per page desired. If two or four plots per page are chosen, a softkey function is displayed that allows you to select the location of the plotter output on the paper. If two plots per page are selected, **[] LOC _ _** is displayed. If four plots per page are selected, **[] _LOC _ _** is displayed. Press the softkey until the rectangular marker is in the desired section of the softkey label. The upper and lower sections of the softkey label graphically represent the position of the page where the plotter output will be located.

Note

The HP 7470A plotter does not support two plots per page output, you can select one or four plots per page.

Key Path

Plot PLTS/PG
(CONFIG) Config 1 2 4

Related Programming Command

none

POINT

Softkey that specifies a limit value for one coordinate point, so that a point segment specifies a limit value for a single frequency. (For signal analysis mode only, the point segment can specify a limit value for time also.) The point segment type is generally used as the last segment in the limit-line table. However, if the last segment in the table is not of the point segment type, an implicit point is automatically added at the right-hand side of the screen.

Key Path

Receiver Mode

| | | | | | | |
|-----------|--------|-------|-------|-------|--------|-------|
| | More | Limit | | EDIT | Select | |
| (DISPLAY) | 1 of 2 | Lines | ... * | LIMIT | Type | POINT |

| | | | | | | |
|---------|--------|-------|-------|-------|--------|-------|
| | More | Limit | | EDIT | Select | |
| (SETUP) | 1 of 3 | Lines | ... * | LIMIT | Type | POINT |

Signal Analysis Mode

| | | | | | | |
|-----------|--------|-------|-------|-------|--------|-------|
| | More | Limit | Edit | | Select | |
| (DISPLAY) | 1 of 2 | Lines | Limit | ... † | Type | POINT |

| | | | | | | |
|---------|--------|-------|-------|-------|--------|-------|
| | More | Limit | Edit | | Select | |
| (SETUP) | 1 of 3 | Lines | Limit | ... † | Type | POINT |

* Either **Limit 1** or **Limit 2** can be used to complete the key path.

† Any of the following can be used to complete the key path:

EDIT UPPER, **EDIT LOWER**, **EDIT UP/LOW**, or **EDIT MID/DELT**.

Related Programming Command

none

POWER ON IP LAST

Softkey that determines the state of the instrument when the instrument is powered on. If the POWER ON function is set to IP, the state of the instrument is the same as it is after **(PRESET)** is pressed, when the instrument is powered on. If the POWER ON function is set to LAST, then the state that the instrument was left in when it was powered off is recalled.

The setting (IP or LAST) of the POWER ON function is not changed by pressing **(PRESET)**. Use the **POWER ON IP LAST** softkey function to change the setting of the instrument state which is recalled at power on. Limit lines are not recalled when the instrument is powered up.

Note

If you have a downloadable program or “personality” installed in internal memory, the following changes apply to the operation of the POWER ON function: When using a downloadable program or personality, the last state of the personality is not recalled. We recommend that if you are using a downloadable program or personality, you set **POWER ON IP LAST** to IP. If **POWER ON IP LAST** is set to LAST, you must press **(PRESET)** whenever you power on the instrument.

Key Path

| | | | |
|----------|--------|--------|----------|
| | More | More | POWER ON |
| (CONFIG) | 1 of 3 | 2 of 3 | IP LAST |

| | | | |
|---------|--------|--------|----------|
| | More | More | POWER ON |
| (SETUP) | 1 of 3 | 2 of 3 | IP LAST |

Related Programming Command

POWERON

PREAMP

Hardkey that switches the system preamplifier in and out of the input path. **PREAMP** acts as an on or off toggle switch. This key performs the same function as the **PREAMP ON OFF** softkey.

**PREAMP
ON OFF**

Softkey that switches the system preamplifier in and out of the input path.

When the preamplifier is on:

The receiver RF section with RF filter section adds 12 dB of gain to the path of either INPUT 1 (9 kHz to 50 MHz) or INPUT 2 (20 MHz to 2.9 GHz).

The EMI receiver and standalone receiver RF section adds 27 dB of gain to either the path of INPUT 2 (1 GHz to 6.5 GHz) or the bypass path of INPUT 2.

Note

INPUT 2 (1 GHz to 6.5 GHz) is available only for the HP 8546A EMI receiver or the HP 85462A receiver RF section.

When the RF filter section is present in the system, the following input path selections set the preamplifier as follows:

- INPUT 1 (9 kHz to 50 MHz): PREAMP OFF
- INPUT 2 (20 MHz to 2.9 GHz): PREAMP OFF
- INPUT 2 (1 GHz to 6.5 GHz): PREAMP ON
- INPUT 2 bypass: PREAMP OFF

Key Path

| | | | |
|---------|--------|-------|--------|
| | More | Inst | PREAMP |
| (SETUP) | 1 of 3 | Setup | ON OFF |

Related Programming Command

PREAMP

PRESEL DAC

For an HP 8546A/HP 85462A only.

Softkey that peaks the YTF preselector by allowing the user to manually adjust the YTF fine-tune DAC. This is a service diagnostic function and is for service use only.

Key Path

CALIBRATE More 1 of 3 More 2 of 3 Service Diag More 1 ... More 5
PRESEL
DAC

Related Programming Command

none

PRESEL DEFAULT

For an HP 8546A/HP 85462A only.

Softkey that enables default preselector data to allow maximum frequency response without peaking the preselector. The CAL YTF routine should be performed before pressing **PRESEL DEFAULT**.

Key Path

AMPLITUDE More 1 of 3 PRESEL DEFAULT

Related Programming Command

none

PRESEL PEAK

For an HP 8546A/HP 85462A only.

Softkey that optimally centers the preselector on a given signal for the most accurate measurement of amplitude. The maximum response found for the frequency at the marker determines the future adjustment values that will be provided to the preselector.

Key Path

AMPLITUDE PRESEL
PEAK

Related Programming Command

PP

PRESET

Hardkey that provides a convenient starting point for making most measurements. Pressing **PRESET** displays softkeys used for accessing the operating modes available for your instrument. See Table 4-6 and Table 4-7 for the conditions established by pressing **PRESET**.

The instrument preset function performs a processor test, but does not affect CAL data. Pressing **PRESET** clears both the input and output buffers, but does not clear trace B. The amplitude values of trace C are set to the reference level. Amplitude-correction factors are turned off. Limit-line testing is turned off, but the limit-line tables remain in internal memory. The status byte is set to 0. Instrument preset affects all operating modes. (See the key description for **MODE** for more information about other operating modes.)

Note

Turning the instrument on performs an instrument preset. Turning on the instrument also fetches CAL data; completes a processor test; clears trace B, trace C, and both the input and output buffers; turns off amplitude correction factors; turns off limit-line testing; and sets the status byte to 0. The last state of the instrument (before it was switched off) is recalled, unless instrument preset has been set by the power on function.

**Table 4-6.
Preset Conditions for Receiver Mode of Operation**

| | |
|----------------------------------|--|
| A – B -> A | off |
| Amplitude correction factors | off |
| Amplitude units | default values |
| Annotation and graticule display | on |
| Attenuation | 10 dB (auto-coupled) |
| Average bandwidth | 1 MHz (auto-coupled) |
| AV/IFBW ratio | 0.3 |
| Center frequency | 600 MHz |
| CF step size | 100 MHz |
| Coupled functions | all set to AUTO |
| Coupling | AC |
| Detector | positive peak |
| Display line level | 2.5 graticule divisions below reference level, display off |
| Frequency offset | 0 Hz |
| Intermediate frequency bandwidth | 120 kHz (auto-coupled) |
| Limit-line testing | off |
| Log scale | 10 dB/division |
| Marker counter | off |
| Marker counter resolution | auto-coupled |
| Markers | off |
| Mixer level | -10 dBm |
| Operating mode | receiver |
| Preselector peak | reset |
| Reference level | 92 dB μ V in power-on units |
| Reference level offset | 0 dB |
| Reference level position | top (8th) graticule |
| Span | 6.5 GHz |
| SRQ mask | octal 50 |
| Start Frequency | 200 MHz |
| Stop Frequency | 1 GHz. |
| State registers 1–8 | unaffected |
| Sweep | continuous |
| Threshold level | one graticule above baseline, display off |
| Title | cleared |
| Trace A | clear-write |
| Trace B | store-blank |
| Trace C | store-blank, at reference level |
| Trace registers | unaffected |
| Trigger | free run |
| Video averaging | off |

Table 4-7.
Preset Conditions for Signal Analysis Mode of Operation

| | |
|----------------------------------|--|
| A – B -> A | off |
| Amplitude correction factors | off |
| Amplitude units | default values |
| Annotation and graticule display | on |
| Attenuation | 10 dB (auto-coupled) |
| Average bandwidth | 1 MHz (auto-coupled) |
| AV/IFBW ratio | 0.3 |
| Center frequency | 3.25 GHz |
| CF step size | 100 MHz |
| Coupled functions | all set to AUTO |
| Coupling | AC |
| Detector | positive peak |
| Display line level | 2.5 graticule divisions below reference level, display off |
| Frequency offset | 0 Hz |
| Limit-line testing | off |
| LIMIHI and LIMILO | cleared |
| Log scale | 10 dB/division |
| Marker counter | off |
| Marker counter resolution | auto-coupled |
| Markers | off |
| Mixer level | -10 dBm |
| Operating mode | signal analysis |
| Preselector peak | reset |
| Reference level | 0 dB in power-on units |
| Reference level offset | 0 dB |
| Reference level position | top (Sth) graticule |
| Resolution bandwidth | 3 MHz (auto coupled) |
| Span | 800 MHz GHz |
| SRQ mask | octal 50 |
| Start Frequency | 0 Hz |
| Stop Frequency | 6.5 GHz. |
| State registers 1–8 | unaffected |
| Sweep | continuous |
| Threshold level | one graticule above baseline, display off |
| Title | cleared |
| Trace A | clear-write |
| Trace B | store-blank |
| Trace C | store-blank, at reference level |
| Trace registers | unaffected |
| Trigger | free run |
| Video averaging | off |
| Video bandwidth | 120 kHz |

Related Programming Command

IP

PRESET RECEIVER

Softkey that allows the receiver mode only to be preset. Table 4-8 lists the conditions affected by the preset receiver function. Other operating modes will not be affected. See the description of the **(MODE)** key.

Table 4-8. Preset Receiver Conditions

| | |
|----------------------------|---------------------------------|
| A – B -> A | off |
| Annotation and graticule | on |
| Attenuation | coupled |
| Average video bandwidth | 300 kHz (coupled) |
| AV/IFBW ratio | 0.3 |
| Center frequency | 1.46 GHz |
| Center frequency step size | 100 MHz |
| Coupled functions | all set to AUTO |
| Coupling | AC |
| Detector | positive peak |
| Display line | off |
| Frequency offset | 0 Hz |
| Harmonic lock | off |
| IF Bandwidth | 120 kHz (coupled) |
| Limit-line testing | off |
| Marker counter | off |
| Marker counter resolution | 6 kHz (auto-coupled) |
| Markers | off |
| Reference level | 92 dB μ V in power-on units |
| Reference level offset | - 15 dBm |
| Reference level position | top (8th graticule) |
| Scale | log 10dB/div |
| Span | 2.88 MHz |
| Start Frequency | 20 MHz |
| Stop Frequency | 2.9 GHz |
| State registers 1–8 | unaffected |
| Sweep | continuous |
| Sweep time | 2.70 s (auto-coupled) |
| Threshold | off |
| Trace A | clear write |
| Trace B | store-blank |
| Trace C | store-blank |
| Trace math | cleared |
| Trace registers | unaffected |
| Trigger | free |
| Video averaging | off |

Key Path

MODE PRESET RECEIVER, *when the instrument mode of operation is receiver and the **MODE** hardkey is pressed twice.*

Related Programming Command

none

PRESET SPECTRUM

Softkey that allows the signal analysis mode only to be preset. Table 4-9 lists the conditions affected by the preset spectrum function. Other operating modes will not be affected. See the description of the **MODE** key.

Table 4-9. Preset Spectrum Conditions

| | |
|----------------------------|-------------------------|
| A – B -> A | off |
| Annotation and graticule | on |
| Attenuation | 10 dB (coupled) |
| AV/IFBW ratio | 0.3 |
| Center frequency | 3.25 GHz |
| Center frequency step size | 100 MHz |
| Coupled functions | all set to AUTO |
| Coupling | AC |
| Detector | positive peak |
| Display line | off |
| Frequency offset | 0 Hz |
| Harmonic lock | off |
| Limit-line testing | off |
| Marker counter | off |
| Marker counter resolution | 2 kHz (auto-coupled) |
| Markers | off |
| Reference level | 0 dBm in power-on units |
| Reference level offset | 107 dB μ V |
| Reference level position | top (8th graticule) |
| Resolution bandwidth | 3 MHz (coupled) |
| Scale | log 10dB/div |
| Span | 6.5 GHz |
| Start Frequency | 0 Hz |
| Stop Frequency | 6.5 GHz |
| State registers 1–8 | unaffected |
| Sweep | continuous |
| Sweep time | 130 ms (auto-coupled) |
| Threshold | off |
| Trace A | clear write |
| Trace B | store-blank |
| Trace C | store-blank |
| Trace math | cleared |
| Trace registers | unaffected |
| Trigger | free |
| Video averaging | off |
| Video bandwidth | 1 MHz (coupled) |

Key Path

MODE PRESET SPECTRUM, when the instrument mode of operation is receiver and the **MODE** hardkey is pressed twice.

Related Programming Command

none

Print Config

Softkey that accesses a menu used to address the printer, select a black and white print or a color print (a color print requires either an HP PaintJet, HP DeskJet 500C, or HP DeskJet 550C printer), and reset the printer. See the **COPY** key for more information.

Key Path

CONFIG Print
Config

Related Programming Command

none

Print Options

Softkey that accesses a menu of print options such as; prints per page, low or high resolution, and color or black and white prints.

Key Path

CONFIG Print Print
Config Options

Related Programming Command

none

PRINTER ADDRESS

Softkey that changes the HP-IB address of the printer. The printer address is set to 1 by pressing **DEFAULT CONFIG**.

Key Path

CONFIG Print PRINTER
Config ADDRESS

Related Programming Command

PRNTADRS

PRINTER SETUP

Softkey that resets the printer, sets the printer to 60 lines per page, and skips line perforations. This function enables you to obtain up to two printouts per page. The printer paper should be at the top of the form before using this function.

Key Path

CONFIG Print PRINTER
Config SETUP

Related Programming Command

none

Printer
Type

Softkey that access a menu to specify what type of printer is connected to the output port.

Key Path

(CONFIG) Print Config Printer Type

Related Programming Command

PRNTTYPE

PROTECT
ON OFF

Softkey that selects whether files on a floppy disk can be silently overwritten in the event that a file by the same name already exists on the medium.

When ON is underlined, an error message will appear if you try to overwrite a file that already exists.

Key Path

(CONFIG) Disk Config PROTECT ON OFF

Related Programming Command

PROTECT

PRN/PG
1 2

Softkey that specifies the number of prints per page for printing.

Note

On some printers 1 print per page will generate a full page printout, other printers are unaffected by the prints per page setting.

Key Path

(CONFIG) Print Config Print Options PRN/PG 1 2

Related Programming Command

PRNTPPG

**PRT MENU
ON OFF**

Softkey that allows the softkey labels to be printed along with the display. This function operates when the **(COPY)** key is used in a print configuration. The print menu function is set to ON when **DEFAULT CONFIG** is pressed.

Key Path

(CONFIG) Print Config Print Options PRT MENU ON OFF

Related Programming Command

none

pTesla

Softkey that selects pTesla as the transducer conversion units for the antenna amplitude-correction factors.

Key Path

(SETUP) More 1 of 3 Correctn Factors Antenna Factors EDIT ANTENNA More 1 of 2
Antenna Units pTesla

Related Programming Command

XUNITS

**PURGE
LIMITS**

Signal analysis mode only.

Softkey that clears the current limit-line table from internal memory. Pressing **PURGE LIMITS** displays the message: If you are sure, press key again to purge data. Press **PURGE LIMITS** again if you wish to clear the current limit-line table. Press **SAVE LIMIT** to save the current limit-line table, and then press **PURGE LIMITS** to clear the current limit-line table.

Key Path

(DISPLAY) More 1 of 2 Limit Lines Edit Limit ... * More 1 of 2 PURGE LIMITS
(SETUP) More 1 of 3 Limit Lines Edit Limit ... * More 1 of 2 PURGE LIMITS

* Any of the following can be used to complete the key path:
EDIT UPPER, **EDIT LOWER**, **EDIT UP/LOW**, or **EDIT MID/DELT**.

Related Programming Command

LIMIDEL

PWR SWP
ON OFF

This softkey is only available when LIN is selected for the SWEEP LOG LIN softkey.

Softkey that activates (ON) or deactivates (OFF) the power-sweep function, which sweeps the output power of the tracking generator over the selected power-sweep range. The value of the power-sweep range is displayed in the active-function block when **PWR SWP ON OFF** is turned on. The available power-sweep range is a function of the source attenuator setting: For power sweeps, press **SRC ATN MAN AUTO** until (MAN) is underlined so the instrument source attenuator is manually set (decoupled).

For a given source attenuation setting, the maximum specified power-sweep range is shown in Table 4-10.

Table 4-10.

| Attenuator Setting | Power Sweep Range |
|--------------------|-------------------|
| 0 dB | -1 to -10 |
| 8 dB | -10.1 to -18 |
| 16 dB | -18.1 to -26 |
| 24 dB | -26.1 to -34 |
| 32 dB | -34.1 to -42 |
| 40 dB | -42.1 to -50 |
| 48 dB | -50.1 to -58 |
| 56 dB | -58.1 to -66 |

The output power of the tracking generator is swept with the sweep voltage of the instrument. The output power is always swept from the source power setting to a higher power setting (negative source power sweep values are not allowed). Refer to the calibration guide for your instrument for more information regarding source power and source attenuation relationships.

Power-sweep measurements are particularly useful in making gain compression measurements or output power versus frequency measurements.

Key Path

(TRACK GEN) **PWR SWP**
ON OFF

Related Programming Command

SRCPSWP

QP/AVG
10X OFF

This key is only active if either **QUASI-PEAK** or **AVERAGE** is used first.

Softkey that turns off the linear 10X gain stage in the quasi-peak and average detector signal path.

Key Path

More More QP/AVG
TEST 1 of 3 2 of 3 10X OFF

Related Programming Command

QPGAIN

QP DET
ON OFF

Softkey that turns the quasi-peak detector on and off. This is a service diagnostic function and is for service use only.

Key Path

More More Service
CALIBRATE 1 of 3 2 of 3 Diag More 1 ... More 6
QP DET
ON OFF

Related Programming Command

none

QP DWELL
TIME

Softkey that sets the measurement time when the quasi-peak detector is measured. This key is used in conjunction with **MEASURE AT MKR**, **RE-measure**, **AUTO-MEASURE**, and **MEAS STEPPED**.

Key Path

More Inst Measure QP DWELL
SETUP 1 of 3 Setup Detector TIME

Related Programming Command

MEASTIMEQPD

QP GAIN
ON OFF

Softkey that amplifies the video signal ten times (20 dB). This is a service diagnostic function and is for service use only.

Key Path

CALIBRATE More More Service
1 of 3 2 of 3 Diag More 1 ... More 6
QP GAIN
ON OFF

Related Programming Command

none

QPD
OFFSET

Softkey that sets the offset of the quasi-peak detector. This is a service diagnostic function and is for service use only.

Key Path

CALIBRATE More More Service
1 of 3 2 of 3 Diag More 1 ... More 6
QPD
OFFSET

Related Programming Command

none

QPD RST
ON OFF

Softkey that discharges and resets the quasi-peak detector. This is a service diagnostic function and is for service use only.

Key Path

CALIBRATE More More Service
1 of 3 2 of 3 Diag More 1 ... More 6
QPD RST
ON OFF

Related Programming Command

none

QUASI-PEAK

Hardkey that toggles the quasi-peak detector on and off. When on, the instrument is placed in linear amplitude detection, the detector is turned on, and the system settings are optimized to accurately measure the quasi-peak amplitudes.

Related Programming Command

none

QUIETJET

Softkey that specifies QuietJet as the printer connected to the output port.

Key Path

| | | | | | |
|---------------|--------|---------|--------|--------|----------|
| | Print | Printer | More | More | |
| CONFIG | Config | Type | 1 of 3 | 2 of 3 | QUIETJET |

Related Programming Command

none

RECALL

Hardkey that accesses softkey menus that allow you to recall data from the floppy disk or internal memory. When **Recall Internal** is selected, states, traces, and limit-line tables can be recalled from internal memory. When **Recall Disk** is selected, states, traces, limit-line tables, and amplitude-correction factors, display images, setups, and lists can be recalled from the floppy disk.

In addition, pressing **RECALL** accesses the cataloging functions used to catalog the saved data that is in internal memory or on the floppy disk.

Related Programming Command

SAVRCLF

**RECALL
ANTENNA**

Softkey that recalls antenna-correction factors from a floppy disk. To recall antenna-correction data press, **RECALL ANTENNA** use the step keys or knob to highlight the desired file, then press **LOAD FILE**.

Key Path

| | | |
|---------------|--------|---------|
| | Recall | RECALL |
| RECALL | Disk | ANTENNA |

Related Programming Command

AMPCOR

RECALL CABLE

Softkey that recalls cable-correction factors from a floppy disk. To recall cable factors press, **RECALL CABLE** use the step keys or knob to highlight the desired file, then press **LOAD FILE**.

Key Path

| | | | |
|---------------|--------|--------|--------|
| | Recall | More | RECALL |
| RECALL | Disk | 1 of 2 | CABLE |

Related Programming Command

AMPCOR

RECALL COLORS

Softkey that recalls previously saved display palettes (the color definitions for the features on the display) from the recall number specified. To recall a display palette press, **RECALL COLORS** the message **RECALL COLOR (1-4)** will be display on the top left-hand side of the display. Use the data keys to select the desired recall register.

Key Path

| | | | |
|----------------|---------|--------|--------|
| | Display | Adjust | RECALL |
| DISPLAY | Config | Color | COLORS |

Related Programming Command

RCLC

Recall Disk

Softkey that accesses a menu to recall instrument setups, signals lists, states, traces, display images, limit-line tables, and amplitude-correction factors from a floppy disk.

Key Path

| | |
|---------------|--------|
| | Recall |
| RECALL | Disk |

Related Programming Command

none

**Recall
Internal**

Softkey that accesses a menu to recall states, traces, and limit-line tables from internal memory.

Key Path

RECALL Recall
Internal

Related Programming Command

none

**RECALL
LIMITS**

Softkey that recalls limit-line tables from a floppy disk. To recall a limit-line table press, **RECALL LIMITS** use the step keys or knob to highlight the desired file, then press **LOAD FILE**.

Key Path

DISPLAY More Limit **RECALL**
1 of 2 Lines **LIMITS**

RECALL Recall **RECALL**
Disk **LIMITS**

SETUP More Limit **RECALL**
1 of 3 Lines **LIMITS**

Related Programming Command

none

**RECALL
LIST**

Softkey that recalls signal lists from a floppy disk. To recall a signal list press, **RECALL LIST** use the step keys or knob to highlight the desired file, then press **LOAD FILE**.

Key Path

RECALL Recall **RECALL**
Disk **LIST**

TEST More Save/Rcl **RECALL**
1 of 3 List **LIST**

Related Programming Command

none

**RECALL
OTHER**

Softkey that recalls *other* two-port device factors from a floppy disk. To recall *other* data press, **RECALL OTHER** use the step keys or knob to highlight the desired file, then press **LOAD FILE**.

Key Path

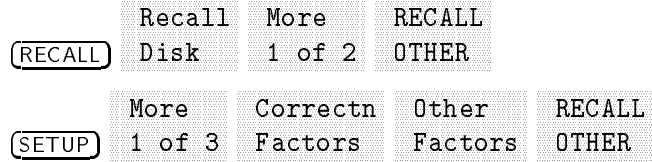

Related Programming Command

AMPCOR

**RECALL
SETUP**

Softkey that recalls instrument setups from a floppy disk. To recall an instrument setup press, **RECALL SETUP** use the step keys or knob to highlight the desired file, then press **LOAD FILE**.

Key Path

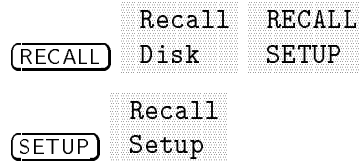

Related Programming Command

none

**RECALL
TRACE**

Softkey that recalls traces from a floppy disk. To recall a trace press, **RECALL TRACE** use the step keys or knob to highlight the desired file, then press **LOAD FILE**.

Key Path

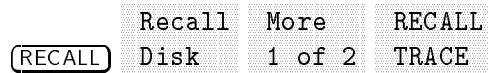

Related Programming Command

none

RECEIVER ADDRESS

Softkey that allows you to set the HP-IB address of the instrument. The address is set to 18 by pressing **DEFAULT CONFIG**.

Key Path

CONFIG **More** **RECEIVER**
1 of 3 **ADDRESS**

Related Programming Command

none

RED

Softkey that changes the intensity of the red portion of the primary light source output for the display annotation, trace, graticule, and so on.

Key Path

DISPLAY **Display** **Adjust** **Edit** **HSL**
Config **Color** **Colors** ... **RGB** **RED**

Related Programming Command

none

RED FILL

Softkey that replaces the standard display screen with a red box. This is one of 18 test patterns that can be used for display-troubleshooting and screen-alignment procedures.

Key Path

DISPLAY **Display** **Test** **More** **More**
Config **Patterns** 1 of 4 2 of 4 **RED FILL**

Related Programming Command

none

REF LVL

Softkey that allows the reference level to be changed. This function is activated when **AMPLITUDE** is pressed. The reference level is the amplitude power or voltage represented by the top graticule line on the screen. Changing the value of the reference level changes the absolute amplitude level (in dB μ V) of the top graticule line. The reference level can be changed using the data keys, knob, or step keys.

Key Path

AMPLITUDE REF LVL

Related Programming Command

RL

**REF LVL
OFFSET**

Softkey that adds an offset value to the displayed reference level. Offsets are entered by using the data keys. Entering an offset does not affect the trace or the attenuation value. Reference-level offsets are used when gain or loss occurs between a device under test and the instrument input. Thus, the signal level measured by the instrument is the level at the input of an external amplitude-conversion device. When an amplitude offset is entered, its value is displayed on the top left-side of the screen. To eliminate an offset, press **REF LVL OFFSET**, 0 **-dBm** or **+dBm**. Pressing **PRESET** also sets the offset to zero. See also the **EXTERNAL PREAMPG** softkey description.

Key Path

AMPLITUDE More More REF LVL
1 of 2 2 of 3 OFFSET

Related Programming Command

ROFFSET

**REMEAS
ALL SIGS**

Softkey that remeasures all signals in the signal list. To remeasure each signal the algorithm spans down on the signal using the initial frequency listed in the table. When zero span is reached, up to three detectors can be used to measure the signal. These detectors are selected using **DETECTOR PK QP AV**.

Key Path

TEST More EDIT Re- REMEAS
1 of 3 LIST measure ALL SIGS

Related Programming Command

REMEASSIG

REMEAS MARKED

Softkey that remeasures marked signals in the signal list. To remeasure each signal the algorithm spans down on the signal using the initial frequency listed in the table. When zero span is reached, up to three detectors can be used to measure the signal. These detectors are selected using `DETECTOR PK QP AV`.

Key Path

| | | | | |
|--------|--------|------|---------|--------|
| | More | EDIT | Re- | REMEAS |
| (TEST) | 1 of 3 | LIST | measure | MARKED |

Related Programming Command

REMEASSIG

REMEAS SIGNAL

Softkey that remeasures the signal specified in the signal list. To remeasure each signal the algorithm spans down on the signal using the initial frequency listed in the table. When zero span is reached, up to three detectors can be used to measure the signal. These detectors are selected using `DETECTOR PK QP AV`.

Key Path

| | | | | |
|--------|--------|------|---------|--------|
| | More | EDIT | Re- | REMEAS |
| (TEST) | 1 of 3 | LIST | measure | SIGNAL |

Related Programming Command

REMEASSIG

Re- measure

Softkey that accesses a menu that remeasures one or more signals in the signal list.

Key Path

| | | | | |
|--------|--------|------|---------|--|
| | More | EDIT | Re- | |
| (TEST) | 1 of 3 | LIST | measure | |

Related Programming Command

REMEASSIG

RESOLUTN LOW HIGH

Softkey that sets the resolution of subsequent prints to low or high resolution. High resolution shows more detail, but takes a longer time to print. Print resolution and print speed will vary with the printer type. Refer to the specific printer manual for more information.

Key Path

(CONFIG) Print Config Print Options RESOLUTN LOW HIGH

Related Programming Command

PRNTRES

RESTART

Softkey that restarts a stepped measurement. The stepped measurement is taken between the specified start and stop frequencies in conjunction with the selected step size (FREQ STEP), step type (STEP LOG LIN) and step mode (MEAS SNG CONT).

Key Path

(TEST) More 1 of 3 More 2 of 3 MEAS STEPPED STOP RESTART

(TEST) More 1 of 3 More 2 of 3 MEAS STEPPED FREQ STEP RESTART

Related Programming Command

none

SATUR- ATION

Softkey that changes the saturation (the ratio of pure color mixed with white) of the specified portion of the display annotation.

Key Path

(DISPLAY) Display Config Adjust Color Edit Colors ... HSL RGB SATUR- ATION

Related Programming Command

SETC

SAVE

Hardkey that accesses menus that allow you to store state data, trace data, and limit-line tables in internal memory. The SAVE function also allows you to save instrument setups, state data, trace data, limit-line tables, amplitude-correction factors, signal lists, and display images on the floppy disk. In addition, pressing **SAVE** accesses the menus used to catalog the saved data in internal memory or on the floppy disk.

Saving state data saves the instrument settings, but not the trace data. Saving trace data saves both the trace data and the state data. Display images can only be saved to or recalled from the floppy disk.

States and traces are saved in internal memory even if the instrument is turned off or **PRESET** is pressed. Eight internal state registers and many trace and limit-line registers are available for the user. The **Catalog Internal** softkey is used to access the catalog functions.

Related Programming Command

SAVRCLF

**SAVE
ANTENNA**

Softkey that saves antenna amplitude-correction data to a floppy disk. To save antenna data press, **SAVE ANTENNA**. **REGISTER #** and **PREFIX=** are displayed on the screen. Use the data keys to enter the desired register number then press **ENTER**. The message Saving to :FILENAME is displayed. The antenna data has now been saved to a disk.

Key Path

| | | | | |
|--------------|--------|----------|---------|---------|
| | More | Correctn | Antenna | SAVE |
| SETUP | 1 of 3 | Factors | Factors | ANTENNA |

Related Programming Command

AMPCOR

**SAVE
CABLE**

Softkey that saves cable amplitude-correction data to a floppy disk. To save cable data press, **SAVE CABLE**. **REGISTER #** and **PREFIX=** are displayed on the screen. Use the data keys to enter the desired register number then press **ENTER**. The message Saving to :FILENAME is displayed. The cable data has now been saved to a disk.

Key Path

| | | | | |
|--------------|--------|----------|---------|-------|
| | More | Correctn | Cable | SAVE |
| SETUP | 1 of 3 | Factors | Factors | CABLE |

Related Programming Command

AMPCOR

SAVE COLORS

Softkey that saves a display palette (the color definitions for the features on the display) to the save number specified. To save a display palette press, SAVE COLORS the message SAVE COLORS (1-4) will be displayed at the top left-hand side of the display. Use the data keys to select the desired register to save to.

Key Path

(DISPLAY) Display Adjust SAVE
Config Color COLORS

Related Programming Command

SAVEC

Save Disk

Softkey that accesses a menu to save instrument setups, signals lists, states, traces, display images, limit-line tables, and amplitude-correction factors to a floppy disk.

Key Path

(SAVE) Save
Disk

Related Programming Command

none

SAVE EDIT

Softkey that passes the text from the DLP editor memory through the parser to execute as instrument commands. If the text (commands) is a valid user-defined function, it passes through the parser and into the instrument user memory. It will replace an existing user defined function of the same name.

Key Path

(RECALL) Recall Catalog SAVE
Internal Internal ... * Editor EDIT

(SAVE) Save Catalog SAVE
Internal Internal ... * Editor EDIT

* Any of the following can be used to complete the key path:
CATALOG ALL, CATALOG VARIABLES, or CATALOG PREFIX.

Related Programming Command

none

Save
Internal

Softkey that accesses a menu to save states, traces, and limit-line tables to internal instrument memory.

Key Path

Save
(SAVE) Internal

Related Programming Command

none

SAVE
LIMITS

Softkey that saves the current limit-line table to a floppy disk. To save a limit-line table press, **SAVE LIMITS**. REGISTER # and PREFIX= are displayed on the screen. Use the data keys to enter the desired register number then press (ENTER). The message Saving to :FILENAME is displayed. The limit-line table has now been saved to a disk.

Key Path

More Limit SAVE
(DISPLAY) 1 of 2 Lines LIMITS
More Limit SAVE
(SETUP) 1 of 3 Lines LIMITS

Related Programming Command

none

SAVE LIN
GRAPH

Softkey that draws an EMI report graph on the display. **SAVE LIN GRAPH** draws a full-screen graticule, linear frequency-axis with limited annotation. Drop lines for peak amplitude signals with cross-bars for quasi-peak and average amplitude readings are drawn on the graticule. The quasi-peak cross-bar is the same color as trace B (default is blue) and the average cross-bar is the same color as trace C (default is magenta). The start and stop frequencies are defined based on the frequencies in the signal list.

Key Path

More Save/Rcl SAVE LIN
(TEST) 1 of 3 List GRAPH

Related Programming Command

SIGGRAPH

SAVE LIST

Softkey that saves the current signal list to a floppy disk. To save a signal list press, **SAVE LIST**. REGISTER # and PREFIX= are displayed on the screen. Use the data keys to enter the desired register number then press **ENTER**. The message Saving to :FILENAME is displayed. The signal list has now been saved to a disk.

CAUTION

When saving internal data and signal lists are displayed, disk warning messages do *not* appear. Therefore it is recommended that you verify that a file has been saved before clearing the data from your display.

For example, before saving signal list data, make sure that your disk is *not* write protected. To verify that the file was saved, press **RECALL LIST** to catalog signal lists that have been saved to the disk, then check that the correct file was saved by inspecting the file name, date, and time stamp.

Key Path

| | | | |
|-------------|--------|----------|------|
| | More | Save/Rcl | SAVE |
| TEST | 1 of 3 | List | LIST |

Related Programming Command

none

SAVE LOG GRAPH

Softkey that draws an EMI report graph on the display. **SAVE LOG GRAPH** draws a full-screen graticule, logarithmic frequency-axis with limited annotation. Drop lines for peak amplitude signals with cross-bars for quasi-peak and average amplitude readings are drawn on the graticule. The quasi-peak cross-bar is the same color as trace B (default is blue) and the average cross-bar is the same color as trace C (default is magenta). The start and stop frequencies are defined based on the frequencies in the signal list.

Key Path

| | | | |
|-------------|--------|----------|----------|
| | More | Save/Rcl | SAVE LOG |
| TEST | 1 of 3 | List | GRAPH |

Related Programming Command

SIGGRAPH

SAVE
OTHER

Softkey that saves *other* two-port amplitude-correction factors to a floppy disk. To save *other* amplitude-correction factors press, SAVE OTHER. REGISTER # and PREFIX= are displayed on the screen. Use the data keys to enter the desired register number then press **(ENTER)**. The message Saving to :FILENAME is displayed. *Other* two-port amplitude-correction data has now been saved to a disk.

Key Path

(SETUP) More Correctn Other SAVE
1 of 3 Factors Factors OTHER

Related Programming Command

AMPCOR

Save/Rcl
List

Softkey that accesses a menu used to save and recall signal lists. Save/Rcl List also draws report graphs on the display.

Key Path

(TEST) More Save/Rcl
1 of 3 List

Related Programming Command

none

SAVE
SETUP

Softkey that saves the current setup to a floppy disk. To save a setup press, SAVE SETUP. REGISTER # and PREFIX= are displayed on the screen. Use the data keys to enter the desired register number then press **(ENTER)**. The message Saving to :FILENAME is displayed. The setup has now been saved to a disk.

Key Path

(SETUP) More SAVE
1 of 3 SETUP

Related Programming Command

none

SAV LOCK ON OFF

Softkey that locks all the current internal state and trace registers against further data storage, when ON is underlined. With the state and trace memory locked, the **STATE -> INTRNL** and **Trace -> Intrnl** softkey functions are no longer accessible; the **MEM LOCKED** softkey function is displayed instead. Pressing **DEFAULT CONFIG** or **(PRESET)** sets **SAV LOCK ON OFF** to OFF.

Note

When **SAV LOCK ON OFF** is set to ON, none of the state registers can be overwritten, including state register nine. The instrument automatically updates state register nine with the last state unless the save lock function is on.

Key Path

(SAVE) **Save** **SAV LOCK**
Internal **ON OFF**

Related Programming Command

PSTATE

SCALE LOG LIN

Softkey that scales the vertical graticule divisions in logarithmic units when LOG is underlined. When LOG is the active function, the logarithmic units per division can be changed. Values may range from 0.1 to 20 dB per division. When LIN is underlined, the vertical scale is in linear mode which has a range of 1 kW to 1 pW. The reference-level value is set to the top of the screen and the bottom graticule becomes zero volts. (Each division of the graticule is one-eighth of the reference level in volts.)

Pressing **SCALE LOG LIN** always sets the units specified for the current amplitude scale. Pressing **(PRESET)** or powering on the instrument sets the default units.

Key Path

(AMPLITUDE) **SCALE**
LOG LIN

Related Programming Command

LG, LN

SELECT

Hardkey that directly accesses the menus that selects AM or FM demodulation, FM gain, dwell time, and squelch levels.

Related Programming Command

none

SELECT
1 2 3 4

Softkey that selects one of the four possible markers. A marker can be turned on once it is selected. A marker that has already been turned on will become active when it is selected. If a marker has already been turned on and assigned to a specific trace it will become active on that trace and the **MK TRACE AUTO ABC** softkey will have the appropriate trace letter underlined.

Key Path

SELECT
MKR 1 2 3 4

Related Programming Command

MKACT

SELECT
AMPLITUD

Softkey that enters either the amplitude value for the displayed (upper or lower) limit-line segment or the amplitude value for the current amplitude-correction point. Enter the amplitude value for the selected frequency (or time, for signal analysis mode only) by using the data keys. Change an amplitude value by using the step keys or the knob. Press **BK SP** to correct errors.

Key Path

More **Correctn** **SELECT**
SETUP 1 of 3 **Factors** ... * **AMPLITUD**

Receiver mode

More **Limit** **EDIT** **SELECT**
DISPLAY 1 of 2 **Lines** ... † **LIMIT** **AMPLITUD**

More **Limit** **EDIT** **SELECT**
SETUP 1 of 3 **Lines** ... † **LIMIT** **AMPLITUD**

Signal analysis mode

More **Limit** **Edit** **SELECT**
DISPLAY 1 of 2 **Lines** **Limit** ... § **AMPLITUD**

More **Limit** **Edit** **SELECT**
SETUP 1 of 3 **Lines** **Limit** ... § **AMPLITUD**

* Any of the following group of softkeys can be used to complete the key path:
 Antenna Factors , EDIT ANTENNA , or Cable Factors , EDIT CABLE
 or Other Factors , EDIT OTHER .

† Either Limit 1 or Limit 2 can be used to complete the key path.

§ Either EDIT UPPER, or EDIT LOWER can be used to complete the key path.

Related Programming Command

AMPCOR, LIMSEG

Select
Axis

Softkey that accesses a menu which allows the selection of the frequency and the amplitude scales for the limit line to be either logarithmic or linear.

Key Path

| | | | | | | |
|-----------|--------|-------|-----|---------|--------|--------|
| | More | Limit | | EDIT | Select | Select |
| (DISPLAY) | 1 of 2 | Lines | ... | * LIMIT | Type | Axis |

| | | | | | | |
|---------|--------|-------|-----|---------|--------|--------|
| | More | Limit | | EDIT | Select | Select |
| (SETUP) | 1 of 3 | Lines | ... | * LIMIT | Type | Axis |

* Either Limit 1 or Limit 2 can be used to complete the key path.

Related Programming Command

none

SELECT
DELT AMP

Softkey that sets the delta amplitude value for a segment of a mid/delta type of limit line. Press (BK SP) to correct errors.

Key Path

| | | | | | |
|-----------|--------|-------|-------|----------|----------|
| | More | Limit | Edit | EDIT | SELECT |
| (DISPLAY) | 1 of 2 | Lines | Limit | MID/DELT | DELT AMP |

| | | | | | |
|---------|--------|-------|-------|----------|----------|
| | More | Limit | Edit | EDIT | SELECT |
| (SETUP) | 1 of 3 | Lines | Limit | MID/DELT | DELT AMP |

Related Programming Command

none

SELECT FREQ

Softkey that enters the frequency value for a limit-line segment or for an amplitude-correction point. Enter the frequency value for the frequency by using the data keys. Change the frequency value by using the step keys or the knob. Press **[BK SP]** to correct errors.

A frequency coordinate must always be specified for either limit lines or amplitude-correction factors.

Note

Limit-line data is sorted in frequency order in the limit-line table. The sorting occurs after you have entered the frequency and at least one amplitude value.

For amplitude-correction factors, only two entries with the same frequency are valid. Only the first and last points of a series with the same frequency values are used; the middle points are ignored.

Amplitude-correction data is sorted in the table by frequency. The sorting occurs immediately after you have entered the frequency value via the front panel.

Key Path

[SETUP] More 1 of 3 Correctn Factors ... * **[SELECT]**
[FREQ]

Receiver mode

[DISPLAY] More 1 of 2 Limit Lines ... † **[EDIT]** **[LIMIT]** **[SELECT]**
[FREQ]

[SETUP] More 1 of 3 Limit Lines ... † **[EDIT]** **[LIMIT]** **[SELECT]**
[FREQ]

Signal analysis mode

[DISPLAY] More 1 of 2 Limit Lines Edit Limit ... § **[SELECT]**
[FREQ]

[SETUP] More 1 of 3 Limit Lines Edit Limit ... § **[SELECT]**
[FREQ]

* Any of the following groups of softkeys can be used to complete the key path:
[Antenna Factors], **[EDIT ANTENNA]**, or **[Cable Factors]**, **[EDIT CABLE]**
or **[Other Factors]**, **[EDIT OTHER]**.

† Either **[Limit 1]** or **[Limit 2]** can be used to complete the key path.

§ Any of the following keys can be used to complete the key path:
[EDIT UPPER], **[EDIT LOWER]**, **[EDIT UP/LOW]** or **[EDIT MID/DELT]**.

Related Programming Command

AMPCOR, LIMISEG

**SELECT
FRM LIST**

Softkey that controls the cursor position in the signal list.

Key Path

| | | |
|--------|--------|----------|
| | More | SELECT |
| (TEST) | 1 of 3 | FRM LIST |

| | | | |
|--------|--------|------|----------|
| | More | EDIT | SELECT |
| (TEST) | 1 of 3 | LIST | FRM LIST |

| | | | | |
|--------|--------|------|---------|----------|
| | More | EDIT | Sort | SELECT |
| (TEST) | 1 of 3 | LIST | Signals | FRM LIST |

| | | | | |
|--------|--------|------|---------|----------|
| | More | EDIT | Delete | SELECT |
| (TEST) | 1 of 3 | LIST | Signals | FRM LIST |

Related Programming Command

SIGPOS

**SELECT
LWR AMPL**

Signal analysis mode only.

Softkey that enters the amplitude value for the lower limit-line segment. Enter the amplitude value for the selected frequency or time by using the knob or data keys. Press (BK SP) to correct errors.

Key Path

| | | | | | |
|-----------|--------|-------|-------|--------|----------|
| | More | Limit | Edit | EDIT | SELECT |
| (DISPLAY) | 1 of 2 | Lines | Limit | UP/LOW | LWR AMPL |

| | | | | | |
|---------|--------|-------|-------|--------|----------|
| | More | Limit | Edit | EDIT | SELECT |
| (SETUP) | 1 of 3 | Lines | Limit | UP/LOW | LWR AMPL |

Related Programming Command

none

**SELECT
MID AMPL**

Signal analysis mode only.

Softkey that enters the amplitude value for the middle of the limit-line segment. Enter the amplitude value for the selected frequency or time by using the knob or data keys. Press (BK SP) to correct errors.

Key Path

| | | | | | |
|-----------|--------|-------|-------|----------|----------|
| | More | Limit | Edit | EDIT | SELECT |
| (DISPLAY) | 1 of 2 | Lines | Limit | MID/DELT | MID AMPL |

| | | | | | |
|---------|--------|-------|-------|----------|----------|
| | More | Limit | Edit | EDIT | SELECT |
| (SETUP) | 1 of 3 | Lines | Limit | MID/DELT | MID AMPL |

Related Programming Command

none

SELECT POINT

Softkey that creates or edits an amplitude-correction factor data point. Enter the point number to be created or edited by using the data keys, then press **(ENTER)**. Press **(BK SP)** to correct errors.

Key Path

| | | | | | |
|----------------|--------|----------|---------|---------|--------|
| | More | Correctn | Antenna | Edit | SELECT |
| (SETUP) | 1 of 3 | Factors | Factors | Antenna | POINT |

| | | | | | |
|----------------|--------|----------|---------|-------|--------|
| | More | Correctn | Cable | Edit | SELECT |
| (SETUP) | 1 of 3 | Factors | Factors | Cable | POINT |

| | | | | | |
|----------------|--------|----------|---------|-------|--------|
| | More | Correctn | Other | Edit | SELECT |
| (SETUP) | 1 of 3 | Factors | Factors | Other | POINT |

Related Programming Command

AMPCOR

SELECT PREFIX

Softkey that allows you to select an already existing prefix of a cataloged file and changes the current prefix to this selected prefix. This provides a convenient method for saving and recalling data to and from the floppy disk and for cataloging by the prefix. Use either the knob or step keys to select the file.

Key Path

| | | | |
|-----------------|--------|-------|--------|
| | Recall | | SELECT |
| (RECALL) | Disk | ... * | PREFIX |

| | | | | |
|-----------------|--------|--------|-------|--------|
| | Recall | More | | SELECT |
| (RECALL) | Disk | 1 of 2 | ... † | PREFIX |

| | | | | |
|-----------------|----------|----------|-------|--------|
| | Recall | Catalog | | SELECT |
| (RECALL) | Internal | Internal | ... ‡ | PREFIX |

| | | | |
|---------------|------|---------|--------|
| | Save | CATALOG | SELECT |
| (SAVE) | Disk | DISK | PREFIX |

| | | | | |
|---------------|----------|----------|-------|--------|
| | Save | Catalog | | SELECT |
| (SAVE) | Internal | Internal | ... § | PREFIX |

| | | |
|----------------|--------|--------|
| | RECALL | SELECT |
| (SETUP) | SETUP | PREFIX |

| | | | | |
|----------------|--------|----------|-----|--------|
| | More | Correctn | | SELECT |
| (SETUP) | 1 of 3 | Factors | ... | PREFIX |

| | | | | |
|--------|--------|----------|--------|--------|
| | More | Save/Rcl | RECALL | SELECT |
| (TEST) | 1 of 3 | List | LIST | PREFIX |

Receiver mode

| | | | | |
|-----------|--------|-------|--------|--------|
| | More | Limit | RECALL | SELECT |
| (DISPLAY) | 1 of 2 | Lines | LIMITS | PREFIX |

* Any of the following keys can be used to complete the key path:
 CATALOG DISK , RECALL SETUP , RECALL LIST , RECALL LIMITS ,
 or RECALL ANTENNA .

† Any of the following keys can be used to complete the key path:
 RECALL CABLE , RECALL OTHER , or RECALL TRACE .

‡ Any of the following keys can be used to complete the key path:
 CATALOG ALL , CATALOG VARIABLES , or CATALOG PREFIX .

§ Any of the following keys can be used to complete the key path:
 CATALOG ALL , CATALOG REGISTER , CATALOG VARIABLES
 or CATALOG PREFIX .

|| Any of the following groups of softkeys can be used to complete the key path:
 Antenna Factors , EDIT ANTENNA , or Cable Factors , EDIT CABLE
 or Other Factors , EDIT OTHER .

Related Programming Command

none

SELECT SEGMENT

Softkey that creates or edits a limit-line segment. Limit lines are created by entering frequency (or time) and amplitude values into a limit-line table. The frequency (or time, for signal analysis mode only) and amplitude values specify a coordinate point from which a limit-line segment is drawn. The coordinate point is the lowest frequency or time point of the line segment. Limit lines are constructed from left to right. To select a segment, press **SELECT SEGMENT** , enter the segment number you wish to specify, then press a units key.

Up to 30 segments can be specified per limit-line table.

Receiver mode

| | | | | | |
|-----------|--------|-------|-------|-------|---------|
| | More | Limit | | EDIT | SELECT |
| (DISPLAY) | 1 of 2 | Lines | ... * | LIMIT | SEGMENT |

| | | | | | | |
|-----------|--------|-------|-------|-------|--------|---------|
| | More | Limit | | EDIT | More | SELECT |
| (DISPLAY) | 1 of 2 | Lines | ... * | LIMIT | 1 of 2 | SEGMENT |

| | | | | | | |
|----------------|----------------|----------------|-------|---------------|-------------------|-------------------|
| DISPLAY | More 1 of 2 | Limit Lines | ... * | EDIT LIMIT | Select Type | SELECT SEGMENT |
| SETUP | More 1 of 3 | Limit Lines | ... * | EDIT LIMIT | SELECT SEGMENT | |
| SETUP | More 1 of 3 | Limit Lines | ... * | EDIT LIMIT | More 1 of 2 | SELECT SEGMENT |
| SETUP | More 1 of 3 | Limit Lines | ... * | EDIT LIMIT | Select Type | SELECT SEGMENT |

Key Path

Signal analysis mode

| | | | | | | |
|----------------|----------------|----------------|---------------|-------|-------------------|-------------------|
| DISPLAY | More 1 of 2 | Limit Lines | Edit Limit | ... † | SELECT SEGMENT | |
| DISPLAY | More 1 of 2 | Limit Lines | Edit Limit | ... † | More 1 of 2 | SELECT SEGMENT |
| SETUP | More 1 of 3 | Limit Lines | Edit Limit | ... † | SELECT SEGMENT | |
| SETUP | More 1 of 3 | Limit Lines | Edit Limit | ... † | More 1 of 2 | SELECT SEGMENT |

* Either **Limit 1** or **Limit 2** can be used to complete the key path.

† Any of the following can be used to complete the key path:
EDIT UPPER, **EDIT LOWER**, **EDIT UP/LOW**, or **EDIT MID/DEL**.

Related Programming Command

none

Select Type

Softkey that accesses the menu used to select the limit-line type of line. Press **FLAT** to select a flat line, press **SLOPE** to select a sloped line, or press **POINT** to select a point.

Key Path

Receiver mode

| | | | | | |
|----------------|----------------|----------------|-------|---------------|----------------|
| DISPLAY | More 1 of 2 | Limit Lines | ... * | EDIT LIMIT | Select Type |
| SETUP | More 1 of 3 | Limit Lines | ... * | EDIT LIMIT | Select Type |

Signal analysis mode

| | | | | | | |
|-----------|----------------|----------------|---------------|-----|---|----------------|
| (DISPLAY) | More 1 of 2 | Limit Lines | Edit Limit | ... | † | Select Type |
| (SETUP) | More 1 of 3 | Limit Lines | Edit Limit | ... | † | Select Type |

* Either **Limit 1** or **Limit 2** can be used to complete the key path.

† Any of the following can be used to complete the key path:
EDIT UPPER, **EDIT LOWER**, **EDIT UP/LOW**, or **EDIT MID/DELT**.

Related Programming Command

none

**SELECT
UPR AMPL**

Signal Analysis mode only.

Softkey that enters the amplitude value for the upper limit-line segment. Enter the amplitude value for the selected frequency or time by using the knob or data keys. Press **(BK SP)** to correct errors.

Key Path

| | | | | | |
|-----------|----------------|----------------|---------------|----------------|--------------------|
| (DISPLAY) | More 1 of 2 | Limit Lines | Edit Limit | EDIT UP/LOW | SELECT UPR AMPL |
| (SETUP) | More 1 of 3 | Limit Lines | Edit Limit | EDIT UP/LOW | SELECT UPR AMPL |

Related Programming Command

none

**Selectv
Mark**

Softkey that accesses a menu that marks one or more signals on the signal list.

Key Path

| | | | | |
|--------|----------------|--------------|-------------------|-----------------|
| (TEST) | More 1 of 3 | EDIT LIST | Signal Marking | Selectv Mark |
|--------|----------------|--------------|-------------------|-----------------|

Related Programming Command

SIGMARK

**Service
Cal**

Softkey that accesses several service calibration functions. The service calibration functions are designed for service use only.

Key Path

| | | | |
|------------------|--------|--------|---------|
| | More | More | Service |
| CALIBRATE | 1 of 3 | 2 of 3 | Cal |

Related Programming Command

none

**Service
Diag**

Softkey that accesses several service diagnostic functions. The service diagnostic functions are designed for service use only.

Key Path

| | | | |
|------------------|--------|--------|---------|
| | More | More | Service |
| CALIBRATE | 1 of 3 | 2 of 3 | Diag |

Related Programming Command

none

**SET ATTN
ERROR**

Softkey that sets the calibration attenuator-error factors (this is not the same as the input attenuator). This is a service calibration function and is for service use only.

Key Path

| | | | | |
|------------------|--------|--------|---------|----------|
| | More | More | Service | SET ATTN |
| CALIBRATE | 1 of 3 | 2 of 3 | Cal | ERROR |

Related Programming Command

none

**SET
DATE**

Softkey that allows you to set the date of the real-time clock. To enter the date in the YYMMDD format use the data keys then press **ENTER**. Valid year (YY) values are 00 through 99. Valid month (MM) values are from 01 to 12, and valid day values are from 01 to 31.

Key Path

| | | | |
|---------------|--------|------|------|
| | More | Time | SET |
| CONFIG | 1 of 3 | Date | DATE |

Related Programming Command

SETDATE

**SET
TIME**

Softkey that allows you to set the time of the real-time clock. To enter the time in 24 hour, HHMMSS format, use the data keys then press **ENTER**. Valid hour (HH) values are from 00 to 23. Valid minute (MM) and second (SS) values are from 00 to 59.

Key Path

CONFIG More Time SET
1 of 3 Date TIME

CALIBRATE Cal At SET
Time TIME

Related Programming Command

CALTIME, SETTIME

**SETTINGS
ON OFF**

Softkey that turns on or off the generation of a tabular listing of current instrument settings. The listing will be sent to the printer when **OUTPUT REPORT** is executed.

Key Path

OUTPUT Define SETTINGS
Report ON OFF

Related Programming Command

none

SETUP

Hardkey that accesses softkey functions that control the receiver settings to be used in a measurement, such as frequency range, antenna correction factors, and limit lines.

Related Programming Command

none

SETUP
-> DISK

Softkey that stores the settings of the instrument to the disk. This includes: windows and the states associated with them, limit lines, correction factors, and other settings.

Key Path

Save SETUP
(SAVE) Disk -> DISK

Related Programming Command

none

SHOW Δ1
PK QP AV

Softkey that specifies that any or all of the following are included in the list portion of the report: peak detector delta from limit 1, quasi-peak detector delta from limit 1, or average detector delta from limit 1.

Key Path

Define SHOW Δ1
(OUTPUT) List PK QP AV

Related Programming Command

TBLDEF

SHOW Δ2
PK QP AV

Softkey that specifies that any or all of the following are included in the list portion of the report: peak detector delta from limit 2, quasi-peak detector delta from limit 2, or average detector delta from limit 2.

Key Path

Define SHOW Δ2
(OUTPUT) List PK QP AV

Related Programming Command

TBLDEF

SHOW COR
ON OFF

Softkey that specifies the total correction factors are included as part of the list portion of the report. The listing is sent to the printer upon receipt of an `OUTPUT REPORT`.

Key Path

| | | |
|---------------------|--------|----------|
| | Define | SHOW COR |
| <code>OUTPUT</code> | List | ON OFF |

Related Programming Command

TBLDEF

SHOW DET
PK QP AV

Softkey that specifies that any or all of the following are included in the list portion of the report: the peak detector, quasi-peak detector, and the average detector. The listing is sent to the printer upon receipt of an `OUTPUT REPORT`.

Key Path

| | | |
|---------------------|--------|----------|
| | Define | SHOW DET |
| <code>OUTPUT</code> | List | PK QP AV |

Related Programming Command

TBLDEF

SHOW MKR
ON OFF

Softkey that specifies signals that are marked in the signal list will be included as part of the list portion of the report.

Key Path

| | | |
|---------------------|--------|----------|
| | Define | SHOW MKR |
| <code>OUTPUT</code> | List | ON OFF |

Related Programming Command

TBLDEF

**SHOW
SETUP**

Softkey that shows current settings of the instrument on the display. **SHOW SETUP** consists of four pages of information, including existing filenames, correction-factor data, limit-line data, frequency settings, trace data, and so on. To access each succeeding page of information press **NEXT PAGE**. To exit, press **Previous Menu**.

Key Path

More **SHOW**
(SETUP) 1 of 3 **SETUP**

Related Programming Command

SHOWSETUP

**SHW INST
CONFIG**

Softkey that displays information about the configuration of the instrument including; model number, serial number, and the firmware revision date. Also included are the specific devices installed; HP-IB interface, RS-232 interface, tracking generator (TG), quasi-peak detector (QPD), FM demodulator (Demod), precision frequency reference (oven), narrow bandwidths (NBW), and additional information about the disk drive (DISK).

Key Path

More **More** **SHW INST**
(CONFIG) 1 of 3 **2 of 3** **CONFIG**

Related Programming Command

HAVE, ID, REF, SER

**SIG LIST
ON OFF**

Softkey that turns on or off the signal list viewing and editing functions.

Key Path

More **SIG LIST**
(TEST) 1 of 3 **ON OFF**

Related Programming Command

SIGLIST

SIGNAL ANALYSIS

Softkey that configures the instrument as a signal analyzer.

Key Path

(MODE) SIGNAL ANALYSIS

Related Programming Command

none

Signal Marking

Softkey that accesses a menu to mark one or more signal on the signal list.

Key Path

(TEST) More 1 of 3 EDIT LIST Signal Marking

Related Programming Command

SIGMARK

(SINGLE)

Hardkey that initiates a sweep when in single-sweep mode.

Related Programming Command

none

SLOPE

Softkey that draws a straight line between the coordinate point of the current segment and the coordinate point of the next segment, producing limit-line values for all frequencies between the two points.

Key Path

Receiver mode

(DISPLAY) More 1 of 2 Limit Lines ... * EDIT LIMIT Select Type SLOPE

(SETUP) More 1 of 3 Limit Lines ... * EDIT LIMIT Select Type SLOPE

Signal analysis mode

(DISPLAY) More 1 of 2 Limit Lines Edit Limit ... † Select Type SLOPE

(SETUP) More 1 of 3 Limit Lines Edit Limit ... † Select Type SLOPE

* Either `Limit 1` or `Limit 2` can be used to complete the key path.

† Any of the following can be used to complete the key path:
`EDIT UPPER`, `EDIT LOWER`, `EDIT UP/LOW`, or `EDIT MID/DELT`.

Related Programming Command

none

SOFTKEYS

Softkey that activates the softkey portion of the display screen for color editing.

Key Path

```
Display  Adjust  Edit  More  More
(DISPLAY) Config  Color  Colors  1 of 3  2 of 3
SOFTKEYS
```

Related Programming Command

SETC

SORT BY AVG AMP

Softkey that sorts the internal signal list by average amplitude. This list is sorted in descending order.

Key Path

```
More  EDIT  Sort  SORT BY
(TEST) 1 of 3 LIST Signals AVG AMP
```

Related Programming Command

SIGSORT

SORT BY FREQ

Softkey that sorts the internal signal list by the frequency of the signals. The list will be sorted in ascending order.

Key Path

```
More  EDIT  Sort  SORT BY
(TEST) 1 of 3 LIST Signals FREQ
```

Related Programming Command

SIGSORT

**SORT BY
DLTA LIM**

*This key is only active when **VIEW Δ OFF** is pressed first.*

Softkey that sorts the internal signal list by delta limits. The list will be sorted in descending order.

Key Path

(TEST) More 1 of 3 EDIT LIST Sort Signals **SORT BY
DLTA LIM**

Related Programming Command

SIGSORT

**SORT BY
PK AMP**

Softkey that sorts the internal signal list by peak amplitude. The list will be sorted by descending order.

Key Path

(TEST) More 1 of 3 EDIT LIST Sort Signals **SORT BY
PK AMP**

Related Programming Command

SIGSORT

**SORT BY
QP AMP**

Softkey that sorts the internal signal list by quasi-peak amplitude. The list will be sorted by descending order.

Key Path

(TEST) More 1 of 3 EDIT LIST Sort Signals **SORT BY
QP AMP**

Related Programming Command

SIGSORT

**Sort
Signals**

Softkey that accesses a menu to sort the internal signal list based on the softkey selected. Softkeys available are:

- **SORT BY FREQ**
- **SORT BY PK AMP**
- **SORT BY QP AMP**
- **SORT BY AVG AMP**
- **SORT BY DLTA LIM**

SORT BY DLTA LIM is only available when **VIEW Δ OFF** is pressed.

Key Path

TEST More EDIT Sort
1 of 3 LIST Signals

Related Programming Command

SIGSORT

SPAN or **SPAN**

Hardkey and softkey that activates the SPAN function and accesses the frequency-span functions. Pressing **SPAN** allows the user to change the frequency range symmetrically about the center frequency. The frequency-span readout describes the total displayed frequency range; to determine frequency span per horizontal graticule division, divide the frequency span by 10.

Key Path

SPAN SPAN

Related Programming Command

SP

**SPAN
ZOOM**

Softkey that finds the highest signal peak onscreen. If a marker is not already on the peak, it places a marker on it, turns on the marker-track function, and activates the span function. Pressing **SPAN ZOOM** performs the routine similar to pressing the following keys: **PEAK SEARCH**, **MARKER FUNCTION**, **MK TRACK ON OFF (ON)**, and **SPAN**.

Key Path

SPAN SPAN
SPAN ZOOM

Related Programming Command

SPZOOM

SPEAKER ON OFF

Softkey that turns the internal speaker on and off. The volume from the speaker is controlled by the front-panel volume control knob and FM GAIN (when using FM demodulation). There is no output from the speaker unless demodulation is turned on. Pressing (PRESET) sets SPEAKER ON OFF to ON.

Key Path

(SELECT) SPEAKER
ON OFF

Related Programming Command

SPEAKER

Special Colors

Softkey that accesses a menu of predefined color schemes designed to enhance viewing under specific situations. These color schemes are Monochrome, Vision Enhance 1 and 2 (for two types of deficient blindness), and Optical Filter (to accommodate the use of protective goggles when viewing lasers).

Key Path

(DISPLAY) Display Adjust Special
Config Colors Colors

Related Programming Commands

SETC

SQUELCH

Softkey that adjusts the squelch level. The squelch level mutes weak signals and passes strong signals. The squelch level affects the audio output only. If the internal speaker is on, audio signals are not output unless the signal strength exceeds the squelch threshold. The squelch level does not affect the rear-panel AUX VIDEO OUT signal. Squelch level is indicated onscreen by the unitless numbers 0 to 100, with 0 being minimum squelch threshold (all signals are passed), and 100 being maximum squelch threshold (no signals are passed). The default squelch value is 0.

Key Path

(SELECT) SQUELCH

Related Programming Command

SQLCH

SRC ATN
MAN AUTO

Softkey that allows you to select between automatic and manual adjustment of the tracking generator's switching attenuator. It can be manually adjusted from 0 to 56 dB in 8 dB steps. When auto-coupled, the SRC ATN function automatically adjusts the attenuator to yield the source amplitude level specified by the SRC PWR ON OFF softkey function. Set SRC ATN MAN AUTO so that MAN is underlined (decoupled) for power sweeps greater than 8 dB.

Key Path

TRACK GEN SRC ATN
MAN AUTO

Related Programming Command

SRCAT

SRC PWR
OFFSET

Softkey that offsets the displayed power of the tracking generator (SRC). Offset values may range from -327 dB to +327 dB.

Using the source-power-offset capability of the tracking generator allows you to take system losses or gains into account, thereby displaying the actual power delivered to the device under test.

Key Path

TRACK GEN More SRC PWR
1 of 2 OFFSET

Related Programming Command

SRCPOFS

SRC PWR
ON OFF

Softkey that activates (ON) or deactivates (OFF) the output power of the tracking generator (SRC). The power level can then be adjusted using the data keys, step keys, or knob.

Key Path

TRACK GEN SRC PWR
ON OFF

Related Programming Command

SRCPWR

SRC PWR
STP SIZE

Softkey that sets the step size of the source-power level, source-power offset, and power-sweep range functions. The step size may be values from -327 dB to 327 dB. The default setting is one vertical scale division.

Key Path

More SRC PWR
(TRACK GEN) 1 of 2 STP SIZE

Related Programming Command

SRCPSTP

START
FREQ

Softkey that sets the frequency at the left side of the graticule. The left and right sides of the graticule correspond to the start and stop frequencies. When these frequencies are activated, their values are displayed below the graticule in place of center frequency and span.

Key Path

START
(FREQUENCY) FREQ

Related Programming Command

FA

STATE
-> INTRNL

Softkey that saves the current instrument state in the selected state register. To save the current state, press STATE -> INTRNL, and use the data keys to enter a state register number (valid state register numbers are 1 through 8). If windows are being used, only the state of the active window will be saved.

Key Path

Save STATE
(SAVE) Internal -> INTRNL

Related Programming Command

SAVES

STATUS

Softkey that activates the status portion of the display screen for color editing.

Key Path

DISPLAY Display Adjust Edit More More
Config Color Colors 1 of 3 2 of 3 STATUS

Related Programming Command

SETC

**STEP
LOG LIN**

Softkey that initiates a logarithmic or linear stepped measurement. The stepped measurement is taken between the specified start and stop frequencies in conjunction with the selected step size (FREQ STEP), and step mode (MEAS SNG CONT). The parameter specified is multiplied by the intermediate frequency bandwidth to determine the actual step size.

Key Path

SETUP More Inst More STEP
1 of 3 Setup 1 of 2 LOG LIN

Related Programming Command

none

STOP

Softkey that stops a stepped measurement.

Key Path

TEST More More MEAS
1 of 3 2 of 3 STEPPED STOP

Related Programming Command

none

**STOP
FREQ**

Softkey that sets the frequency at the right side of the graticule. The left and right sides of the graticule correspond to the start and stop frequencies. When these frequencies are activated, their values are displayed below the graticule in place of center frequency and span.

Key Path

FREQUENCY STOP
FREQ

Related Programming Command

FB

**STORE
FLATNESS**

*This key is only active when either **EDIT FLATNESS** or **EDIT PA FLATNESS** are pressed first.*

Softkey that stores amplitude versus frequency calibration factors.

Key Path

| | | | | | |
|--------------------|--------|--------|---------|----------|----------|
| | More | More | Service | Flatness | STORE |
| (CALIBRATE) | 1 of 3 | 2 of 3 | Cal | Data | FLATNESS |

Related Programming Commands

none

**STOR PWR
ON UNITS**

Softkey that sets the default settings for the units used in the linear and the logarithmic modes when the instrument is powered on. The settings for the units can be changed during normal instrument operation but they will return to the default settings when the instrument is powered on again. This is a service calibration function.

Key Path

| | | | | |
|--------------------|--------|--------|---------|----------|
| | More | More | Service | STOR PWR |
| (CALIBRATE) | 1 of 3 | 2 of 3 | Cal | ON UNITS |

Related Programming Command

none

**STP GAIN
ZERO**

Softkey that disables the two 20 dB step-gain amplifiers on the A12 amplitude control assembly. This is a service diagnostic function and is for service use only.

Key Path

| | | | | |
|--------------------|--------|--------|---------|----------|
| | More | More | Service | STP GAIN |
| (CALIBRATE) | 1 of 3 | 2 of 3 | Diag | ZERO |

Related Programming Command

none

STUVWX

Softkey that accesses the menu used for selecting screen title or prefix characters S through X.

Key Access

(CAL), (CONFIG), (DISPLAY), (RECALL), (SAVE), or (SETUP)

Related Programming Command

none

(SWEEP)

Hardkey that accesses the sweep-time menu and the sweep-time softkey functions SWP TIME AUTO MAN and SWEEP CONT SGL.

Related Programming Command

CONTS

SWEEP
CONT SGL

Softkey that switches the instrument between continuous-sweep mode and single-sweep mode. If the instrument is in single-sweep mode, SGL is underlined. Press (SINGLE) to enable a sweep when in single-sweep mode. When continuous-sweep mode is in use, one sweep follows another as soon as it is triggered. Pressing (PRESET) and turning the power on, selects continuous sweep.

Key Path

(SWEEP) SWEEP
CONT SGL

(TRIG) SWEEP
CONT SGL

Related Programming Command

CONTS, SNGLS

SWEEP
LOG LIN

Softkey that selects between a logarithmic and linear frequency axis.

Key Path

(FREQUENCY) SWEEP
LOG LIN

(SWEEP) SWEEP
LOG LIN

Related Programming Commands

SWEEPTYPE

SWEEP
RAMP

Softkey that displays the RAMP signal from the sweep-ramp generator that is located on the A7 analog interface assembly. This is a service diagnostic function and is for service use only.

Key Path

| | | | | | |
|-------------|--------|--------|---------|--------|--------|
| | More | More | Service | | |
| (CALIBRATE) | 1 of 3 | 2 of 3 | Diag | More 1 | More 2 |
| SWEEP | | | | | |
| RAMP | | | | | |

Related Programming Command

none

SWEEP
TIME DAC

Softkey that displays the output of the sweep-time DAC (SWP_DAC) from the sweep-ramp generator that is on the A7 analog interface assembly. This is a service diagnostic function and is for service use only.

Key Path

| | | | | | |
|-------------|--------|--------|---------|--------|--------|
| | More | More | Service | | |
| (CALIBRATE) | 1 of 3 | 2 of 3 | Diag | More 1 | More 2 |
| SWEEP | | | | | |
| TIME DAC | | | | | |

Related Programming Command

none

SWP CPLG
SR RECV

Softkey that selects stimulus-response (SR) or receiver (RECV) auto-coupled sweep time. In stimulus-response mode, auto-coupled sweep times are usually much faster for swept-response measurements. Stimulus-response auto-coupled sweep times are typically valid in stimulus-response measurements when the frequency span of the instrument is less than 20 times the bandwidth of the device under test.

Key Path

| | | |
|-------------|--------|----------|
| | More | SWP CPLG |
| (TRACK GEN) | 1 of 2 | SR RECV |

Related Programming Command

MEASURE, SWPCPL

SWP TIME
AUTO MAN

Softkey that selects the length of time in which the instrument sweeps the displayed frequency span. In all non-zero frequency spans, the sweep time varies from 20 milliseconds to 100 seconds. In zero frequency span, the fastest sweep time is 15 milliseconds. Reducing the sweep time increases the rate of sweeps. The sweep time can be changed using the step keys, the knob, or the data keys.

Key Path

(AUTO COUPLE) SWP TIME
AUTO MAN

(SWEEP) SWP TIME
AUTO MAN

Related Programming Command

ST

(TEST)

Hardkey that provides control for measuring signals and manipulating lists of measured signals.

Related Programming Command

none

Test
Patterns

Softkey that accesses a menu consisting of 18 test patterns used for display-troubleshooting and screen-alignment procedures.

Key Path

(DISPLAY) Display Test
Config Patterns

Related Programming Command

none

THINKJET

Softkey that specifies ThinkJet as the printer connected to the output port.

Key Path

(CONFIG) Print Config Printer Type THINKJET

Related Programming Command

PRNTTYPE

THRESHLD ON OFF

Softkey that sets a lower boundary to the active trace. The threshold line “clips” signals that appear below the line when this function is on. The boundary is defined in amplitude units that correspond to its vertical position when compared to the reference level.

The value of the threshold appears in the active-function block and on the lower-left side of the screen. The threshold level does not influence the trace memory or marker position. The peaks found by the markers must be at least the peak-excursion value above the threshold level. The value of the threshold level can be changed using the step keys, the knob, or the data keys. If a threshold is active, press THRESHLD ON OFF until OFF is selected to turn the threshold display off. The threshold value affects peak searching even when the THRESHLD function is set to off.

Key Path

(DISPLAY) More 1 of 2 THRESHLD ON OFF

Related Programming Command

TH

Time Date

Softkey that accesses the menu used to set and display the real-time clock.

Key Path

(CONFIG) More 1 of 3 Time Date

Related Programming Command

TIMEDATE

TIMEDATE
ON OFF

Softkey that turns the display of the real-time clock on or off. Pressing **DEFAULT CONFIG** sets **TIMEDATE ON OFF** to ON.

Key Path

CONFIG More Time TIMEDATE
1 of 3 Date ON OFF

CONFIG Print Print TIMEDATE
Config Options ON OFF

Related Programming Command

TIMEDSP

TRACE

Hardkey that accesses the trace softkeys that store and manipulate trace information. Each trace is comprised of a series of data points that form a register where amplitude information is stored. The instrument updates the information for any active trace with each sweep. If two traces are being written to, they are updated on alternating sweeps.

Related Programming Command

none

TRACE
A B C

Softkey that selects the menu used for trace A, trace B, or trace C functions. Press **TRACE A B C** until the letter of the desired trace is underlined.

Key Path

TRACE TRACE
A B C

Related Programming Command

none

TRACE A

As accessed from **(DISPLAY)**

Softkey that activates the trace A portion of the display screen for color editing.

As accessed from either **(RECALL)** or **(SAVE)**.

Softkey that saves trace A data to a floppy disk. To save trace A data press, **Trace -> Disk**, **TRACE A**. **REGISTER #** and **PREFIX=** are displayed on the screen. Use the data keys to enter the desired register number. The message **Saving to :FILENAME** is displayed. Trace A data has now been saved to a disk.

Key Path

| | | | | |
|------------------|---------|--------|--------|---------|
| | Display | Adjust | Edit | |
| (DISPLAY) | Config | Color | Colors | TRACE A |

| | | | |
|-----------------|----------|----------|---------|
| | Recall | Internal | |
| (RECALL) | Internal | -> Trace | TRACE A |

| | | | | |
|---------------|------|--------|---------|---------|
| | Save | More | Trace | |
| (SAVE) | Disk | 1 of 2 | -> Disk | TRACE A |

| | | | |
|---------------|----------|-----------|---------|
| | Save | Trace | |
| (SAVE) | Internal | -> Intrnl | TRACE A |

Related Programming Command

SETC

TRACE B

As accessed from **(DISPLAY)**.

Softkey that activates the trace B portion of the display screen for color editing.

As accessed from either **(RECALL)** or **(SAVE)**.

Softkey that saves trace B data to a floppy disk. To save trace B data press, **Trace -> Disk**, **TRACE B**. **REGISTER #** and **PREFIX=** are displayed on the screen. Use the data keys to enter the desired register number. The message **Saving to :FILENAME** is displayed. Trace B data has now been saved to a disk.

Key Path

| | | | | |
|------------------|---------|--------|--------|---------|
| | Display | Adjust | Edit | |
| (DISPLAY) | Config | Color | Colors | TRACE B |

| | | | |
|-----------------|----------|----------|---------|
| | Recall | Internal | |
| (RECALL) | Internal | -> Trace | TRACE B |

| | | | | |
|---------------|------|--------|---------|---------|
| | Save | More | Trace | |
| (SAVE) | Disk | 1 of 2 | -> Disk | TRACE B |

| | | | |
|---------------|----------|-----------|---------|
| | Save | Trace | |
| (SAVE) | Internal | -> Intrnl | TRACE B |

Related Programming Command

SETC

TRACE C

As accessed from **DISPLAY**.

Softkey that activates the trace C portion of the display screen for color editing.

As accessed from either **RECALL** or **SAVE**.

Softkey that saves trace C data to a floppy disk. To save trace C data press, **Trace -> Disk**, press, **Trace -> Disk**, **TRACE C**. **REGISTER #** and **PREFIX=** are displayed on the screen. Use the data keys to enter the desired register number. The message **Saving to :FILENAME** is displayed. Trace C data has now been saved to a disk.

Key Path

| | | | | |
|----------------|---------|--------|--------|---------|
| | Display | Adjust | Edit | |
| DISPLAY | Config | Color | Colors | TRACE C |

| | | | |
|---------------|----------|----------|---------|
| | Recall | Internal | |
| RECALL | Internal | -> Trace | TRACE C |

| | | | | |
|-------------|------|--------|---------|---------|
| | Save | More | Trace | |
| SAVE | Disk | 1 of 2 | -> Disk | TRACE C |

| | | | |
|-------------|----------|-----------|---------|
| | Save | Trace | |
| SAVE | Internal | -> Intrnl | TRACE C |

Related Programming Command

SETC

Trace -> Disk

Softkey that accesses a menu to select the item to be stored on a floppy disk: the trace to be saved (trace A, trace B, or trace C), or a limit-line table.

Key Path

| | | | | |
|-------------|------|--------|---------|--|
| | Save | More | Trace | |
| SAVE | Disk | 1 of 2 | -> Disk | |

Related Programming Command

none

Trace
-> Intrnl

Softkey that accesses a menu to select the item to be stored in internal memory: the trace to be saved (trace A, trace B, or trace C), or a limit-line table. To save a trace, select the trace to be saved, enter the trace-register number, and press **(ENTER)**. To save a limit-line table press, **LIMIT LINES**, enter the trace-register number, then press **(ENTER)**. Valid trace-register numbers are 0 through the maximum register number. The maximum register number is the number x displayed after **MAX REG # = x** during a save or recall operation. If a screen title is present, it is saved with the trace data. The time and date that the trace was stored is appended to the screen title. If windows are being used, only the trace of the active window will be saved.

Key Path

Save Trace
(SAVE) Internal -> Intrnl

Related Programming Command

SAVET

(TRACK GEN)

Hardkey that accesses a menu that controls the built-in tracking generator.

Related Programming Command

none

TRACKING
PEAK

Softkey that activates a routine to adjust the tracking adjustment for the peak response of the tracking generator.

Note

For tracking peak to function properly, the tracking generator must be connected to the instrument.

Before making a stimulus-response measurement, care must be taken to maximize the tracking adjustment of the tracking generator to ensure maximum available dynamic range.

Key Path

TRACKING
(TRACK GEN) PEAK

Related Programming Command

SRCTKPK

TRIG

Hardkey that accesses a menu that selects the sweep mode and trigger mode. (Also see “Screen Annotation” in Chapter 1 of the User’s Guide.)

Note

With some delayed trigger functions (for example, external or video triggering), the softkey menu is not updated until after the trigger has occurred.

Related Programming Command

TM

TUNE
SLO FAST

Softkey that makes center frequency the active function and, when FAST is underlined, increases the speed of the marker positioning and center frequency tuning functionality of the knob and step keys.

For marker positioning, the knob changes the marker position by four times the normal rate (FAST).

For center frequency, the knob tuning is eight times the normal rate. (FAST)

Key Path

TEST **TUNE**
SLO FAST

Related Programming Command

FASTMRKR

UNDO

Softkey that cancels any changes made in any of the **Edit Colors** functions.

Key Path

DISPLAY **Display** **Adjust** **Special**
Config **Colors** **Colors** **UNDO**

Related Programming Command

none

**VERT
LINES**

Softkey that replaces the standard display screen with a vertical lines. This is one of 18 test patterns that can be used for display-troubleshooting and screen-alignment procedures.

Key Path

(DISPLAY) Display Test More More VERT
Config Patterns 1 of 4 2 of 4 LINES

Related Programming Command

none

**User
Menus**

Softkey that accesses a menu available for your use for user-defined programs and key functions.

Key Path

(MEAS/USER) User
Menus

Related Programming Command

SRCTKPK

**VID AVG
ON OFF**

Softkey that initiates a digital averaging routine that averages displayed signals and noise. This function does not affect the sweep time, bandwidth, or other analog characteristics of the instrument. Annotation on the left side of the screen indicates the current number of sweeps averaged. The default number of sweeps is 100. Increasing the number of sweeps smooths the trace. To turn off the video averaging function, press **VID AVG ON OFF** so that OFF is underlined. The number of sweeps can be entered using the data keys.

Key Path

(BW) More VID AVG
1 of 2 ON OFF

(TRACE) More VID AVG
1 of 3 ON OFF

Related Programming Command

VAVG, CLRAVG

VIDEO

Softkey that activates the trigger condition that allows the next sweep to start if the detected RF envelope voltage rises to a level set by the display line. When VIDEO is pressed, the display line appears on the screen. For example, connect the CAL OUT signal to the instrument input, change the trigger mode to video, and lower the display line. The instrument triggers when the display line reaches the noise floor.

Key Path

TRIG VIDEO

Related Programming Command

TM

VIEW Δ OFF

Softkey that accesses a menu to select which delta from the limit-line table is viewed by the display signal list. Each time this softkey is pressed, it changes sequentially as follows:

- VIEW PK Δ LIM 1
- VIEW PK Δ LIM 2
- VIEW QP Δ LIM 1
- VIEW QP Δ LIM 2
- VIEW AVG Δ LIM 1
- VIEW AVG Δ LIM 2
- VIEW Δ OFF

Key Path

More VIEW Δ
TEST 1 of 3 OFF

Related Programming Command

SIGDLTAVIEW

VIEW A

Softkey that holds and displays the amplitude data that is in the trace A register. The trace A register is not updated as the instrument sweeps. If trace A is deactivated by pressing STORE BLANK A, the stored data can be retrieved by pressing VIEW A.

Key Path

TRACE VIEW A

Related Programming Command

VIEW

VIEW B

Softkey that holds and displays the amplitude data that is in the trace B register. The trace B register is not updated as the instrument sweeps. If trace B is deactivated by pressing **STORE BLANK B**, the stored data can be retrieved by pressing **VIEW B**.

Key Path

TRACE **VIEW B**

Related Programming Command

VIEW

VIEW C

Softkey that holds and displays the amplitude data that is in the trace C register. The trace C register is not updated as the instrument sweeps. If trace C is deactivated by pressing **STORE BLANK C**, the stored data can be retrieved by pressing **VIEW C**.

Key Path

TRACE **VIEW C**

Related Programming Command

VIEW

VIEW CAL ON OFF

Softkey that switches the 300 MHz calibrator signal so that it is routed internally to the input of the instrument or externally to the 300 MHz output of the instrument.

Key Path

VIEW CAL
INPUT **ON OFF**

SETUP **More** **Inst** **VIEW CAL**
1 of 3 **Setup** **Input** **ON OFF**

Related Programming Command

CALSW

VIEW
PK QP AV

Softkey that toggles between the different detection modes, peak (PK), quasi-peak (QP), and average (AV). This function is only active if **QUASI-PEAK** or **AVERAGE** have been selected. **VIEW PK QP AV** does not affect any other settings except the selected detector.

Key Path

TEST More More VIEW
1 of 3 2 of 3 PK QP AV

Related Programming Command

none

VISION
ENHANCE1

Softkey that sets the display screen to vision enhance. The special colors built into vision enhance 1 and 2 accommodate most color deficient vision problems.

Key Path

DISPLAY Display Adjust Special VISION
Config Color Colors ENHANCE1

Related Programming Command

SETC

VISION
ENHANCE2

Softkey that sets the display screen to vision enhance. The special colors built into vision enhance 1 and 2 accommodate most color deficient vision problems.

Key Path

DISPLAY Display Adjust Special VISION
Config Color Colors ENHANCE2

Related Programming Command

SETC

Volts

Softkey that changes the amplitude units to volts.

Key Path

(AMPLITUDE) More Amptd
1 of 3 Units Volts

Related Programming Command

none

Watts

Softkey that changes the amplitude units to watts.

Key Path

(AMPLITUDE) More Amptd
1 of 3 Units Watts

Related Programming Command

none

WHITE DOTS

Softkey that replaces the standard display screen with white dots. This is one of 18 test patterns that can be used for display-troubleshooting and screen-alignment procedures.

Key Path

(DISPLAY) Display Test More WHITE
Config Patterns 1 of 4 DOTS

Related Programming Command

none

WHITE FILL

Softkey that replaces the standard display screen with a white box. This is one of 18 test patterns that can be used for display-troubleshooting and screen-alignment procedures.

Key Path

(DISPLAY) Display Test More More WHITE
Config Patterns 1 of 4 2 of 4 FILL

Related Programming Command

none

WINDOWS
OFF

Softkey that turns off the windows display mode and returns to the normal full-sized display. The state of the last active window will become the instrument state when the windows display is turned off.

Key Path

(CTRL) WINDOWS OFF

Related Programming Command

WINOFF

X FINE
TUNE DAC

Softkey that displays the output of the YTO extra-fine-tune DAC (FM_TUNE) that is on the A7 analog interface assembly. This is a service diagnostic function and is for service use only.

Key Path

(CALIBRATE) More More Service
1 of 3 2 of 3 Diag More 1 ... More 3
X FINE
TUNE DAC

Related Programming Command

none

YTF
DRIVER

For an HP 8546A/HP 85462A only.

Softkey that displays the output of the sample-and-hold circuit in the YTF span divider and driver located on the A7 analog interface assembly. This is a service diagnostic function and is for service use only.

Key Path

(CALIBRATE) More More Service
1 of 3 2 of 3 Diag More 1 ... More 5
YTF
DRIVER

Related Programming Command

none

YTF SPAN

For an HP 8546A/HP 85462A only.

Softkey that displays a trace of the voltage driving the YTF as it sweeps through the displayed span. This is a service diagnostic function and is for service use only.

Key Path

(CALIBRATE) More 1 of 3 More 2 of 3 Service Diag More 1 More 2 YTF SPAN

Related Programming Command

none

YTF TUNE COARSE

For an HP 8546A/HP 85462A only.

Softkey that displays the output produced by the YTF coarse-tune DAC located on the A7 analog interface assembly. This is a service diagnostic function and is for service use only.

Key Path

(CALIBRATE) More 1 of 3 More 2 of 3 Service Diag More 1 ... More 5
YTF TUNE
COARSE

Related Programming Command

none

YTF TUNE FINE

For an HP 8546A/HP 85462A only.

Softkey that displays the output produced by the YTF fine-tune DAC located on the A7 analog interface assembly. This is a service diagnostic function and is for service use only.

Key Path

(CALIBRATE) More 1 of 3 More 2 of 3 Service Diag More 1 ... More 5
YTF TUNE
FINE

Related Programming Command

none

YZ_# Spc
Clear

Softkey that accesses the menu used for selecting the characters Y, Z, underscore (-), #, space, or for clearing the screen title.

Key Access

(CAL), (CONFIG), (DISPLAY), (RECALL), (SAVE), or (SETUP)

Related Programming Command

none

ZERO
SPAN

Softkey that changes the frequency span to zero and turns off marker track if it is on.

Key Path

(SPAN) ZERO
SPAN

Related Programming Command

none

ZONE
CENTER

Softkey that moves the zone markers in frequency without changing the zone span. The zone markers are vertical lines marking the zone on the upper window. They correspond with the frequency range displayed in the lower window. As the zone markers are moved the center frequency of the lower window is changed but the lower window will not be updated unless it is active.

The zone can be moved beyond the frequency range that is being displayed in the upper window. Its movement is limited to the frequency range of the instrument. The zone markers will be displayed at the edges of the upper window when the zone is moved beyond the displayed frequency range.

Key Path

WINDOWS (CTRL) ZONE
CENTER

Related Programming Command

ZMKCNTR

**ZONE
PK LEFT**

Softkey that searches for the next frequency peak outside and to the left of the zone markers on the upper window trace and then moves the zone so that it is centered around the new peak. The zone span is not changed. The center frequency of the lower window changes to reflect the new zone center frequency. The lower window will not be updated until it is made active. If no peak is found the zone will not be moved. A signal must have a 6 dB peak excursion to be identified as a peak signal. The definition of a peak excursion can be changed by selecting **PEAK EXCURSN** while the upper window is active.

Pressing **ZONE PK LEFT** will have no effect if the upper window is in zero span.

Key Path

WINDOWS **(CTRL)** **ZONE
PK LEFT**

Related Programming Command

ZMKPKNL

**ZONE
PK RIGHT**

Softkey that searches for the next frequency peak outside and to the right of the zone markers on the upper window trace and then moves the zone so that it is centered around the new peak. The zone span is not changed. The center frequency of the lower window changes to reflect the new zone center frequency. The lower window will not be updated until it is made active. If no peak is found the zone will not be moved. A signal must have a 6 dB peak excursion to be identified as a peak signal. The definition of a peak excursion can be changing by selecting **PEAK EXCURSN** while the upper window is active.

Pressing **ZONE PK RIGHT** will have no effect if the upper window is in zero span.

Key Path

WINDOWS **(CTRL)** **ZONE
PK RIGHT**

Related Programming Command

ZMKPKNR

**ZONE
SPAN**

Softkey that changes the span of the zone markers without changing the center frequency. The zone markers are vertical lines marking the zone on the upper window. They correspond with the frequency range displayed in the lower window. As the zone markers are moved the span of the lower window is changed but the lower window will not be updated unless it is active.

The zone can be expanded beyond the frequency range that is being displayed in the upper window. Its movement is limited to the frequency range of the instrument. The zone markers will be displayed at the edges of the upper window when the zone is moved beyond the displayed frequency range.

Key Path

WINDOWS (CTRL) **ZONE
SPAN**

Related Programming Command

ZMKSPAN

ZOOM

Hardkey that switches between the split-screen windows display and a full size display of the window that is currently active. Once the ZOOM function is active the (NEXT) key can be used to switch between the two windows while remaining zoomed (full sized).

Related Programming Command

WINZOOM

Error Messages

The instrument can generate various messages that appear on its screen during operation to indicate a problem.

There are three types of messages: hardware error messages (H), user-created error messages (U), and informational messages (M).

- Hardware error messages indicate the instrument hardware is probably broken.
- User-created error messages appear when the instrument is used incorrectly. They are usually generated during remote operation (entering programming commands using either a controller or the external keyboard).
- Informational messages provide information indicating the progress of the instrument within a specific procedure.

The messages are listed in alphabetical order on the following pages; each message is defined, and its type is indicated by an (H), (U), or (M).

ϕ LOCK OFF

Indicates slow YTO tuning. This message may appear if the instrument is using default correction factors. If this message appears constantly, perform the self-calibration routine to try to eliminate this message. ϕ LOCK OFF appears briefly during the self-calibration routine, during instrument preset, or when the frequency value is changed; this is normal and does not indicate a problem. (U) and (H)

ADC-2V FAIL

Indicates a hardware failure. (H)

ADC-GND FAIL

Indicates a hardware failure. (H)

ADC-TIME FAIL

Indicates a hardware failure. (H) and (U)

Bad device type in msus

An attempt has been made to read a disk that is neither LIF nor DOS format or a communication failure between the main processor and the floppy disk subsystem. If the disk in use is LIF or DOS format, try turning the instrument off, wait a few seconds, then turn the instrument on again. If the condition persists, contact your HP representative. (U) (H)

Bad mass storage parameter

May be reported if an attempt is made to read a disk that is neither

LIF nor DOS format. Attempt a catalog operation on the disk or try a different disk. (U)

Bad mass storage volume label

May be reported if an attempt is made to read a disk that is neither LIF nor DOS format. Attempt a catalog operation on the disk or try a different disk. (U)

Bad mass storage volume spec

May be generated if the user removes media while it is being accessed or if a read or write operation is attempted on unformatted media. Try the operation again or try the operation on media you are sure has been appropriately formatted.

Cal harmonic >= 5.7 GHz NOT found *For an HP 8546A/HP 85462A only.*

Indicates that the CAL YTF routine cannot find a harmonic of the 300 MHz calibration signal. If this happens, perform the CAL FREQ and CAL AMP routines, and then perform the CAL YTF routine again. For the HP 8546A, press CAL ALL then perform the CAL YTF routine again.(U) and (H)

CAL: MAIN COIL SENSE FAIL

The instrument could not set up span sensitivity of the main coil. If this message appears, press (FREQUENCY), CENTER FREQ, -37, (Hz), (CALIBRATE), More 1 of 3, More 2 of 3, DEFAULT CAL DATA, and perform the self-calibration routine again. (H)

CAL: NBW 200 Hz notch amp failed

Indicates that the 200 Hz IF bandwidth is not the correct shape for the calibration routine. (H)

CAL: NBW 200 Hz notch failed

Indicates that the 200 Hz IF bandwidth is not the correct shape for the calibration routine. (H)

CAL: NBW 200 Hz width failed

Indicates that the 200 Hz IF bandwidth is not the correct bandwidth for the calibration routine. (H)

CAL: NBW gain failed

Indicates that one of the IF bandwidths is not the correct amplitude for the calibration routine. (H)

CAL: NBW width failed

Indicates that one of the IF bandwidths is not the correct width for the calibration routine. (H)

CAL: PASSCODE NEEDED

Indicates that the function cannot be accessed without the pass code. For the DEFAULT CAL DATA function, the pass code is setting the center frequency of the instrument to -37 Hz. (M)

CAL: RES BW AMPL FAIL

The relative insertion loss of the IF bandwidth is incorrect. This message also sets SRQ 110. (H)

CAL SIGNAL NOT FOUND

Indicates the calibration signal cannot be found. Check that

the instrument input connectors are connected properly. If the calibration signal is connected properly but cannot be found, press **FREQUENCY**, **CENTER FREQ**, **-37**, **Hz**, **CALIBRATE**, **More 1 of 3**, **More 2 of 3**, **DEFAULT CAL DATA**. If the calibration signal still cannot be found, press **FREQUENCY**, **CENTER FREQ**, **-37**, **Hz** and perform the **CAL FREQ** and **CAL AMP** (receiver RF section) or **CAL ALL** (EMI receiver) self-calibration routines. This message also sets SRQ 110. (U) and (H)

CAL: SPAN SENS FAIL

The self-calibration span sensitivity routine failed. This message also sets SRQ 110. (H)

CAL: USING DEFAULT DATA

Indicates that the calibration data is corrupt and the default correction factors are being used. Interruption of the self-calibration routines or an error can cause this problem. (M)

CAL YTF FAILED *For an HP 8546A/HP 85462A only.*

Indicates that the **CAL YTF** routine could not be successfully completed. Perform the self-calibration routines, then perform the **CAL YTF** routine again. (U) and (H)

CAL: ZERO FAIL

The instrument could not set up the tuning sensitivity of the main coil. If this message appears, press **FREQUENCY**, **CENTER FREQ**, **-37**, **Hz**, **CALIBRATE**, **More 1 of 3**, **More 2 of 3**, **DEFAULT CAL DATA**, and perform the self-calibration routines again. (H)

Cannot engage phase lock with current CAL FREQ data

Indicates that the **CAL FREQ** routine needs to be performed before phase locking can be turned on. (U)

Cannot BYPASS Input 1

An attempt was made to execute the **BYPASS** command while the signal path is routed through **INPUT 1** of the RF filter section. Only **INPUT 2** of the RF filter section can be bypassed.

Checkread error

This error may be due to conflicting disk operations invoked from the front-panel keys and the remote I/O port, or it may indicate that the disk is corrupt. After pressing the "HOLD" key, **ENTER**, on the front panel, retry the operation. If the operation fails again, check the disk using the catalog function. (U)

COMMAND ERROR: _ _ _

The specified programming command is not recognized by the instrument. (U)

Configuration Error

This error indicates a serious problem in the ability of the instrument to use the floppy disk drive. Try presetting the instrument. If the condition persists, contact your HP representative. (H)

CONF TEST FAIL

Indicates that the confidence test failed. Perform the self-calibration routines, and then perform the confidence test again. This message also sets SRQ 110. (H) and (U)

Directory not empty

Reported if an attempt is made to purge a non-empty directory. Ensure that all files in any directory have been purged or moved before attempting to purge the directory. (U)

Directory overflow

Reported if the disk directory runs out of room. Change the media. (M)

Drive not found or bad address

An attempt has been made to read a disk that is neither LIF nor DOS format or a communications failure between the main processor and the floppy disk subsystem. If the disk in use is LIF or DOS format, try turning the instrument off, wait a few seconds, then turn the instrument on again. If the condition persists, contact your HP representative. (U) (H)

Duplicate file name

Reported if the file system tries to write data to a file that already exists, but did not exist previously. May be due to changing media just before an operation attempts to create a new file. (U)

Duplicate file name, PROTECT is on

Reported if the user attempts to overwrite a previously existing file with PROTECT status set to ON (the default state). Use a different file name, purge the file, or turn off the PROTECT feature. (U)

End of file or buffer found

Reported if an attempt is made to read or write beyond the current file or directory is made. Also reported if an attempt is made to add files to a directory that is already full. Try using a new disk. (U)

End of rec found, random mode

Reported if an attempt is made to read or write beyond the current record being accessed. Try the operation again. (U)

FAIL: _ _ _

An error was discovered during the power-up check. The 4-digit by 10-digit code indicates the type of error. (H)

File name is undefined

May be reported if the user changes media immediately before a read operation is attempted on a file of a specific name. Ensure that the file exists on the disk by using the catalog feature. (U)

File not currently assigned

May be generated if the user removes media while it is being accessed. Try the operation again. (U)

File open on target device

May be due to conflicting file operations invoked simultaneously from the front-panel keys and the remote I/O port. Attempt the operation again. (U)

File type incompatible

Indicates that the selected file is not a display image file. The file name for a display image file is always preceded by an "i." (U)

FREQ UNCAL

The FREQ UNCAL message appearing constantly, indicates a YTO-tuning error. Perform the **CAL FREQ** (receiver RF section) or **CAL ALL** (EMI receiver) routines. (U) and (H)

Function not available in current Mode

Indicates that the function that you have selected can only be used with the instrument mode. You can use the **MODE** key to select the instrument mode. (U)

HFS disc may be corrupt

This error may be due to conflicting disk operations invoked from the front-panel keys and the remote I/O port, or it may indicate that the disk is corrupt. After pressing the "HOLD" key, **ENTER**, on the front panel, retry the operation. If the operation fails again, check the disk using the catalog function. (U)

Improper destination type

Reported if an attempt is made to append data to a file and the file cannot be extended. Try the operation using another disk. (U)

Improper file name

Reported if a file or directory name is specified that in some manner does not conform to file name conventions: too many characters, illegal character in file name, and so on.

Improper file type

Reported in the event that an operation appropriate for a data file is attempted on a directory. Check the contents of the disk using the catalog function. (U)

Improper value or out of range

Indicates an internal error in computing the amount of data to read from the disk or an invalid parameter. This may indicate corrupt media; try a new disk. If the condition persists, contact your HP representative. (H)

Incorrect unit code in msus

An attempt has been made to read a disk that is neither LIF nor DOS format or a communications failure between the main processor and the floppy disk subsystem. If the disk in use is LIF or DOS format, try turning the instrument off, wait a few seconds, then turn the instrument on again. If the condition persists, contact your HP representative. (U) (H)

Incorrect volume code in msvs

An attempt has been made to read a disk that is neither LIF nor DOS format or a communications failure between the main processor and the floppy disk subsystem. If the disk in use is LIF or DOS format, try turning the instrument off, wait a few seconds, then turn the instrument on again. If the condition persists, contact your HP representative. (U) (H)

Insufficient Memory

Indicates a temporary memory overflow condition. Attempt to free

memory that may have been temporarily allocated by performing the following steps:

1. If there is a disk catalog on the display, exit the catalog.
2. Execute the dispose softkeys under **Dispose User Mem** in the **CONFIG** menu. (U)

INTEGER overflow

Indicates a computation error during disk access. This may indicate corrupt media; try a new disk. If the condition persists, contact your HP representative. (H)

Internal error

Indicates a failure of the floppy disk controller or a failure in communications between the main processor and the floppy disk controller. Try turning the instrument off, wait a few seconds, then turn the instrument on again. If the condition persists, contact your HP representative. (H)

INTERNAL LOCKED

The internal trace and state registers of the instrument have been locked. To unlock the trace or state registers, press **SAVE**, **Save Internal**, **SAV LOCK ON OFF** so that OFF is underlined. (U)

INVALID AMPCOR: FREQ

For the AMPCOR command, the frequency data must be entered in increasing order. See the description for the AMPCOR programming command for more information. (U)

INVALID ENTER FORMAT

The enter format is not valid. See the appropriate programming command description to determine the correct format. (U)

INVALID <file name> NOT FOUND

Indicates that the specified file could not be loaded into internal memory or purged from memory because the file name cannot be found. (U)

INVALID FILENAME _ _ _

Indicates the specified file name is invalid. A file name is invalid if there is no file name specified, if the first letter of the file name is not alphabetic, or if the specified file type does not match the type of file. See the description SAVRCLW or STOR programming commands for more information. (U)

INVALID FILE: NO ROOM

Indicates that there is insufficient space available on the floppy disk to store the data. (U)

INVALID HP-IB ADRS/OPERATION

An HP-IB operation was aborted due to an incorrect address or invalid operation. Check that there is only one controller (the EMI receiver) connected to the printer or plotter. (U)

INVALID HP-IB OPERATION REN TRUE

The HP-IB operation is not allowed. (This is usually caused by trying to print or plot when a controller is on the interface bus with the instrument.) To use the instrument print or plot functions, you must disconnect any other controllers on the HP-IB. If you are using programming commands to print or plot, you can use an HP

BASIC command instead of disconnecting the controller. See the description for the PRINT command for more information. (U)

INVALID ITEM: _ _ _

Indicates an invalid parameter has been used in a programming command. (U)

INVALID KEYLBL: _ _ _

Indicates that the specified key label contains too many characters. A key label is limited to 8 printable characters per label line. (U)

INVALID KEYNAME: _ _ _

The specified key name is not allowed. (The key name may have conflicted with a instrument programming command.) To avoid this problem, use an underscore as the second character in the key name, or avoid beginning the key name with the following pairs of letters: LB, OA, OL, TA, TB, TR, MA, MF, TS, OT, and DR. (U)

INVALID OUTPUT FORMAT

The output format is not valid. See the appropriate programming command description to determine the correct format. (U)

INVALID RANGE: Stop < Start

Indicates that the first trace element specified for a range of trace elements is larger than ending trace element. When specifying a trace range the starting element must be less than the ending element. For example, TRA[2,300] is legal but TRA[300,2] is not. (U)

INVALID REGISTER NUMBER

The specified trace register number is invalid. (U)

INVALID RS-232 ADRS/OPERATION

An RS-232 operation was aborted due to an invalid operation. (U)

INVALID SAVE REG

Data has not been saved in the specified state or trace register, or the data is corrupt. (U)

INVALID SCRMOVE

Indicates the instrument may have a hardware failure. (H)

INVALID START INDEX

Indicates that the first trace element specified for a range of trace elements is not within the trace range of the specified trace. (U)

INVALID STOP INDEX

Indicates that the ending trace element specified for a range of trace elements is not within the trace range of the specified trace. (U)

INVALID TRACE: _ _ _

The specified trace is invalid. (U)

INVALID VALUE PARAMETER: _ _ _

The specified value parameter is invalid. (U)

INVALID WINDOW TYPE: _ _ _

The specified window is invalid. See the description for the TWINDOW programming command. (U)

LOST SIGNAL

This message indicates that an internal hardware connection problem exists. (H)

LO UNLVL

Indicates that the local oscillator in the EMI receiver distribution amplifier is not functioning properly. (H)

Marker Count Reduce SPAN

Indicates the IF bandwidth to span ratio is too small to use the marker count function. Check the span and IF bandwidth settings. (U)

Marker Count Widen RES BW

Indicates that the current IF bandwidth setting is too narrow to use with the marker counter function. The marker counter function can be in narrow IF bandwidths (bandwidths that are less than 1 kHz) with the following procedure:

1. Place the marker on the desired signal.
2. Increase the IF bandwidth to 1 kHz and verify the marker is on the signal peak.
3. If the marker is on the signal peak, the marker count function can be used in either the 1 kHz IF bandwidth or the original narrow IF bandwidth setting. If the marker is not on the signal peak, it should be moved to the signal peak and the marker counter function should not be used with a IF bandwidth setting of less than 1 kHz. (U)

Mass storage hardware failure

Indicates a failure of the floppy disk controller or a failure in communications between the main processor and the floppy disk controller. Try turning the instrument off, wait a few seconds, then turn the instrument on again. If the condition persists, contact your HP representative. (H)

Mass storage medium overflow

Reported when a disk has no more room available to write data. Try a new disk. (U)

Mass storage system error

Indicates a failure of the floppy disk controller or a failure in communications between the main processor and the floppy disk controller. Try turning the instrument off, wait a few seconds, then turn the instrument on again. If the condition persists, contact your HP representative.

Mass storage volume not present

An attempt has been made to read a disk that is neither LIF nor DOS format or a communications failure between the main processor and the floppy disk subsystem. If the disk in use is LIF or DOS format, try turning the instrument off, wait a few seconds, then turn the instrument on again. If the condition persists, contact your HP representative. (U) (H)

MEAS UNCAL

The measurement is uncalibrated. Check the sweep time, span, and bandwidth settings, or press **(AUTO COUPLE)**, **AUTO ALL**. (U)

Medium changed or not in drive

Reported if disk is removed during disk access cycle. Try the operation without removing the disk. (U)

Medium uninitialized

Indicates that a file operation has been attempted on an uninitialized disk, or on a disk that is neither LIF nor DOS format. Be sure that any disk on which file operations are attempted is properly formatted. The format softkeys, in the **CONFIG** menu, may be used to format a disk, but any information on the disk will be erased during the formatting process. (U)

No points defined

Indicates the specified limit line or amplitude correction function cannot be performed because no limit line segments or amplitude correction factors have been defined. (U)

Operation failed on some files

Reported if, during a purge operation on a file specifier that contains wildcards, the number of files actually purged does not match the original number of files found that match the file specifier. Check the disk using the catalog function. (U)

Operation not allowed on open file

May be due to conflicting file operations invoked simultaneously from the front-panel keys and the remote I/O port. Attempt the operation again. (U)

OVEN COLD

Indicates that the EMI receiver has been powered up for less than 5 minutes. (The actual temperature of the precision frequency oven is not measured.) (M)

PARAMETER ERROR: _ _ _

The specified parameter is not recognized by the instrument. See the appropriate programming command description to determine the correct parameters. (U)

PASSCODE NEEDED

Indicates that the function cannot be accessed without the pass code. (U)

Permission denied

Indicates that a file write-operation was attempted on either a read-only file or on a directory. Check the disk using the catalog function and try the operation on an appropriate file again. (U)

Possibly corrupt file

This error may be due to conflicting disk operations invoked from the front-panel keys and the remote I/O port, or it may indicate that the disk is corrupt. After pressing the "HOLD" key, **ENTER**, on the front panel, retry the operation. If the operation fails again, check the disk using the catalog function. (U)

POS-PK FAIL

Indicates the positive-peak detector has failed. (H)

RCVR Limits not allowed in SA mode

This error is encountered when an attempt is made to enable limit-line display, limit-margin display, or limit testing of limits

defined in Receiver mode when the instrument is operating in Signal Analysis mode. To correct the problem, either purge the limits or switch to Receiver mode. (U)

Read data error

This error may be due to conflicting disk operations invoked from the front-panel keys and the remote I/O port, or it may indicate that the disk is corrupt. After pressing the “HOLD” key, (ENTER), on the front panel, retry the operation. If the operation fails again, check the disk using the catalog function. (U)

Record address error

This error may be due to conflicting disk operations invoked from the front-panel keys and the remote I/O port, or it may indicate that the disk is corrupt. After pressing the “HOLD” key, (ENTER), on the front panel, retry the operation. If the operation fails again, check the disk using the catalog function. (U)

Record not found

This error may be due to conflicting disk operations invoked from the front-panel keys and the remote I/O port, or it may indicate that the disk is corrupt. After pressing the “HOLD” key, (ENTER), on the front panel, retry the operation. If the operation fails again, check the disk using the catalog function. (U)

REF UNLOCK

Indicates that the frequency reference is not locked to the external reference input. Check that the 10 MHz REF OUTPUT connector is connected to the EXT REF IN connector, or, when using an external reference, that an external 10 MHz reference source of sufficient amplitude is connected to the EXT REF IN connector. (U) and (H)

Require 1 signal > PEAK EXCURSION above THRESHOLD

Indicates that the N dB PTS routine cannot locate a signal that is high enough to measure. The signal must be greater than the peak excursion above the threshold level to measure. (U)

Require 3 signals > PEAK EXCURSION above THRESHOLD

Indicates that the % AM routine cannot locate three signals that are high enough to measure. The signals must be greater than the peak excursion above the threshold level to measure. (U)

Require 4 signals > PEAK EXCURSION above THRESHOLD

Indicates that the TOI routine cannot locate four signals that are high enough to measure. The signals must be greater than the peak excursion above the threshold level to measure. (U)

Required option not installed

Some instrument functions require that an option be installed in the instrument. See the description for the function in the User’s Guide for more information about which option is required. (U)

RF Filter Section Absent

This message is displayed if the bypass command is executed when the RF filter section is not connected to, or is not communicating with, the receiver RF section. (U) and (H)

RFFS Error: COMMAND

The RF filter section has received a command that it does not recognize. Assure that there is no cable connected to the RF filter

section Service Bus interface. If the condition persists, and there is no cable connected to the RF filter section Service Bus interface, contact your HP representative. (U)

RFFS Error: HARDWARE

The RF filter section has experienced a hardware failure. If the condition persists after presetting the instrument or cycling power, contact your HP representative. (H)

RFFS Error: TIMEOUT

Communication failure between the receiver RF section and the RF filter section. Check power to the RF filter section and check that the AUX interface cable is properly connected between both instruments. (U) (H)

RFFS Service Bus Active

This message appears in the active function area of the receiver RF section display when an external controller communicates with the RF filter section via the RF filter section Service Bus interface. (H)

RF PRESEL ERROR *For an HP 8546A/HP 85462A only.*

Indicates that the preselector peak routine cannot be performed. (H)

RF PRESEL TIMEOUT *For an HP 8546A/HP 85462A only.*

Indicates that the preselector peak routine cannot be performed. (H)

SA Limits not allowed in RCVR mode

This error is encountered when an attempt is made to enable limit-line display, limit-margin display, or limit testing of limits defined in Signal Analysis mode when the instrument is operating in Receiver mode. To correct the problem, either delete the limits or switch to Signal Analysis mode. (U)

SAMPLE FAIL

Indicates the sample detector has failed. (H)

SIGNAL CLIPPED

Indicates that the current FFT measurement sweep resulted in a trace that is above the top graticule line on the display. If this happens, the input trace (trace A) has been "clipped," and the FFT data is not valid. (U)

Signal not found

Indicates the PEAK ZOOM routine did not find a valid signal. (U)

Signals do not fit expected % AM pattern

Indicates that the % AM routine cannot perform the percent AM measurement because the onscreen signals do not have the characteristics of a carrier with two sidebands. (U)

Signals do not fit expected TOI pattern

Indicates that the TOI routine cannot perform the third-order intermodulation measurement because the onscreen signals do not have the characteristics of two signals and two distortion products. (U)

SMPLR UNLCK

Indicates that the sampling oscillator circuitry is not functioning

properly. If this message appears, check that the external frequency reference is correctly connected to the EXT REF INPUT. (U) and (H)

SOFTKEY OVFL

Softkey nesting exceeds the maximum number of levels. (U)

SRQ - - -

The specified service request is active. (M)

STEP GAIN/ATTN FAIL

Indicates the step gain has failed. (H)

TABLE FULL

Indicates the upper or lower table of limit lines contains the maximum number of entries allowed. Additional entries to the table are ignored. (U)

TG SIGNAL NOT FOUND

Indicates the tracking generator output signal cannot be found. For the receiver RF section, check that the TRACKING GENERATOR OUTPUT is connected to the RF INPUT connector with an appropriate cable. For the EMI receiver, check that the cable between the TRACKING GENERATOR OUTPUT and TRACKING GENERATOR is properly connected. (U)

TG UNLVL

This message can indicate the following: that the source power is set higher or lower than the instrument can provide, that the frequency span extends beyond the specified frequency range of the tracking generator, or that the calibration data for the tracking generator is incorrect. (U)

Too many open files

This error may be due to conflicting disk operations invoked from the front-panel keys and the remote I/O port, or it may indicate that the disk is corrupt. After pressing the "HOLD" key, **ENTER**, on the front panel, retry the operation. If the operation fails again, check the disk using the catalog function. (U)

Too many signal with valid N dB points

Indicates the N dB PTS function has located two or more signals that have amplitudes within the specified dB from the signal peak. If this happens, you should decrease the span of the instrument so that only the signal that you want to measure is displayed. (U)

Trace A is not available

Indicates that trace A is in the store-blank mode and cannot be used for limit-line testing. Use **CLEAR WRITE A** or **VIEW A** to change trace A from the store-blank mode to the clear write mode, and then turn on limit-line testing. (U)

Unable to replace file

Reported if an attempt is made to append data to a file and the file cannot be extended. Try the operation using another disk. (U)

USING DEFAULTS self cal needed

Indicates that the current correction factors are the default correction factors and that the self-calibration routines need to be performed. For either an HP 8546A or an HP 85462A, also perform the **CAL YTF** self-calibration routine. (U)

VID-BW FAIL

Indicates the averaging bandwidths have failed. (H)

Wildcard matches > 1 item

An attempt was made to use the wildcard matching character on an operation that requires a specific file name. For example, an attempt to load from a file name that contains a wildcard character. Try the operation using a specific file name. (U)

Wildcards not allowed

An attempt was made to use the wildcard matching character on an operation that requires a specific file name. For example, an attempt to load from a file name that contains a wildcard character. Try the operation using a specific file name. (U)

Write protected

Indicates that a write operation was attempted on a disk that is write protected. Move the write-protect tab on the floppy disk to the unprotected position, reinsert the disk in the disk drive and attempt the operation again. (U)

Nonrecoverable System Errors

Certain situations can create error conditions from which the main processor cannot recover. In the event that the processor detects a nonrecoverable error, the instrument will be initialized, the display will be blanked, and special error messages will be written to the display.

The following is a sample nonrecoverable system error message display.

```
System Error 4, HP 8546A, SN 4
13:18:20 DEC 13, 1993, Rev: 931210
  SR: 0000      PC: 00FFB370      00FF6F1E: 00009300
D0: 00000000   A0: 00FFB238      00FF6F22: 00000000
D1: 00000000   A1: 00FF803E      00FF6F26: 00000000
D2: 00FFB238   A2: 00FF803C      00FF6F2A: 00FF803E
D3: 00FF803E   A3: 00FFB2FE      00FF6F2E: 000031B1
D4: 00008E7D   A4: 00FFB2F4      00FF6F32: 0004065E
D5: 00FF80E8   A5: 00FC6948      00FF6F36: 0004EDE8
D6: 00FFB39A   A6: FFFFFFFE      00FF6F3A: 00FF8000
D7: 00FFB392   A7: 00FF6F1E      00FF6F3E: 00FF88AE
                                00FF6F42: 00FF87E0
                                00FF6F46: 00FFB03C
                                00FF6F4A: 000C9AEA
                                00FF6F4E: 00FF8890
                                00FF6F52: 040800FF
                                00FF6F56: 000900FF
                                00FF6F5A: B23A0000

WARNING: Config Settings Defaulted
        Press COPY to print error report and
        advise your local HP representative
Press PRESET to resume operation
```

When a nonrecoverable error message is displayed, the instrument will only respond to the front-panel COPY and PRESET keys. If you have a printer configured and connected to the instrument, and if no remote controller is currently connected to the I/O port through which the printer is connected, you can generate a hardcopy of the diagnostic part of the error message by pressing the front-panel COPY key.

In order to resume instrument operation following a nonrecoverable system error, press the front-panel PRESET key. The instrument will resume operation from its preset state.

Among the conditions which can contribute to the occurrence of a nonrecoverable system error are:

- Hardware failure of the main processor
- Hardware failure of system memory available to the main processor
- Errors in the primary system control program
- Attempted execution of unsupported system commands

Nonrecoverable system errors may occur when attempting to load an improper file type into the machine. For example, loading a file with an incorrect format into a limit line or amplitude correction table may generate this error.

If nonrecoverable system errors occur regularly, contact your HP representative.

SRQ

Service Requests

This appendix describes the receiver service request (SRQ) capability. A service request is an instrument output that tells the operator or computer that a specific event has taken place in the instrument.

When writing programs, service requests can be used to interrupt the computer program sequence, causing the program to branch to a subroutine. For example, by using service requests, the computer can perform other operations while the receiver is sweeping. When the sweep is completed, the computer can service the receiver by changing the receiver state or reading data from the memory.

Note

Service requests do not work with computers that have an RS-232 interface. Not all service requests are available with some HP-IB computers. Refer to the manuals supplied by your computer's manufacturer.

When making a service request, the receiver places the I/O interface SRQ line true and the receiver displays SRQ with an octal coded number. Setting the SRQ line true announces to the computer that the receiver requires attention. The computer can then command the receiver to send its "status byte." The status byte indicates the type of service request. The status byte is the binary equivalent of the octal SRQ number.

Note

If the instrument display annotation has been blanked, the service request notation will not appear.

A serial polling technique must be used by the computer to test for service requests. The receiver does not respond to parallel polling.

A service request can be cleared from the display by doing an instrument preset.

Status Byte Definition

The status byte sent by the receiver determines the nature of the service request. The meaning of each bit of the status byte is explained in Table A-1.

Table A-1. Status Byte Definition

| Bit | Message | Display Message |
|---------|---|-----------------|
| 0 (LSB) | Overload Detected | SRQ 101 |
| 1 | Unit Key Pressed | SRQ 102 |
| 2 | End of sweep | SRQ 104 |
| 3 | Hardware broken | SRQ 110 |
| 4 | Command complete | SRQ 120 |
| 5 | Illegal spectrum analyzer command | SRQ 140 |
| 6 | Universal HP-IB service request HP-IB RQS bit | - |
| 7 | Unused | - |

The display message is an octal number based on the binary value of the status byte. This octal number always begins with a “1” since this is translated from bit 6, the universal service request bit. The status byte for an illegal receiver command (SRQ 140) is as follows:

| bit number | 7 6 | 5 4 3 | 2 1 0 |
|-------------|-----|-------|-------|
| status byte | 0 1 | 1 0 0 | 0 0 0 |

This displays the octal equivalent of the status byte binary number:
SRQ 140

The octal equivalent is based on the whole binary number: 01100000
(binary) = 140 (octal)

One simple way to determine the octal equivalent of the binary number is to partition the binary number three bits at a time from the least significant bit, and treat each part as a single binary number:

| binary | 0 1 | 1 0 0 | 0 0 0 |
|--------|-----|-------|-------|
| octal | 1 | 4 | 0 |

The decimal equivalent of the octal number is determined as follows:

$$140 \text{ (octal)} = 1 \times (8) + 4 \times (8) + 0 \times (8) = 96 \text{ (decimal)}$$

More than one service request can be sent at the same time. For example, if an illegal receiver command (SRQ 140) and the end of a sweep (SRQ 104) occurred at the same time, SRQ 144 appears on the receiver display, because both bit 5 and bit 2 are set as shown below:

| bit number | 7 6 | 5 4 3 | 2 1 0 |
|-------------|-----|-------|-------------|
| status byte | 0 1 | 1 0 0 | 1 0 0 |
| octal value | 1 | 4 | 4 = SRQ 144 |

Service Request Activating Commands

With the exceptions of SRQ 101, SRQ 140, and SRQ 110, service requests can only be activated from a computer. (SRQ 101, SRQ 140, and SRQ 110 are activated at instrument preset.) Your programmer's guide describes service request activating commands under RQS and SRQ.

Index

- 0** 0-2.9 Gz BAND 0, 4-5, 4-25
- 1** 10 MHz reference DAC setting, 4-33
 - +10V REF DETECTOR, 4-2, 4-9
 - 10V REF DETECTOR, 4-9
 - 120 kHz EMI BW, 4-10
 - 150 kHz - 30 MHz, 4-10
- 2** 200 Hz EMI BW, 4-11
 - 200 MHz - 1 GHz, 4-11
 - 2.75-6.5 BAND 1, 4-6, 4-25
 - 2v REF DETECTOR, 4-2, 4-6
- 3** 30 MHz - 300 MHz, 4-9
 - 3 dB POINTS, 4-7
 - 3rd ORD MEAS, 4-7
- 6** 6 dB POINTS, 4-8
- 9** 99% PWR BW, 4-10
 - 9 kHz - 150 kHz, 4-8
 - 9 kHz EMI BW, 4-8
- A** ABCDEF, 4-13
 - ABORT, 4-13
 - A -> C, 4-12
 - ac coupling, 4-51
 - ACTIVE, 4-13
 - active function clearing, 4-93
 - addressing printer, 4-148
 - address of plotter, 4-137
 - ADD TO LIST, 4-13
 - Adjust Color, 4-14
 - ADVISORY, 4-14
 - A <-> B, 4-11
 - ALC INT EXT, 4-14
 - alpha characters, 4-13, 4-90, 4-190, 4-206
 - % AM, 4-4
 - A-B -> A ON OFF, 4-12
 - AMPLITUDE, 4-15
 - amplitude accuracy, 4-50
 - amplitude correction factors
 - edit done, 4-70

- select amplitude, 4-168
- select frequency, 4-170
- select point, 4-172
- amplitude demodulation, 4-61
- amplitude menus, 4-15
- amplitude modulation, 4-4
- amplitude scale, 4-167
- amplitude units, 4-16
 - dBm, 4-53
 - dB μ V, 4-54
 - dBmV, 4-54
 - Volts, 4-203
 - Watts, 4-203
- AMPL SCL LOG LIN, 4-15
- Amptd Units, 4-16
- ANNOTATN, 4-16
- ANNOTATN ON OFF, 4-16
- ANTENNA -> DISK, 4-17
- Antenna Factors, 4-17
- ANTENNA ON OFF, 4-17
- Antenna Units, 4-18
- APND CAT ITEM, 4-18
- ATTEN AUTO MAN, 4-18
- attenuation coupling, 4-19
- attenuator-error factors, 4-176
- AUTO ALL, 4-19
- AUTO CAL ON OFF, 4-19
- AUTO COUPLE, 4-20
- AUTOEXEC ON OFF, 4-21
- AUTO-MEASURE, 4-20
- AUTO RANGE, 4-21
- AUTORANG ON OFF, 4-21
- Aux Conn Control, 4-22
- AUX CTRL, 4-22
- auxiliary connector input, 4-65
- auxiliary interface
 - connector, 4-22
 - control line A, 4-44
 - control line B, 4-44
 - control line C, 4-44
 - control line D, 4-45
- available memory, 4-35
- AV DWELL TIME, 4-22
- AVERAGE, 4-23
- average video bandwidth coupling, 4-19
- AVG BW AUTO MAN, 4-23
- AV/IF BW RATIO, 4-23

B BACKGRND, 4-24
Band Lock, 4-25
band locking, 4-28
bandwidth functions, 4-29
BAUD RATE, 4-25
B -> C, 4-24
B <-> C, 4-24
bias-current DAC adjustment, 4-33
binary, A-2
BLACK FILL, 4-26
BLACK LEVEL, 4-26
BLANK A, 4-26
BLANK B, 4-27
BLANK C, 4-27
BLUE, 4-27
BLUE FILL, 4-27
B-DL -> B, 4-24
BND LOCK ON OFF, 4-28
BRIGHT, 4-28
BW, 4-29

C CABLE -> DISK, 4-29
Cable Factors, 4-29
CABLE ON OFF, 4-30
CAL 85422, 4-30
CAL 85462, 4-30
CAL ALL, 4-30
CAL AMP, 4-31
Cal At Time, 4-31
CAL CHECK, 4-31
CAL FETCH, 4-31
CAL FREQ, 4-32
CALIBRATE, 4-32
calibration
 attenuator-error factors, 4-176
CAL INPUT 1, 4-32
CAL INPUT 2, 4-32
CAL MXR, 4-2, 4-33
CAL STORE, 4-33
CAL TIMEBASE, 4-2, 4-33
CAL TRK GEN, 4-34
CAL YTF, 4-34
CATALOG ALL, 4-34
CATALOG DISK, 4-35
Catalog Internal, 4-35
CATALOG PREFIX, 4-37
CATALOG REGISTER, 4-37
CATALOG VARIABLES, 4-38
CENTER FREQ, 4-38
center frequency, 4-38
 window zone, 4-206
center-frequency step size, 4-38
CF STEP AUTO MAN, 4-38
change prefix

- edit done, 4-70
- Change Prefix, 4-39
- Change Title, 4-40
- characters, 4-13, 4-90, 4-190, 4-206
- CLEAR ANNOTATN, 4-41
- clearing a service request, A-1
- clearing the active function, 4-93
- CLEAR MARK, 4-41
- CLEAR WRITE A, 4-41
- CLEAR WRITE B, 4-42
- CLEAR WRITE C, 4-43
- CLR ALL MARKS, 4-43
- CNTL A 0 1, 4-44
- CNTL B 0 1, 4-44
- CNTL C 0 1, 4-44
- CNTL D 0 1, 4-45
- CNT RES AUTO MAN, 4-51
- COARSE TUNE DAC, 4-2, 4-45
- COLOR BARS, 4-45
- COLOR MONOCHRM, 4-46
- command complete, A-1
- commands
 - front panel execution, 4-78
- COMPLMNT MARKS, 4-46
- CONFIG, 4-46
- CONFIG DONE, 4-47
- configuration
 - plotter, 4-137
 - printer, 4-148
- connector, auxiliary interface, 4-22
- continuous sweep, 4-190
- control line A
 - auxiliary interface, 4-44
- control line B
 - auxiliary interface, 4-44
- control line C
 - auxiliary interface, 4-44
- control line D
 - auxiliary interface, 4-45
- COPY, 4-47
- COPY DEV PRNT PLT, 4-49
- COPY SCREEN, 4-50
- correction factors, 4-50
 - data display, 4-65
 - default, 4-54
 - self-calibration, 4-31
 - storing, 4-33
- Correctn Factors, 4-50
- CORRECTN ON OFF, 4-51
- CORRECT ON OFF, 4-50
- COUPLE AC DC, 4-51
- coupled functions menu, 4-20
- coupled sweep time, 4-192
- coupling
 - ac or dc, 4-51

- all functions, 4-19
- creating new programs, 4-129

- D** DAC
 - bias current adjustment, 4-33
 - extra fine-tune, 4-204
 - fine tune, 4-82
 - mixer bias, 4-125
 - sweep time, 4-191
 - YTF coarse tune, 4-205
 - YTF fine-tune, 4-205
- DACS, 4-2, 4-53
- data recall, 4-154
- DATEMODE MDY DMY, 4-53
- dBm, 4-53
- dB μ V, 4-54
- dBmV, 4-54
- dc coupling, 4-51
- deactivating the active function, 4-93
- DEFAULT CAL DATA, 4-54
- DEFAULT COLORS, 4-55
- DEFAULT CONFIG, 4-55
- Define List, 4-56
- Define Report, 4-56
- DEFINE USER KEY, 4-56
- DELETE ALL SIGS, 4-57
- DELETE FACTORS, 4-57
- DELETE FILE, 4-57
- DELETE LIMIT, 4-59
- DELETE MARKED, 4-59
- DELETE POINT, 4-59
- DELETE SEGMENT, 4-60
- DELETE SIGNAL, 4-60
- Delete Signals, 4-61
- delta marker, 4-115
- DELTA MEAS, 4-61
- DEMOD AM FM, 4-61
- DEMOD ON OFF, 4-62
- demodulation
 - AM, 4-61
 - dwell time, 4-68
 - FM, 4-61
 - FM gain, 4-84
 - FM offset, 4-84
 - FM span, 4-85
 - on and off, 4-62
 - speaker on off, 4-185
 - squelch, 4-185
- DESKJET, 4-62
- DESKJET 500, 4-62
- DESKJET 500C, 4-63
- DESKJET 550C, 4-63
- detection mode
 - positive peak, 4-64

- sample, 4-64
- detector
 - quasi peak, 4-152
- DETECTOR PK QP AV, 4-63
- DETECTOR SMP PK, 4-64
- disable peak detector reset, 4-67
- Disk Config, 4-64
- display
 - two windows, 4-52
- DISPLAY, 4-64
- DISPLAY CAL DATA, 4-2, 4-65
- DISPLAY CNTL I, 4-65
- Display Config, 4-66
- DISPLAY -> DISK, 4-65
- display line, 4-67
- Display Sys Data, 4-2, 4-66
- display zone
 - change span, 4-208
 - find left peak, 4-207
 - find right peak, 4-207
 - move center, 4-206
- DISPOSE USER KEY, 4-66
- Dispose User Mem, 4-66
- DLP
 - editor, 4-76
- DLP editor function
 - appending, 4-18
- double display, 4-52
- DROOP, 4-2, 4-67
- DSP LINE ON OFF, 4-67
- DWELL TIME, 4-68

E

- EDIT ANNOTATN, 4-68
- EDIT ANTENNA, 4-68
- EDIT CABLE, 4-69
- EDIT CAT ITEM, 4-69
- Edit Colors, 4-69
- EDIT DONE, 4-70
- EDIT FLATNESS, 4-2, 4-71
- editing
 - DLPs, 4-76
- EDIT LAST, 4-71
- Edit Limit, 4-72
- EDIT LIMIT, 4-72
- EDIT LIST, 4-72
- EDIT LOWER, 4-73
- EDIT MID/DELT, 4-73
- Editor, 4-76
- EDIT OTHER, 4-74
- EDIT PA FLATNESS, 4-2, 4-74
- EDIT UP/LOW, 4-74
- EDIT UPPER, 4-75
- EDIT UPR LWR, 4-75
- EMI bandwidth

- 120 kHz, 4-10
- 200 Hz, 4-11
- 9 kHz, 4-8
- EMI RECEIVER, 4-76
- end of sweep, A-1
- EPSON MX, 4-77
- ERASE STATEALL, 4-77
- ERASE TRACEALL, 4-77
- erase user programs and variables, 4-66
- error messages, 5-1
- ERRORS, 4-77
- errors, non recoverable, 5-14
- exchange trace A and B, 4-11
- exchange trace B and C, 4-24
- execute a command
 - front panel, 4-78
- EXECUTE TITLE, 4-2, 4-78
- EXIT, 4-78
- EXIT CATALOG, 4-78
- EXIT EDIT, 4-79
- EXIT GRAPH, 4-79
- EXIT LAST CAL, 4-80
- EXIT MEASURE, 4-80
- EXIT SHOW, 4-80
- expanding a window, 4-208
- EXTERNAL, 4-81
- external/internal leveling, 4-14
- EXTERNAL PREAMPG, 4-81

F

- fast Fourier transform, 4-82
- fatal errors, 5-14
- FFT MEAS, 4-82
- FINE TUNE DAC, 4-2, 4-82, 4-204
- fixed, limit line type, 4-105
- FLAT, 4-83
- flatness
 - factory defaults, 4-95
- flatness correction constants, 4-71, 4-83
- Flatness Data, 4-2, 4-83
- floppy disk
 - delete file, 4-57
- FM COIL DRIVE, 4-2, 4-84
- FM GAIN, 4-2, 4-84
- FM OFFSET, 4-2, 4-84
- FM SPAN, 4-2, 4-85
- format date, 4-53
- FORMAT DOS DISK, 4-85
- FORMAT LIF DISK, 4-85
- FREE RUN, 4-86
- FREQ DIAG, 4-2, 4-86
- FREQ OFFSET, 4-87
- FREQ SCL LOG LIN, 4-87
- FREQ STEP, 4-88
- frequency

- stop, 4-188
- FREQUENCY, 4-88
- frequency demodulation, 4-61
- frequency, improving accuracy, 4-111
- frequency offset, 4-87
- frequency span, 4-184
 - changing to full span, 4-89
- front panel execution of programming commands, 4-78
- FRQ DISC NORM OFF, 4-2, 4-86
- FRQ SCAN ON OFF, 4-89
- FULL SPAN, 4-89
- FULL WHITE, 4-89
- function coupling, 4-19

G

- Gauss, 4-90
- GEO DST TEST, 4-90
- GHIJKL, 4-90
- GND REF DETECTOR, 4-2, 4-90
- GRATICUL, 4-91
- GRAT ON OFF, 4-91
- GRAY SCALE, 4-91
- GREEN, 4-92
- GREEN FILL, 4-92
- GRID, 4-92

H

- HALF FILL, 4-93
- hardware broken, A-1
- hardware error messages, 5-1
- harmonic band menu, 4-25
- harmonic band slope and offset adjust, 4-34
- harmonic lock, 4-28
- highest peak
 - finding next, 4-130
- highest signal peak, 4-184
- HI VOLT TEST, 4-93
- HOLD, 4-93
- HORIZ LINES, 4-93
- HP Paintjet, 4-135
- HSL RGB, 4-94
- HUE, 4-94

I

- IDNUM, 4-2, 4-94
- IF BW AUTO MAN, 4-95
- IF GAINS, 4-2, 4-95
- illegal spectrum analyzer command, A-1
- informational messages, 5-1
- INIT FLT, 4-2, 4-95
- INPT LOCK ON OFF, 4-96
- Input, 4-96
- INPUT, 4-96
- INPUT 1, 4-96
- INPUT 1 9k-50M, 4-97
- INPUT 1 PREAMP, 4-97
- INPUT 2, 4-97

- INPUT 2 1-6.5G, 4-98
- INPUT 2 20M-2.9G, 4-97
- INPUT 2 BYPASS, 4-98
- INPUT 2 PREAMP, 4-98
- input and output
 - auxiliary control, 4-22
- input attenuation control, 4-18
- input impedance, 4-99
- INPUT Z 50Ω 75Ω, 4-99
- instrument preset, 4-142
- Inst Setup, 4-99
- INTENSITY, 4-99
- intermediate frequency bandwidth coupling, 4-19
- internal/external leveling, 4-14
- internal memory, 4-35
 - cataloging functions, 4-35
 - catalog variables, 4-38
 - delete file, 4-57
 - erase user programs and variables, 4-66
 - program and variable cataloging, 4-34
 - saving to, 4-197
 - state and trace register status, 4-37
- INTERNAL -> STATE, 4-100
- Internal -> Trace, 4-100

K key menus, 3-1, 3-2-21

L LASERJET, 4-101

- LASERJET II, 4-101
- LASERJET III, 4-101
- Last Cal, 4-101
- Last Hrd Key Menu, 4-102
- LAST SPAN, 4-102
- Limit 1, 4-102
- LIMIT 1 ON OFF, 4-103
- Limit 2, 4-103
- LIMIT 2 ON OFF, 4-103
- LIMIT LINE 1, 4-104
- limit lines
 - delete point, 4-59
 - delete segment, 4-60
 - displaying, 4-108
 - edit lower table, 4-73
 - edit mid/delta amplitude, 4-73
 - edit table, 4-72
 - edit upper and lower tables, 4-74, 4-75
 - edit upper table, 4-75
 - fixed and relative, 4-105
 - flat type, 4-83
 - point, 4-138
 - purge, 4-150
 - recall table, 4-156
 - save table, 4-164
 - select amplitude, 4-168

- select frequency, 4-170
- select frequency or time, 4-106
- select lower amplitude, 4-171
- select middle amplitude, 4-171
- select segment, 4-173
- select type, 4-174
- select upper amplitude, 4-175
- slope type, 4-181
- testing, 4-109
- Limit Lines, 4-104
- LIMIT LINES, 4-104
- LIMITS -> DISK, 4-105
- LIMITS FIX REL, 4-105
- LIMITS FRQ TIME, 4-106
- LINE, 4-107
- LINEARITY, 4-107
- LINEARITY CHECK, 4-107
- linear scale, 4-167
- linear sweep, 4-190
- LIN ON OFF, 4-107
- LIST -> DISK, 4-108
- LIST ON OFF, 4-108
- LMT DISP Y N AUTO, 4-108
- LMT TEST ON OFF, 4-109
- LOAD FILE, 4-109
- (LOCAL), 4-46, 4-110
- local operation, 4-46, 4-110
- lock harmonic band, 4-28
- lock internal state and trace registers, 4-167
- logarithmic sweep, 4-190
- LOGF SPD, 4-111
- LOG ON OFF, 4-111
- log scale, 4-167
- lower limit line
 - editing, 4-73
- LUMIN-OSITY, 4-111

M

- MAIN COIL DR, 4-2, 4-112
- MAIN SPAN, 4-2, 4-112
- MAN TRK ADJUST, 4-112
- manual tracking adjustment, 4-112
- MARGIN 1 ON OFF, 4-113
- MARGIN 2 ON OFF, 4-113
- MARK ALL DUPLICAT, 4-113
- MARK ALL SIGNALS, 4-114
- marker
 - menu of controls, 4-126
 - selection, 4-168
 - trace selection, 4-127
- MARKER, 4-115
- MARKER 1 ON OFF, 4-118
- MARKER 2 ON OFF, 4-118
- MARKER 3 ON OFF, 4-119
- MARKER 4 ON OFF, 4-119

- MARKER ALL OFF, 4-119
- MARKER AMPTD, 4-120
- MARKER ->CF, 4-116
- MARKER ->CF STEP, 4-116
- marker counter, 4-125
- MARKER FUNCTION, 4-120
- MARKER ->MINIMUM, 4-117
- marker noise, 4-126
- MARKER NORMAL, 4-120
- marker pause, 4-126
 - dwel time, 4-68
- MARKER ->PK-PK, 4-117
- marker readout modes, 4-127
- MARKER ->REF LVL, 4-117
- MARKERS, 4-121
- MARKER ->START, 4-118
- MARKER ->STOP, 4-118
- marker tracking, 4-128
- MARKER TUNE SPN, 4-121
- MARKER Δ , 4-115
- MARKER Δ SPAN, 4-116
- MARK LWR DUPLICAT, 4-114
- MARK SIGNAL, 4-114
- MARK TO END, 4-114
- MAX HOLD A, 4-122
- MAX HOLD B, 4-122
- maximum mixer level, 4-122
- MAX MXR LVL, 4-122
- MEAS SNG CONT, 4-123
- MEAS STEPPED, 4-123
- MEASURE AT MKR, 4-124
- Measure Detector, 4-124
- MEAS/USER, 4-123
- MEM LOCKED, 4-124, 4-167
- memory
 - amount available, 4-35
- menus, 3-1
- μ A/m, 4-5
- μ V/m, 4-5
- mid/delta limit line
 - editing amplitude, 4-73
- MIN HOLD C, 4-125
- minimizing scan time, 4-111
- minimum to marker, 4-117
- 10V REF DETECTOR, 4-2
- MIXER BIAS DAC, 4-2, 4-125
- mixer input level maximum, 4-122
- MK COUNT ON OFF, 4-125
- MK NOISE ON OFF, 4-126
- MK PAUSE ON OFF, 4-126
- MKR, 4-126
- MKR ->, 4-127
- MK READ F T I P, 4-127
- MK TRACE AUTO ABC, 4-127
- MK TRACK ON OFF, 4-128

MNOPQR, 4-128
MODE, 4-129
MONO-CHROME, 4-129
move trace A into C, 4-12
multipen plotter, 4-48

N NEW EDIT, 4-129
NEXT, 4-130
NEXT PAGE, 4-130
NEXT PEAK, 4-130
NEXT PK LEFT, 4-130
NEXT PK RIGHT, 4-131
NO CONVERSN, 4-131
non recoverable errors, 5-14
normal marker, 4-120
NORMLIZE ON OFF, 4-132
NORMLIZE POSITION, 4-132
No User Menus, 4-131

O octal to binary, A-2
ON/OFF, 4-132
operation
 local, 4-110
OPTICAL FILTER, 4-133
optimizing frequency accuracy, 4-111
OTHER -> DISK, 4-133
Other Factors, 4-133
OTHER ON OFF, 4-134
OUTPUT, 4-134
output power, 4-186
OUTPUT REPORT, 4-134
output screen data, 4-47
OVLN ON OFF, 4-134

P PAINTJET PRINTER, 4-135
PALETTE BARS, 4-135
parallel polling, A-1
pass code, 4-54
peak
 next, 4-130
 next left, 4-130
 next right, 4-131
peak detection mode
 positive/negative, 4-64
PEAK EXCURSN, 4-135
Peak Menu, 4-136
peak response routine, 4-197
peak search
 outside of the zone, 4-207
PEAK SEARCH, 4-136
peak to peak measurement, 4-117
percent amplitude modulation, 4-4
phase lock on/off, 4-4
 ϕ LOCK ON OFF, 4-2, 4-4

- PK DWELL TIME, 4-136
- PK-PK MEAS, 4-137
- Plot Config, 4-137
- PLOTTER ADDRESS, 4-137
- plotter configuration, 4-46
- plotting, 4-47, 4-49
- PLT MENU ON OFF, 4-138
- PLTS/PG 1 2 4, 4-138
- POINT, 4-138
- point deletion, 4-59
- positive peak detection mode, 4-64
- POWER ON IP LAST, 4-139
- power-on state of spectrum analyzer, 4-139
- PREAMP, 4-140
- preamplifier gain, 4-81
- PREAMP ON OFF, 4-140
- predetermined correction factors, 4-54
- prefix
 - catalog of, 4-37
 - entry, 4-39
 - selection, 4-172
- PRESEL DAC, 4-2, 4-141
- PRESEL DEFAULT, 4-141
- preselector default, 4-141
- preselector peak, 4-141
- PRESEL PEAK, 4-141
- PRESET, 4-142
- preset conditions
 - receiver, 4-142
 - signal analysis, 4-143
- preset conditions receiver mode, 4-142
- preset conditions signal analysis mode, 4-143
- PRESET RECEIVER, 4-145
- PRESET SPECTRUM, 4-146
- Print Config, 4-148
- printer
 - HP Paintjet, 4-47
- PRINTER ADDRESS, 4-148
- printer configuration, 4-46
- PRINTER SETUP, 4-148
- Printer Type, 4-149
- printing, 4-47, 4-49
 - HP PaintJet, 4-135
- print menu, 4-150
- Print Options, 4-148
- PRN/PG 1 2, 4-149
- program cataloging, 4-34
- program (DLP) editor, 4-76
- program editing and creating, 4-76
- programming command
 - front panel execution, 4-78
- PROTECT ON OFF, 4-149
- PRT MENU ON OFF, 4-150
- pTesla, 4-150
- PURGE LIMITS, 4-150

PWR SWP ON OFF, 4-151

Q QP/AVG 10X OFF, 4-152
QP DET ON OFF, 4-3, 4-152
QPD OFFSET, 4-3, 4-153
QPD RST ON OFF, 4-3, 4-153
QP DWELL TIME, 4-152
QP GAIN ON OFF, 4-3, 4-153
quasi-peak
 detector, 4-152
QUASI-PEAK, 4-154
QUIETJET, 4-154

R real-time clock, 4-193
 set date, 4-176
 set time, 4-177
 time and date display, 4-193
RECALL, 4-154
RECALL ANTENNA, 4-154
RECALL CABLE, 4-155
RECALL COLORS, 4-155
Recall Disk, 4-155
recalling a trace from internal memory, 4-100
Recall Internal, 4-156
RECALL LIMITS, 4-156
RECALL LIST, 4-156
RECALL OTHER, 4-157
RECALL SETUP, 4-157
RECALL TRACE, 4-157
RECEIVER ADDRESS, 4-158
receiver auto-coupled sweep time, 4-191
RED, 4-158
RED FILL, 4-158
reference detector
 2V, 4-6
 ground, 4-90
reference level, 4-158
reference level offset, 4-159
REF LVL, 4-158
REF LVL OFFSET, 4-159
relative, limit line type, 4-105
REMEAS ALL SIGS, 4-159
REMEAS MARKED, 4-160
REMEAS SIGNAL, 4-160
Re-measure, 4-160
remote command
 front panel execution, 4-78
remote operation, 4-46
RESOLUTN LOW HIGH, 4-161
RESTART, 4-161

S sample detection mode, 4-64
 SATUR-ATION, 4-161
 SAVE, 4-162
 SAVE ANTENNA, 4-162
 SAVE CABLE, 4-162
 SAVE COLORS, 4-163
 save current state
 state register, 4-187
 saved analyzer state, 4-100
 Save Disk, 4-163
 SAVE EDIT, 4-163
 Save Internal, 4-164
 SAVE LIMITS, 4-164
 SAVE LIN GRAPH, 4-164
 SAVE LIST, 4-165
 SAVE LOG GRAPH, 4-165
 SAVE OTHER, 4-166
 Save/Rcl\ List, 4-166
 SAVE SETUP, 4-166
 saving to internal memory, 4-197
 SAV LOCK ON OFF, 4-167
 SCALE LOG LIN, 4-167
 scan time, minimizing, 4-111
 screen annotation
 on or off, 4-16
 screen characters, 4-90, 4-128, 4-190, 4-206
 screen data output, 4-47
 screen graticule, 4-91
 screen title, 4-40
 characters, 4-13
 segment deletion, 4-60
 SELECT, 4-168
 SELECT 1 2 3 4, 4-168
 SELECT AMPLITUD, 4-168
 Select Axis, 4-169
 SELECT DELT AMP, 4-169
 SELECT FREQ, 4-170
 SELECT FRM LIST, 4-171
 SELECT LWR AMPL, 4-171
 SELECT MID AMPL, 4-171
 SELECT POINT, 4-172
 SELECT PREFIX, 4-172
 SELECT SEGMENT, 4-173
 SELECT TYPE, 4-174
 SELECT UPR AMPL, 4-175
 Selectv Mark, 4-175
 self-calibration routines
 correction factors, 4-31
 tracking generator, 4-34
 serial polling, A-1
 Service Cal, 4-2, 4-176
 Service Diag, 4-2, 4-176
 service functions, 4-2
 Service Cal, 4-2
 Service Diag, 4-2

- service request, A-1
 - clearing, A-1
- SET ATTN ERROR, 4-2, 4-176
- SET DATE, 4-176
- SET TIME, 4-177
- SETTINGS ON OFF, 4-177
- setup
 - printer, 4-148
- SETUP, 4-177
- SETUP -> DISK, 4-178
- SHOW COR ON OFF, 4-179
- SHOW DET PK QP AV, 4-179
- SHOW MKR ON OFF, 4-179
- SHOW SETUP, 4-180
- SHOW $\Delta 1$ PK QP AV, 4-178
- SHOW $\Delta 2$ PK QP AV, 4-178
- SHW INST CONFIG, 4-180
- SIG LIST ON OFF, 4-180
- SIGNAL ANALYSIS, 4-181
- Signal Marking, 4-181
- signal peak
 - highest, 4-184
- SINGLE, 4-181
- single sweep, 4-190
- SLOPE, 4-181
- softkey locations, 3-1
- SOFTKEYS, 4-182
- SORT BY AVG AMP, 4-182
- SORT BY DLTA LIM, 4-183
- SORT BY FREQ, 4-182
- SORT BY PK AMP, 4-183
- SORT BY QP AMP, 4-183
- Sort Signals, 4-183
- source power, 4-186
- space
 - character, 4-206
- span
 - 0 Hz, 4-206
 - LAST SPAN, 4-102
 - window zone, 4-208
- SPAN, 4-184
- SPAN ZOOM, 4-184
- SPEAKER ON OFF, 4-185
- Special Colors, 4-185
- spectrum analyzer configuration
 - default, 4-55
- spectrum analyzer state recalled, 4-139
- split screen, 4-52
- SQUELCH, 4-185
- SRC ATN MAN AUTO, 4-186
- SRC PWR OFFSET, 4-186
- SRC PWR ON OFF, 4-186
- SRC PWR STP SIZE, 4-187
- SRQ, A-1
- standard timebase, 4-33

start and stop frequencies, 4-116
 START FREQ, 4-187
 STATE -> INTRNL, 4-187
 state of spectrum analyzer at power on, 4-139
 state registers
 locking, 4-167
 STATUS, 4-188
 status byte, A-1
 status byte definition, A-1
 STEP LOG LIN, 4-188
 step size, center frequency, 4-38
 step-size coupling, 4-19
 stimulus response mode, 4-191
 STOP, 4-188
 STOP FREQ, 4-188
 store correction factors, 4-33
 STORE FLATNESS, 4-2, 4-189
 STOR PWR ON UNITS, 4-2, 4-189
 STP GAIN ZERO, 4-3, 4-189
 STUVWX, 4-190
 subtract display line from trace B, 4-24
 subtract trace B from A, 4-12
 SWEEP, 4-190
 sweep control
 continuous, 4-190
 single, 4-190
 SWEEP CONT SGL, 4-190
 SWEEP LOG LIN, 4-190
 SWEEP RAMP, 4-3, 4-191
 sweep time, 4-192
 sweep time coupling, 4-19
 SWEEP TIME DAC, 4-3, 4-191
 switch trace A and B, 4-11
 SWP CPLG SR RECV, 4-191
 SWP TIME AUTO MAN, 4-192

T TEST, 4-192
 Test Patterns, 4-192
 THINKJET, 4-193
 ThinkJet Printer mode switch settings, 4-47
 THRESHLD ON OFF, 4-193
 threshold line, 4-193
 Time Date, 4-193
 TIMEDATE ON OFF, 4-194
 trace
 A -> C, 4-12
 A <-> B, 4-11
 A-B -> A, 4-12
 blank trace A, 4-26
 blank trace B, 4-27
 blank trace C, 4-27
 B-DL -> B, 4-24
 clear write trace A, 4-41
 clear write trace B, 4-42

- clear write trace C, 4-43
- move trace B into C, 4-24
- view mode, 4-200
- TRACE, 4-194
- trace A
 - maximum hold, 4-122
- TRACE A, 4-195
- TRACE A B C, 4-194
- trace B
 - maximum hold, 4-122
- TRACE B, 4-195
- TRACE C, 4-196
- Trace -> Disk, 4-196
- Trace -> Intrnl, 4-197
- trace registers
 - locking, 4-167
- TRACK GEN, 4-197
- tracking generator
 - frequency adjustment, 4-112
 - internal/external leveling, 4-14
 - output power, 4-186
 - peak response, 4-197
 - power sweep, 4-151
 - power sweep range, 4-187
 - self-calibration, 4-34
 - source attenuator, 4-186
 - source power offset, 4-186, 4-187
 - source power step size, 4-187
- TRACKING PEAK, 4-197
- TRIG, 4-198
- trigger, 4-198
 - external, 4-81
 - free run, 4-86
 - line, 4-107
 - video, 4-200
- TUNE SLO FAST, 4-198
- turning off markers, 4-119
- turning off windows display, 4-204
- two display windows, 4-52
- type of limit line, 4-174

U

- underscore
 - character, 4-206
- UNDO, 4-198
- unit key pressed, A-1
- units, amplitude, 4-16
- universal HP-IB service request, A-1
- upper and lower limit lines
 - editing, 4-74
- user-created error messages, 5-1
- User Menus, 4-199

- V** variable cataloging, 4-34
- VERT LINES, 4-199
- VID AVG ON OFF, 4-199
- VIDEO, 4-200
- video averaging, 4-199
- VIEW A, 4-200
- VIEW B, 4-201
- VIEW C, 4-201
- VIEW CAL ON OFF, 4-201
- VIEW PK QP AV, 4-202
- VIEW Δ OFF, 4-200
- VISION ENHANCE1, 4-202
- VISION ENHANCE2, 4-202
- Volts, 4-203

- W** Watts, 4-203
- WHITE DOTS, 4-203
- WHITE FILL, 4-203
- windows
 - ON, 4-52
 - ZOOM, 4-208
- WINDOWS OFF, 4-204

- X** X FINE TUNE DAC, 4-3

- Y** YTF DRIVER, 4-3, 4-204
- YTF slope and offset adjustment, 4-34
- YTF SPAN, 4-3, 4-205
- YTF TUNE COARSE, 4-3, 4-205
- YTF TUNE FINE, 4-3, 4-205
- YZ_# Spc Clear, 4-206

- Z** ZERO SPAN, 4-206
- ZONE CENTER, 4-206
- ZONE PK LEFT, 4-207
- ZONE PK RIGHT, 4-207
- ZONE SPAN, 4-208
- ZOOM, 4-208
- zooming a window, 4-208

